

Fixturing systems

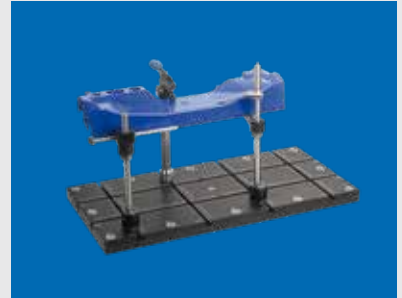

Clamping systems for measuring technology

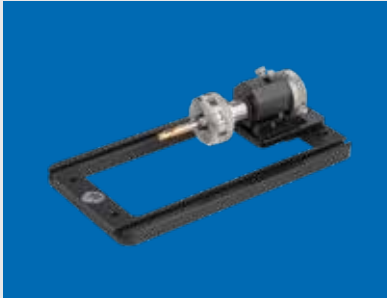
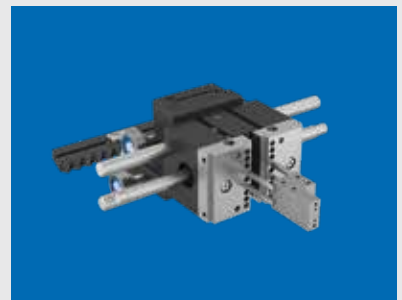
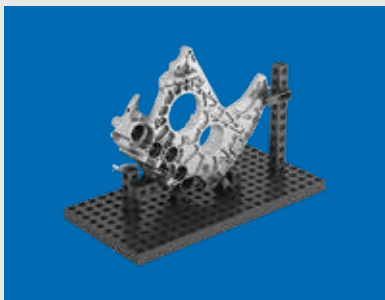

Global Source
EQUIP TO INNOVATE

dk
FIXIERSYSTEME

Good to know ...

Our range includes around 1000 products. We have clearly divided these into several thematic categories. Please consult the index or the detailed product finder which can be found at the start of each chapter.



Pictogram legend

There is a detailed pictogram legend on page 11 of this catalogue which explains all pictograms and the corresponding connections in detail. The symbols illustrate the combination possibilities of the individual basic, structural and clamping elements to produce complete clamping fixtures.



Combination possibilities for applications

In order to demonstrate the possible combinations as precisely as possible, a number of detailed application examples are included in this catalogue. These examples show which products have been combined and which products may be additionally combined.



CADENAS – Data and downloads

CADENAS is a leading software producer in the field of strategic part management, part reduction (PARTsolutions) and electronic CAD product catalogues (eCATALOG-solutions). Generated CAD models, datasheets and the possibility to make a direct enquiry for the *SWA 39*, *SPANNFIX*, *QUADERFIX* and *SCHIENENFIX* ranges are available over the CADENAS database.

<http://dk.partcommunity.com/3d-cad-models>



The digital version of our catalogue is available here: www.dk-fixiersysteme.de



You have questions about our products?

We can advise you personally and look forward to your call. We are available weekdays from 8.00 to 16.00 under +49 (0) 7121 90 97 10.





Index

Company	04
Product advantages and information	10
Connections and pictogram legend	11

Product overview

12

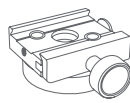

SWA39

Quick-change system for tactile and optical measuring

16

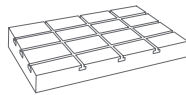

SPANNFIX PRO

Professional clamping system for tactile measuring

98

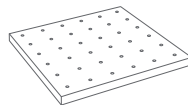

SPANNFIX ECO

Economic clamping system for tactile measuring

154

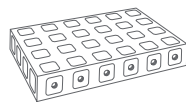

QUADERFIX

3D clamping system for tactile measuring

188

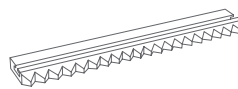

SCHIENENFIX

Clamping system for optical and multi-sensorial measuring

222

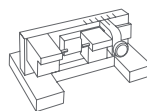

MICROFIX

Clamping solutions for micro parts

298

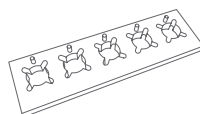

SPEZIALFIX

Customer-specific clamping fixtures

302

Part number index

312

Company

dk FIXIERSYSTEME has been developing, producing and marketing metrological clamping systems for almost 30 years. At our site in Germany, we produce modular systems of standard elements and special solutions for tactile, optical and multi-sensorial measuring equipment and now for computer tomography. Our products enjoy an excellent reputation worldwide and are valued by measuring technicians from many branches. Our credo is "listening, understanding, thinking, acting" and many of our products are the result of direct dialogue with our customers.

Our solutions help make your work easier and improve the efficiency of your metrology machines, thereby contributing to your overall success. Generally, durable modular systems are more economical than part-specific special clamping devices. The modular structure combined with the quick-change capability make dk FIXIERSYSTEME products for parts from 0.1 to 1000 mm unique worldwide in terms of function and number of components.

Innovative product development also takes place in related application sectors such as laser, marking, dispensing and handling technology. This additional know-how benefits the overall modular system and thus also the measurement technology.

The new catalogue presents an even more comprehensive range of parts and explains them coherently. We wish you every success.



Karl Holzer
Sales Management

 **Contact us directly:**
www.dk-fixiersysteme.de/request



Certificates

Our company places a high value on long-term quality and customer satisfaction, which is why dk FIXIERSYSTEME has been certified for many years.

Our company's guiding principles are customer satisfaction, technical innovation and process orientation in thinking and acting. To ensure that we deliver on these, we also have to fulfil complex processes and workflow management requirements. To achieve this we have an efficient quality management system that controls internal workflows and maintains the highest levels of product quality and customer service.

To demonstrate this to our customers, dk FIXIERSYSTEME is certified according to ISO 9001 : 2015, which is a globally recognised proof to customers, partners and suppliers for our organised quality management and ensures a continuous improvement process by our employees.

The current DIN ISO 9001:2015 certificates are available to download at any time from www.dk-fixiersysteme.de.



Our mission:

We solve our customer's clamping problems and make their tasks easier, more successful and more efficient.

Our service for you

We also develop, design and manufacture special clamping devices specifically tailored to your individual requirements and perfectly suited to your test parts and processes. These include multiple clamping, part specific fixation, control and test gauges, purely mechanical as well as partially or fully automated solutions based on pneumatic or electromechanical drives. We are happy to project fixation systems with you, which are based on our standard elements or completely detached from them.

We supplement your special requests and ideas with our experience and so create new products. We support you any time personally and with commitment by providing data, know-how and creativity. Knowledge, product information and suggestions can be obtained by telephone, email and also directly on site from our field representatives, application technicians and partners. Together we can find the best solutions. Get to know the world of dk FIXIERSYSTEME – get in touch today!



FAST REASSEMBLY LIFELONG

The basic principle of all dk fixturing systems. The compatibility of the dk programs makes the utility value perfect.



CAD data

CAD 3D models of workpieces and fixturing systems is the ideal way to plan and document your fixtures. Models of all our products are available for download in any standard CAD data format at dk.partcommunity.com/3D-cad-models.

Simply open this site directly or access it via our homepage and log in to get started. You are welcome to contact our support for 3D drafting suggestions.



Newsletter

To stay up to date with the latest news and not miss out on recent innovations, sign up to receive our free newsletter. We provide regular updates on new product developments, upcoming trade fairs and show customer-specific applications.



Newsletter subscription:

www.dk-fixiersysteme.de/newsletter

Commercial agencies



Location: dk FIXIERSYSTEME Reutlingen, Germany



Countries in which our distributors are represented



Our current distributors worldwide:

www.dk-fixiersysteme.de/representatives

CT applications

Computer tomography has long since found its way into measurement and testing technology. External and internal geometries are non-destructive, data rich, comprehensive and quick to measure. CT can be used to test the inner workings of workpieces and assembled configurations. Not only measurements can be made, but also defects such as cavities, inclusions, cracks and even the grain direction can be detected. Data from CT can be quickly reused so that it can be utilised during production as well as reverse engineering in product development. However, these high-tech possibilities have so far not been supported by a functional fixation system.

The current level of technology is reflected in the manual, unreliable, time-consuming and high-waste rough machining of PS and PUR foams. dk FIXIERSYSTEME has been developing systematic, modular components for the reproducible, precise safe clamping of test parts for CT scans for a long time. Overall, the dkXRAY range builds on the basic and structural elements used in the product ranges shown in this catalogue. The CT capability however, is only achieved with clamping elements which we presented in a separate catalogue.



Tactile and optical measuring and testing

The complete dk system consists of several differently orientated but mutually compatible ranges. In addition, we also develop customer-specific solutions. Our aim is to bring the part being tested into the optimum position and to hold it with the least possible clamping force and highest degree of repeat accuracy. This applies to both one-time part clamping and repetitive measuring tasks. The

most professional solutions are modular clamping systems. Single elements can be repeatedly used to constantly form new precise and reproducible fixture combinations. The CAD models available from dk support the planning of measuring fixtures as well as their documentation.



modular. simple. better.

Product videos

The product animations on the dk FIXIERSYSTEME Youtube channel or directly on the homepage illustrate the function and benefits of essential modular programs simply and compactly using exemplary configurations.

The *QUADERFIX* film explains how large and heavy parts can be held securely and reproducibly. In the *SCHIENENFIX* films, the different construction and clamping possibilities are demonstrated for a wide variety of products. Turned, milled, formed plate or cast products, with *SCHIENENFIX* you can optimally position and hold all manner of parts. Finally, the *SWA39* range is conveyed dynamically and very clearly in the film about the modular systems.

Take a look and see for yourself!



Access our product videos directly via the following link:

www.dk-fixiersysteme.de/startseite/technology



Product advantages of the dk system



Quick assembly

The perfectly matched module elements enable complete clamping fixtures to be easily constructed and workpieces to be quickly clamped.

Accessible measuring points

Optimum accessibility to the workpiece being measured so that, where possible, all measuring points can be reached in a single setup.

Low fixture costs

With a wide selection of standard modules, the intelligent dk concept enables the construction of simple or complex clamping fixtures without the need for custom-made parts. The constructions can be repeatedly taken apart and re-assembled in a new configuration. High wear resistance guarantees many years of repeated use. This sustainably reduces processing times for new products and saves on fixture costs.

Repeatable setup

After the first measuring process, further workpieces can always be located in the same position. Repeat measurements can be carried out in automatic mode, thereby reducing measuring time.

Reproducible fixtures

Even after complete disassembly into their individual parts, previously generated fixtures can be reproduced quickly and accurately.

Secure measuring

The parts being measured are held securely. Measurement results are not distorted and the measuring process is carried out without interruption.

Combinable systems

The scope of the modular system and the choice of configurations of the individual modules enable solutions to be produced for virtually any clamping task or measuring process. The mutual compatibility of the different dk product ranges facilitates further combinations in the future.

Table references

Height

The heights given in the tables may be absolute values or structural heights. The structural height is the amount by which the height of a fixture changes when a structural element is added.

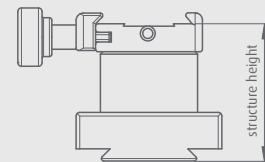

T-slots and slot keys, Designations

When sending us dimensions for T-slots or slot keys, use the following DIN designations:

DIN 650

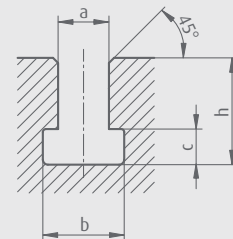

DIN 508

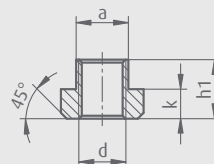

Connections and pictogram legend

The connections are used for quick and easy combinations. All pictograms in the catalogue facilitate the combination of the individual basic, structural and clamping elements into complete clamping fixtures. The relevant connection is shown for each product. For adapters, both connection interfaces are shown if these are different.

SWA 5

Quick-change adapter. A 5 mm pin/hole connection interface. Locked with a grubscrew.

SWA 8

Quick-change adapter. An 8 mm pin/hole connection interface. Locked with a grubscrew.

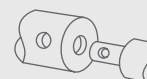

SWA 39

Quick-change adapter. Connection over a 39 mm wide dovetail slide. Tool-free locking using a knurled screw.

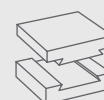

T-Nut 5

Connection over T-slot. Width 5/10 mm, height 2.5/2.5 mm. Mainly used with the *SCHIENENFIX* clamping system.

T-Nut 6

Connection over T-slot. Width 6/16 mm, height 5/5 mm. Mainly used with the *SPANNFIX* clamping system.

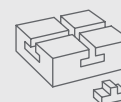

T-Nut

Connection over T-slot.

Quad

Cuboid push-fit system in 25 mm grid. Square 15 mm variant with M 5 and M 6 connection threads.

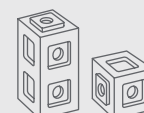

M 6

M 6 thread connection.

M 10

M 10 thread connection.

M ...

Metric thread connection.

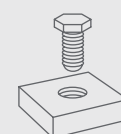

D 12

12 mm column connection.

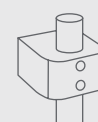

MK 2

Morse taper size 2.



**M 5
T-Nut 6**

Connecting block or adapter between different interfaces, e.g. a T-slot interface and a connection with an M 5 thread.

SWA39

Quick-change complete system for tactile and optical measuring

- » Quick-change complete system for zero-point fixture clamping
- » Basic elements for adaptation to metrology machines or inspection tables.
- » Structural elements for free positioning in 3D space
- » Clamping elements for all categories in many types and sizes
- » With stops for accurate repeat positioning of test parts
- » With scales for exact reproduction of complete fixtures
- » For tactile, optical and multi-sensorial measuring
- » Basis for computer tomography fixturing systems

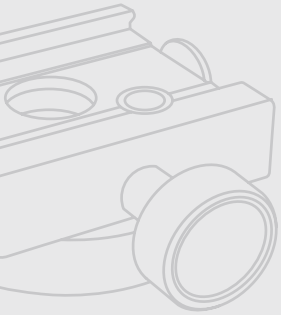

Functioning principle

Pages 20/21



Clamping elements

Pages 38-93



SPANNFIX PRO

Modular clamping elements for tactile measuring

- » Basis formed by baseplates or quick-change mounts
- » Perfect reproducibility through slot system with scale
- » Wide range of structural and clamping elements
- » Flexible clamping solutions for diverse workpiece geometries
- » Quick and easy assembly
- » For tactile metrology machines

Functioning principle

Pages 102/103



Basic elements

Pages 104-107



Vacuum systems

Pages 144-147



SWA 39 connection

Pages 148-149



SPANNFIX ECO

Modular clamping elements for tactile measuring

- » Basis formed by baseplates or quick-change mounts
- » Economical solution with grid hole system
- » Wide range of structural and clamping elements
- » Flexible clamping solutions for diverse workpiece geometries
- » Quick and easy assembly
- » For tactile metrology machines

Functioning principle

Pages 156-157



Clamping elements

Pages 172-181



Basic elements

Pages 22-27



Structural elements

Pages 28-37



Sets

Pages 94-97



Structural elements

Pages 108-129



Clamping elements

Pages 130-143



Sets

Pages 150-153



Basic elements

Pages 158-161



Structural elements

Pages 162-171



SWA 39 connection

Pages 182-183



Sets

Pages 184-187

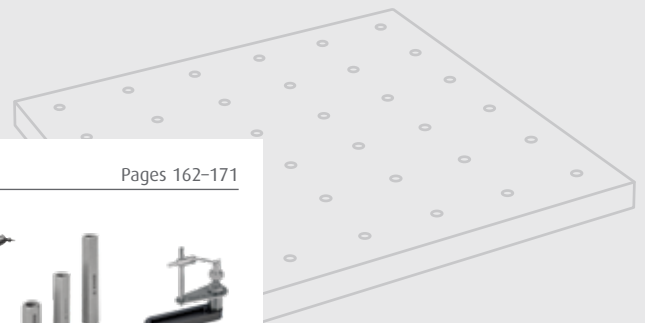
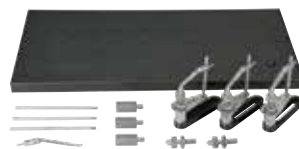

QUADERFIX

Clamping system for tactile measuring – cuboid elements

- » Modular fixture system constructed from standard Quader elements
- » Drilled through holes on a 25 mm grid
- » Compatible with the SPANNFIX product range

Functioning principle

Pages 190–191

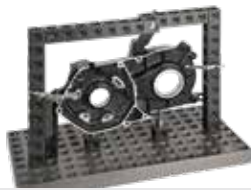

Basic elements

Pages 192–193



Clamping elements

Pages 212–217



↳ All clamping elements in the Spannfix section can also be used with the Quaderfix system.

Sets

Pages 218–221

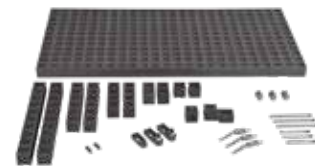

SCHIENENFIX

Clamping system for optical and multi-sensorial measuring

- » Modular clamping elements for optical or optical/tactile measuring
- » For high-precision edge measurement in reflected and transmitted light
- » Toothed rails as workpiece rests or for fastening clamping modules
- » For optical/tactile measuring machines, measuring projectors and measuring microscopes

Functioning principle

Pages 226/227

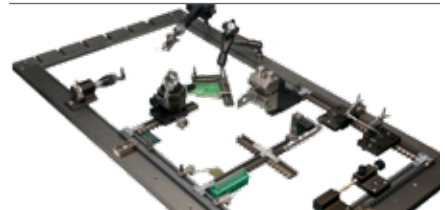

Clamping elements

Pages 242–283



MICROFIX

Clamping solutions for micro parts from 0.3 mm to 10 mm

- » Gentle fixation with adjustable clamping forces
- » For rotationally symmetrical and cuboid test parts

Micro clamping fixtures

Pages 302–303

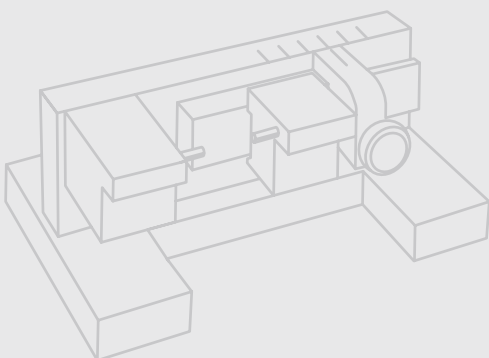

Structural elements

Pages 194-211

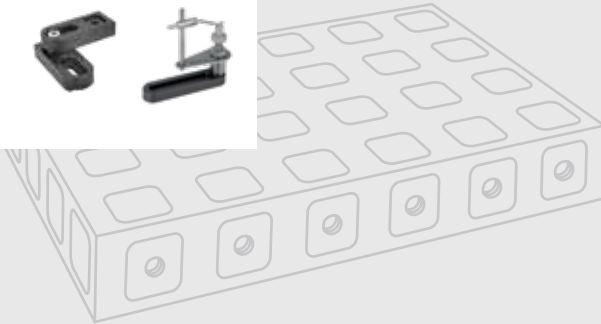

Basic elements

Pages 228-235



Structural elements

Pages 236-241

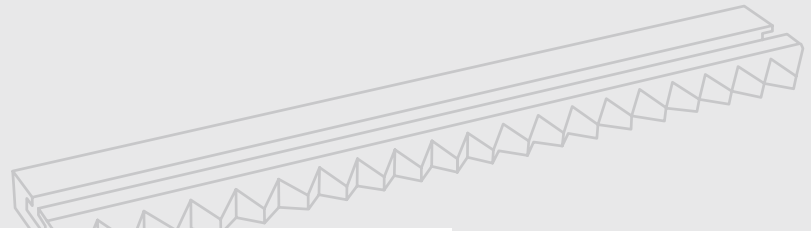

Other systems

Pages 284-287



Sets

Pages 288-297



SPEZIALFIX

Customer-specific clamping fixtures

- » We also develop, design and manufacture special clamping fixtures
- » Simple or complex single or multi-clamping systems with mechanical, pneumatic, electro-mechanical or combined clamping and handling components

Special solutions

Pages 308-315

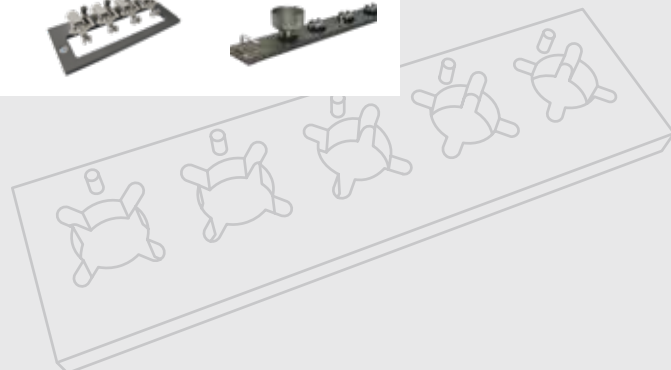
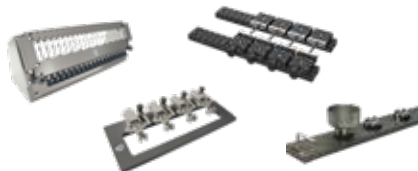

SWA39

Quick-change complete system for tactile and optical measuring

- » Quick-change complete system for zero-point fixture clamping
- » Basic elements for adaptation to metrology machines or inspection tables
- » Structural elements for free spatial positioning
- » Clamping elements for all categories in many types and sizes
- » With stops for accurate repositioning of test parts
- » With scales for exact reproduction of complete fixtures
- » For tactile, optical and multi-sensorial measuring
- » Basis for fixturing systems for computer tomography

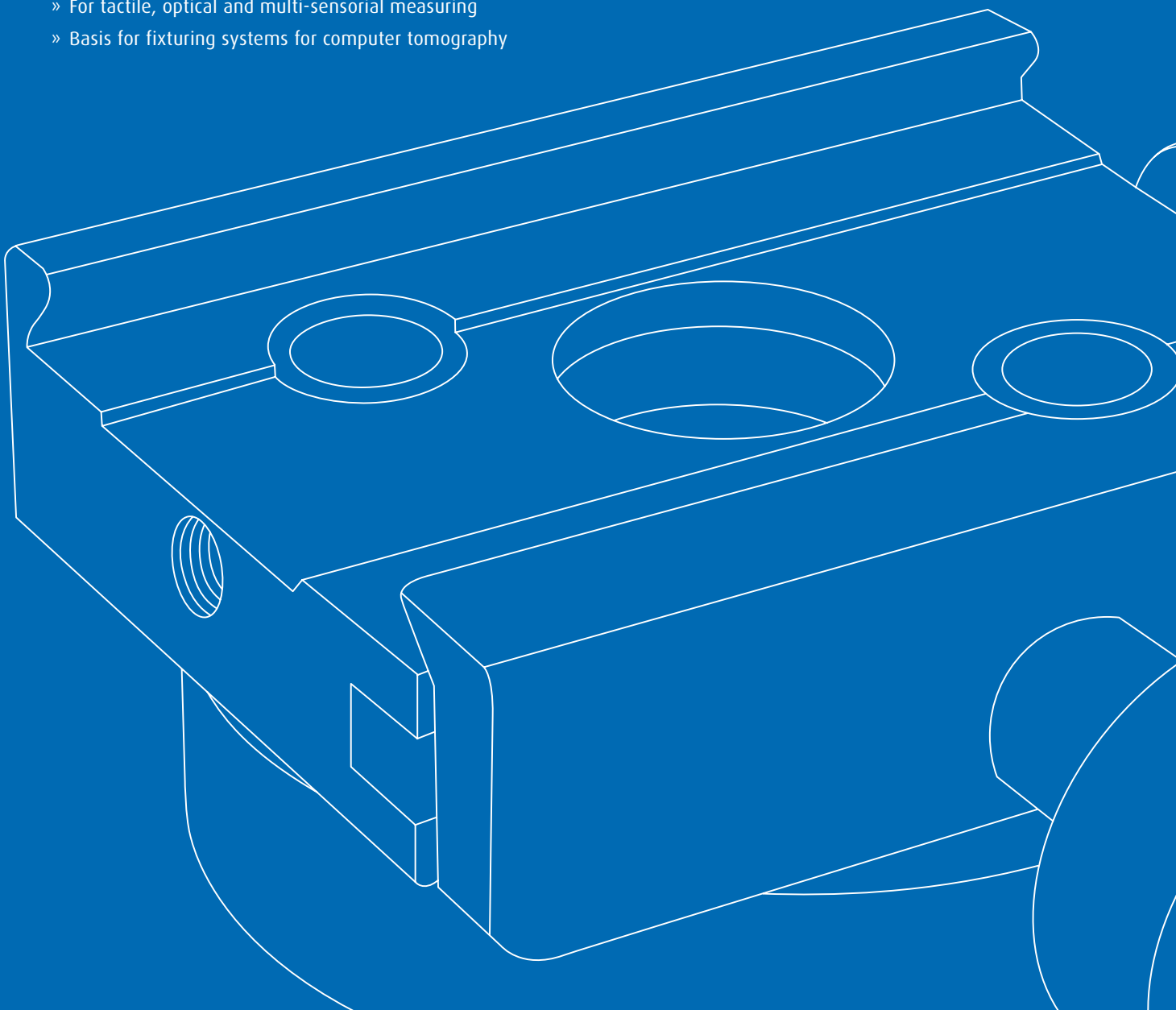

Basic elements



Quick-action clamp with fastening screw

Page 22



Quick-action clamp with extension

Page 23



Quick-action clamp for mounting in a vice

Page 23



Quick-action clamp for Alufix

Page 24



Quick-action clamp for mounting in a vice

Page 24



Quick-action clamp with magnet

Page 25



Magnetic base

Page 25



Quick-action clamp, pneumatic glide foot

Page 26



Quick-action swivel clamp on a baseplate

Page 27

Structural elements



Adapter plates for customer machining

Page 28



Adapter plates with mounting thread

Page 28



Adapter plates with mounting holes

Page 29



Adapter plates with T-slot 6

Page 29



Quick-action clamp with fixed height extension

Page 30



Quick-action clamp with adjustable height extension

Page 30



Quick-action clamp rotated 90°

Page 31



Quick-action clamp 360° rotation

Page 31



Quick-action clamp with carriage guide or cross table

Page 32



Quick-action clamp fixed 45° or 90° angle element

Page 33



Quick-action clamp, swivel unit

Page 34



Quick-action clamp, swivel unit

Page 34



Quick-action clamp, rotary and swivel unit

Page 35



Swivel unit with universal joint

Page 36



Swivel unit with ball joint

Page 36



Swivel unit with geared head

Page 37

Clamping elements
+ accessories



15 mm precision vice

Page 38 [+](#)



25 mm precision vice

Page 40 [+](#)



35 mm precision vice

Page 41 [+](#)



50 mm precision vice

Page 42 [+](#)



50 mm precision centric vice

Page 44 [+](#)



50 mm precision vice

Page 48 [+](#)



80 mm precision vice

Page 52 [+](#)



100 mm precision vice

Page 56 [+](#)



125 mm precision vice

Page 58 [+](#)



Precision mini chuck

Page 60 [+](#)



ER 16 precision collet chuck

Page 61 [+](#)

Information to dk precision three-jaw chucks
Page 62



34 mm precision three-jaw chuck

Page 64 [+](#)



50 mm precision three-jaw chuck

Page 66 [+](#)



65 mm precision three-jaw chuck

Page 68 [+](#)



100 mm precision three-jaw chuck

Page 70 [+](#)



160 mm precision three-jaw chuck

Page 72 [+](#)



Rotary table with precision three-jaw chuck

Page 74 [+](#)



NADELFIX function and advantages

Page 76 [+](#)



NADELFIX 2.5

Page 76 [+](#)



NADELFIX 5 Mini

Page 77 [+](#)



NADELFIX 5 Midi

Page 77 [+](#)



NADELFIX 5 Maxi

Page 78 [+](#)



Small-parts clamp, smooth

Page 80 [+](#)



Small-parts clamp, jaw stepped one side

Page 81 [+](#)



Small-parts clamp with horizontal prism

Page 82 [+](#)



Small-parts clamp with top-face prism

Page 82 [+](#)



Small-parts clamp for internal clamping

Page 83 [+](#)



Stop unit for small-parts clamps

Page 84 [+](#)



Permanent magnet clamping mounts

Page 85 [+](#)



Magnetic clamping mounts, switchable

Page 85 [+](#)



Permanent magnet V-block

Page 86 [+](#)



Magnetic V-block, switchable

Page 86 [+](#)



Small V-block with spring finger

Page 87 [+](#)



V-block

Page 88 [+](#)



V-blocks pairs, adjustable on SWA 39 rail

Page 90 [+](#)



Pneumatic glide foot Airbase

Page 92 [+](#)



Vacuum clamping plates - round

Page 92 [+](#)



Vacuum clamping plate - square

Page 93 [+](#)

Clamping sets



Set "A"

Page 94

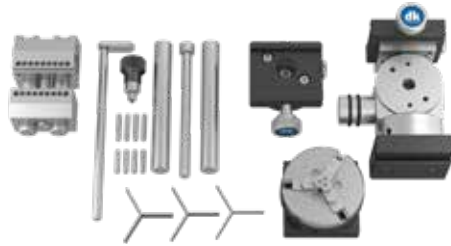

Set "B"

Page 95

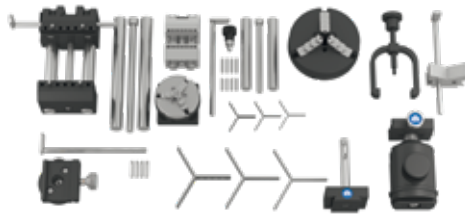

Set "C"

Page 96

Quick-change adaptation system for reproducible zero points

Unique, high-quality and reliable – dk SWA 39 modular system for fixating technology:

- A huge selection of basic, structural, adjustment and clamping elements with standardised interfaces
- Individual elements and entire fixtures can be changed quickly
- Positive fixating with a high reference accuracy as a base for zero-point fixture clamping
- Highest quality for maximum service life

Basic elements

- 1 Baseplate with tapped holes (page 158)



Other baseplates
(Pages 104–105)



- 2 Quick-action clamp with fastening screw (page 22)



Other quick-action clamps
(from page 23)



Structural elements

- 3 Quick-action clamp with height extension (page 30)



Other versions and adaptations
(pages 22–37)



- 4 Quick-action clamp angle element (page 33)





Clamping elements

- 5 Rotary table with precision three-jaw chuck (page 74)



Other clamping elements and accessories (pages 38-91)



FAST REASSEMBLY LIFELONG

The basic principle of all dk fixturing systems. The compatibility of the dk programs makes the utility value perfect.

The result:

- quick, simple, workpiece and process-oriented positioning and clamping
- rapid conversion to new workpieces and processes
- possibility of workpiece setups outside of the machine during measuring process
- disassemble and reassemble entirely new or exactly the same fixtures countless times
- an alternative to classic, inflexible, single-use fixture constructions

Quick-action clamp with fastening screw

Description

SWA 39 quick-action base clamp for mounting all structural, adjustment and clamping elements of the SWA 39 system. For direct fastening in tapped holes or T-slots. Mounted on a 12 mm high intermediate plate.

Material

Hard-coated aluminium/stainless steel.

Supplied with

Fasteners



Order No.	Fastening screw	Height
285204	M4	23.5
285205	M5	23.5
285206	M6	23.5
285208	M8	23.5
285210	M10	23.5
285212	M12	23.5
285300	Set for T-slot 6	23.5

SWA 39
M ...

Application example



Quick-action clamp with extension

Description

SWA 39 quick-action clamp for direct fastening in tapped holes.
Mounted on 50/100 mm extensions.

Material

Hard-coated aluminium.

Supplied with

Fastening screw.



Order No.	Fastening screw	Height
330506	M6	61.5
330508	M8	61.5
330510	M10	61.5
330512	M12	61.5
330606	M6	111.5
330608	M8	111.5
330610	M10	111.5
330612	M12	111.5

SWA 39
M ...

Quick-action clamp for special mounts

Description

SWA 39 quick-action clamp for screwing onto special mounts.

Material

Hard-coated aluminium.

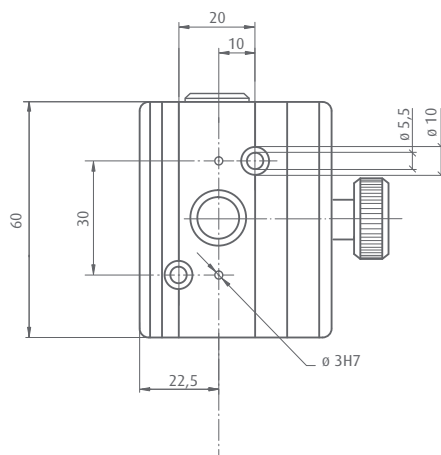

Order No.	Height
273300	11.5

SWA 39
M ...

Quick-action clamp for Alufix

Description

SWA 39 quick-action clamp for mounting on Alufix 16 or 25 system baseplates.

Material

Hard-coated aluminium.



Application example



Order No.	System	Length	Width	Height
274700	16	60	78	32
274710	25	66	78	32
274720	25/grid 50	116	78	32

Quick-action clamp for mounting in a vice

Description

SWA 39 quick-action clamp for mounting in any standard vice (min. jaw width 40 mm).

Material

Hard-coated aluminium/steel.



Order No.	Height
330800	52

SWA 39

Quick-action clamp with magnet

Description

SWA 39 quick-action clamp on permanent magnet with On-Off switch for mounting on steel plates. Vertical lift-off force 1000 N.

Material

Hard-coated aluminium/steel.



Order No.	Length	Width	Height	Lift-off force
313800	68	76	71.5	1000 N

SWA 39

Magnetic base

Description

Permanent magnet with On-Off switch and M 8 or M 10 tapped hole. Vertical lift-off force 800 N or 1000 N.

Material

Steel.

Application example



Order No.	Thread	Length	Width	Height	Lift-off force
251500	M10	68	53	60	1000 N
251400	M8	36	53	60	800 N

M 10

Quick-action clamp on a pneumatic glide foot

Description

Basic attachment for SWA 39 modular elements on smooth surfaces. Easy glide on an air cushion. Fix in place by vacuum. Connection modules with SWA 39 interface. Maximum load ca. 15 kg. Operating pressure 4.5 to 6 bar. Operate only with dry, oil-free air.

With port for vacuum generation in other elements that may be connected.
See pages 92 to 93.



Order No.	Length	Width	Height	Version	Weight
270200	300	200	56	With ext. vacuum port	3.3

SWA 39

Application example

SWA 39 pneumatic glide foot:

The pneumatic glide foot is the ideal basic attachment for smooth surfaces that have no mounting holes. The pneumatic foot glides on an air cushion and is secured by a vacuum. A clamping fixture can therefore be manoeuvred into, and locked in any point on the inspection table – no screws required. The SWA 39 interface on the products top face is ideal for quick, reliable and straightforward mounting of any module to swivel and fixate parts to be measured or tested.



Quick-action rotate and swivel clamp on a baseplate

Description

SWA 39 quick-action clamp mounted on baseplate.
With 90° swivel element.

Material

Hard-coated aluminium/stainless steel.



Application example

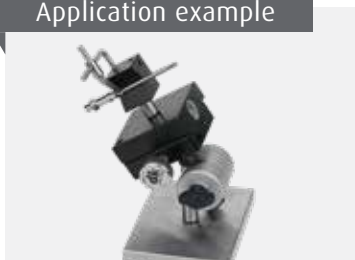

Order No.	Length	Width	Height*	Weight
270560	100	80	82	1.1

SWA 39

* Minimum height with horizontal quick-action clamp

Application example

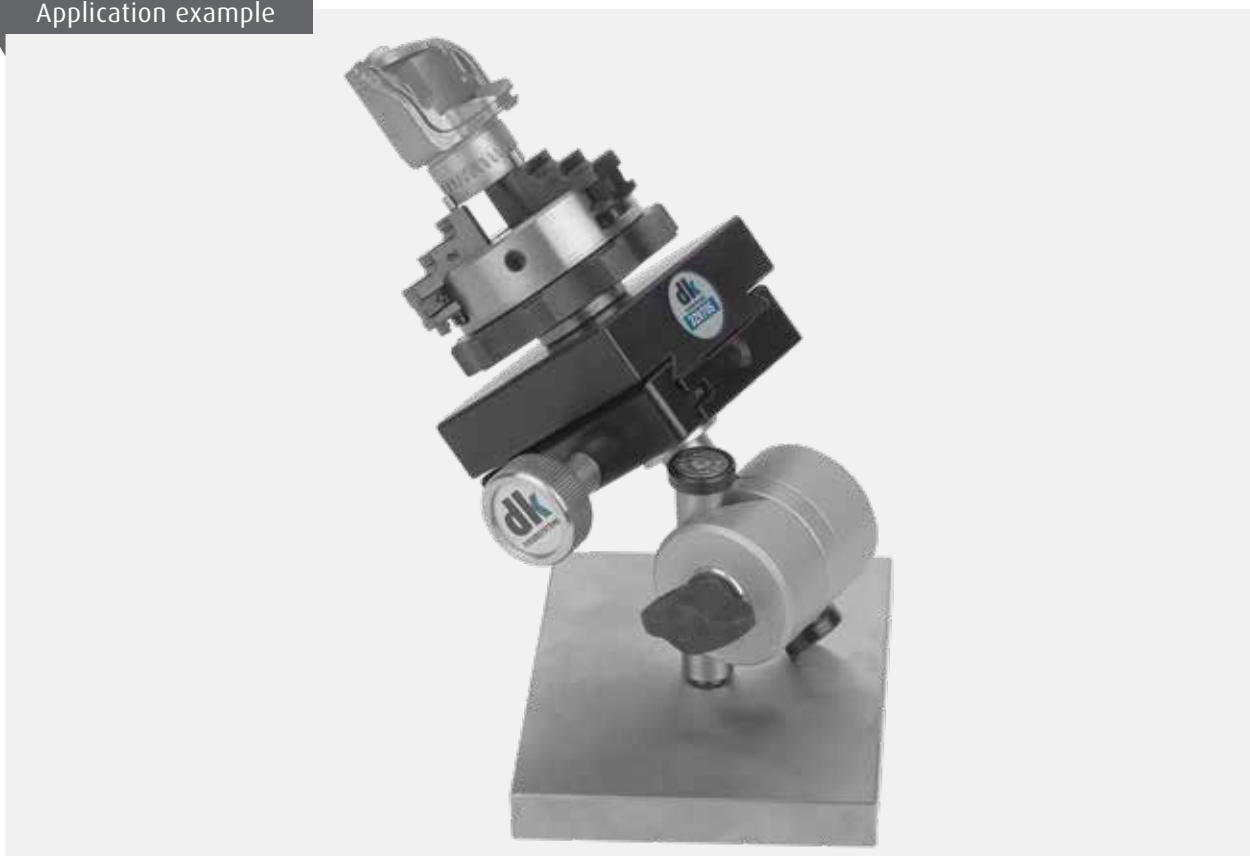

Adapter plates for customer machining

Description

Baseplate with SWA 39 quick-change adapter. With standard or cross interface. The adapter with the standard interface can be installed in two positions on the quick-change mount, the cross interface four positions. Plate for machining by the user as required.

Material

Hard-coated aluminium.



Order No.	Version	Length	Width	Height	Fig.
273000	Standard interface	60	60	20	1
314500	Cross interface	60	60	20	

SWA 39

Adapter plates with central tapped hole

Description

Baseplate with SWA 39 quick-change adapter and central tapped hole.

Material

Hard-coated aluminium.



Application example



Order No.	Version	Length	Width	Height
273006	M6	60	60	20
273008	M8	60	60	20
273010	M 10	60	60	20
273012	M12	60	60	20

M ...
SWA 39

Adapter plates with tapped holes

Description

Baseplates with tapped holes. One central hole or four holes arranged in a square.

Material

Hard-coated aluminium.

Supplied with

4x M4 fastening screws or

1x M6 fastening screw.

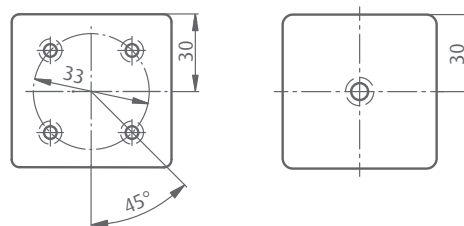

Order No.	Version	Length	Width	Height	Fig.
397020	4x M4 holes with standard interface	60	60	20	1
397030	4x M4 holes with cross interface	60	60	20	
397040	1x M6 hole with standard interface	60	60	20	

M ...
SWA 39

Adapter plates with T-slot 6

Description

Baseplate with T-slot 6 for mounting diverse modules, e.g. structural elements from the *SPANNFIX* range. With SWA 39 quick-change adapter for mounting on SWA 39 basic elements.

Material

Hard-coated aluminium.

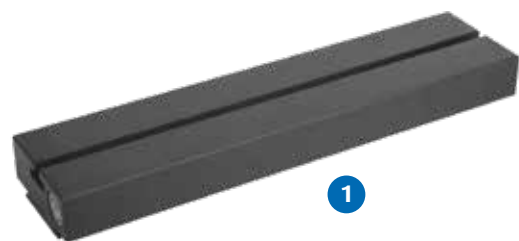

Order No.	Length	Width	Height	Fig.
305000	140	60	24	
305100	250	60	24	1
305110	500	60	24	

T-Nut 6
SWA 39

Quick-action clamp with fixed height extension

Description

Extension modules with SWA 39 quick-change adapter.

Material

Hard-coated aluminium.

Application example



Order No.	Length	Width	Height
273600	60	80	61.5
273700	60	80	111.5

SWA 39

Quick-action clamp with adjustable height extension (fine adjustment)

Description

Extension modules, with threaded spindle for infinite fine adjustment, knurled screw and lock.

Mounted on an SWA 39 quick-change adapter.

Material

Hard-coated aluminium.



Order No.	Length	Width	Height
273800	60	80	60-80
273900	60	80	80-120

SWA 39

Quick-action clamp rotated 90°

Description

SWA 39 quick-action clamp for the mounting modules offset at 90°. Mounted on an SWA 39 quick-change adapter.

Material

Hard-coated aluminium.



Order No.	Length	Width	Height
314400	60	80	31.5

SWA 39

Quick-action clamp 360° rotation

Description

Quick-action clamp, rotates freely or indexed at 90°. Indexing function can be removed. Angular adjustment with a scale accurate to 2°. Knurled screw lock. Alternatively with fine adjustment. Mounted on an SWA 39 quick-change adapter.

Material

Hard-coated aluminium, stainless steel shaft.



Order No.	Rotation	Function	Length	Width	Height	Fig.
283450	360°/indexed every 90°	manual	60	80	52	1
283460	360°/ fine adjustment	Gear drive	60	90	72	2

SWA 39

Quick-action clamp with slide or cross table

Description

SWA 39 quick-action clamp with infinite, high-precision X or X/Y adjustment. Mounted on an SWA 39 quick-change adapter.

Material

Hard-coated aluminium.



Order No.	Function	Travel	Length	Width	Height	Fig.
314460	Cross table X/Y	25	80	80	78	1
314450	Slide X	25	80	80	55	2

SWA 39

Application example



Quick-action clamp fixed 45° or 90° angle element

Description

Fixed 45° or 90° angle element for mounting positioning and clamping elements, with an SWA 39 quick-change clamp. With SWA 39 quick-change adapter.

Material

Hard-coated aluminium.



Order No.	Angle	Length	Width	Height	Fig.
283300	90°	60	90	60	1
283320	45°	60	90	70	2

SWA 39

Application example



Quick-action clamp on a pivot unit (quick adjustment)

Description

SWA 39 quick-action clamp, infinite or 45° indexed pivot through $\pm 90^\circ$. Scale with 5° divisions. Mounted on an SWA 39 quick-change adapter.

Material

Hard-coated aluminium.

Supplied with

Detachable stop for 0°, 45° and 90°.



Order No.	Pivot range	Length	Width	Height
314000	+90°/-90°	60	80	87

SWA 39

Quick-action clamp on a pivot unit (fine adjustment)

Description

SWA 39 quick-action clamp, infinite pivot through $+90^\circ/-55^\circ$. A worm gear drives the pivot. Scale for angular adjustment accurate to 2°. Mounted on an SWA 39 quick-change adapter.

Material

Hard-coated aluminium.



Order No.	Swivel range	Length	Width	Height
314010	+90°/-55°	85	80	97
314015	clamping set for pivot unit			

SWA 39

Quick-action rotary and pivot unit clamp

Description

SWA 39 quick-action pivot and rotating clamp Pivot range $+90^\circ / -55^\circ$. A worm gear drives the pivot. Infinite rotation through 360° or indexed every 90° . Indexing function can be removed. Angular adjustment with a scale accurate to 2° . Knurled screw lock. Mounted on an SWA 39 quick-change adapter.

Material

Hard-coated aluminium, stainless steel shaft. Steel worm.



Order No.	Rotation	Pivot	Length	Width	Height	Fig.
314020	360° /indexed every 90°	$+90^\circ/-55^\circ$	85	80	114	1
314030	360° /fine worm drive	$+90^\circ/-55^\circ$	85	80	114	2
314015	clamping set for pivot unit					

SWA 39

Application example



Swivel unit with universal joint

Description

SWA 39 quick-action clamp for quick and flexible spatial clamping of parts. Swivels up to 90°. Swivel element can be locked with a clamping screw. Mounted on an SWA 39 quick-change adapter.

Material

Hard-coated aluminium, stainless steel shaft.



Order No.	Length	Width	Height*	Weight
270570	60	60	90	0.52

* Minimum height with horizontal quick-action clamp

SWA 39

Swivel unit with ball joint

Description

Swivel unit for quick and flexible spatial clamping of parts. Rotates through 360°. Swivels up to 90°. Mounted on an SWA 39 quick-change adapter.

Material

Hard-coated aluminium.

Application example



Order No.	Length	Width	Height	Weight
270500	70	90	120	0.86

SWA 39

Swivel unit with geared head

Description

3D geared head for quick and flexible spatial positioning of parts. Both the entire swivel unit and the upper quick-action clamp can be rotated through 360°. Two separate goniometers and a pivot unit enable swivelling up to 90°. Mounted on an SWA 39 quick-change adapter. Scales in all axis enable for reproducible clamping without any problem.

Material

Body hard-coated aluminium.
Guides and drive brass/steel.



Order No.	Length	Width	Height*	Weight
270650	110	110	126	1.3

SWA 39

Application example



15 mm precision vice

Description

Miniature vice with prism jaws. With SWA 39, SWA 5 or M 4 connection. Brass or stainless steel versions available. M 4 hole centre distance is 42 mm.

Supplied with

Stainless steel (270921) and plastic exchange jaws.



SWA 39

SWA 5

M ...

Order No.	Version	Jaw width	Clamping width	Total height	Material	Fig.
270910	SWA 39	15	14.5	61	Brass	1
270915	SWA 39	15	14.5	61	Stainless steel	1
270900	SWA 5	15	14.5	27	Brass	2
270905	SWA 5	15	14.5	27	Stainless steel	2
270920	2x M4	15	14.5	15	Brass	3
270925	2x M4	15	14.5	15	Stainless steel	3

Accessories

+ Form jaw with prism

Order No.	Material	Jaw width	Supplied with	Description
270921	Stainless steel	15	1 set jaws one smooth and one prism jaw	With vertical and horizontal prisms



+ Stepped jaw

Order No.	Material	Jaw width	Contents	Description
270922	Stainless steel	15	1 jaw	Step height 1.5 mm Step depth 1.0 mm



Application examples



25 mm precision vice

Description

Miniature vice with prism jaws. With SWA 39, SWA 5 or M 4 connection. Aluminium and stainless steel versions available. M 4 hole centre distance is 62,5 mm.

Supplied with

Stainless steel (270971) and plastic exchange jaws.

Application example



SWA 39

SWA 5

M ...

Order No.	Version	Jaw width	Clamping width	Total height	Material	Fig.
270960	SWA 39	25	24.5	53	Aluminium	1
270965	SWA 39	25	24.5	53	Stainless steel	1
270950	SWA 5	25	24.5	38	Aluminium	2
270955	SWA 5	25	24.5	38	Stainless steel	2
270970	2x M4	25	24.5	25	Aluminium	3
270975	2x M4	25	24.5	25	Stainless steel	3

Accessories

+ Form jaw with prism

Order No.	Material	Jaw width	Supplied with	Description
270971	Stainless steel	25	1 set jaws one smooth and one prism jaw	With vertical and horizontal prisms



+ Stepped jaw

Order No.	Material	Jaw width	Contents	Description
270972	Stainless steel	25	1 jaw	Step height 1.8 mm Step depth 1.3 mm



+ Stop

Order No.	Material	Length	Adjustment range
318250	Stainless steel/aluminium	75	50



35 mm precision vice

Description

Miniature vice with prism jaws. With SWA 39 or M 5 connection. Aluminium and stainless steel versions available. Jaws with Ø2 mm holes for clamping pins. M5 hole centre distance is 83 mm.

Supplied with

Stainless steel (270861) and plastic exchange jaws and 4x Ø2 mm pins.

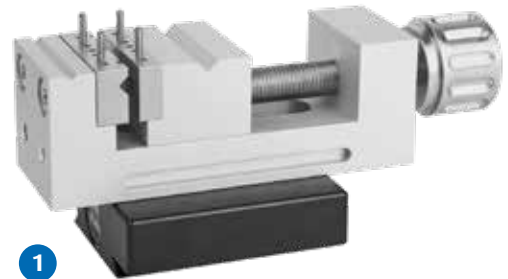

1



2

Application example



SWA 39

M ...

Order No.	Version	Jaw width	Clamping width	Total height	Material	Fig.
270850	SWA 39	35	34.5	55	Aluminium	1
270855	SWA 39	35	34.5	55	Stainless steel	1
270860	2x M5 / 4x M4	35	34.5	35	Aluminium	2
270865	2x M5 / 4x M4	35	34.5	35	Stainless steel	2

Accessories

+ Form jaw with prism

Order No.	Material	Jaw width	Supplied with	Description
270861	Stainless steel	35	1 set jaws one smooth and one prism jaw	With vertical and horizontal prisms



+ Stepped jaw

Order No.	Material	Jaw width	Contents	Description
270862	Stainless steel	35	1 jaw	Step height 2.0 mm Step depth 1.5 mm



+ Stop

Order No.	Material	Length	Adjustment range
318250	Stainless steel/ aluminium	75	50



50 mm pull down precision vice

Description

Positive down force vice with quick adjustment and adjustable stop. SWA 39 quick-change adapter integrated into the vice base. With stepped jaws and Ø4 mm holes for clamping pins. Optional stainless steel exchange jaws.

Material

Surface hardened steel.

Supplied with

Adjustable stop (318110), 4 pins for pin clamping and operating tools.



Order No.	Jaw width	Clamping width	Weight
270700	50	80	1.46

SWA 39

Accessories

+ Smooth jaws

Order No.	Material	Jaw width	Supplied with	Description
271200	Stainless steel	50	1 set exchangeable jaws and fastening screws	-



+ Form jaws with small prisms

Order No.	Material	Jaw width	Supplied with	Clamping diameter
271500	Stainless steel	50	1 set jaws one smooth and one prism jaw	recommended from 2.5 mm



+ Form jaws with large prisms

Order No.	Material	Jaw width	Supplied with	Clamping diameter
271900	Stainless steel	50	1 set jaws one smooth and one prism jaw	recommended from 6 mm



+ Clamping pins, stepped

Order No.	Contact face	Length	Contents	Description
282300	straight	24 x Ø4	Set of 4	for raised part positioning
282310	straight	35 x Ø4	Set of 4	
326500	120° prism	25 x Ø4	2 prism pairs	



+ Support discs with pins

Order No.	Version	Disc size	Contents	Description
338300	Adjustable	Ø16 x 9	Set of 4	For raised part positioning



+ Universal stop

Order No.	Material	Supplied with
277510	Steel	2 exchangeable stop points



+ Stop for vices

Order No.	Material	Length	Overhang	Description
318100	Steel	50	20	-
318200	Steel	50	40	
318110	Steel	150	20	
318210	Steel	150	40	



Application example



50 mm precision centric vice

Description

Centric vice with stepped jaws and adaptation options for a range of accessory elements. Pin holes for raised positioning of parts for access from all sides. Version with an SWA 39 quick-change adapter which can be mounted offset by 90°.

Material

Surface hardened steel and hard-coated aluminium.

Supplied with

4 pins, adjustable stop and operating tools.



Order No.	Jaw width	Version	Clamping width
282150	50	SWA 39 (removable)	120 mm

SWA 39

Application example



Accessories

+ Smooth jaws

Order No.	Material	Jaw width	Contents	Description
282400	Stainless steel	50	1 set	-



+ Form jaws with prisms

Order No.	Material	Jaw width	Supplied with	Clamping diameter
282700	Stainless steel	50	1 set jaws one smooth and one prism jaw	recommended from 2 mm



+ Form jaws with prisms for end-face clamping

Order No.	Material	Jaw width	Contents	Clamping diameter
306610	Stainless steel	50	1 set	15-50 mm



+ Smooth jaws for small parts

Order No.	Material	Jaw width	Contents	Description
282410	Stainless steel	50	1 jaw	For clamping small parts



Application example



Accessories

+ Pin jaws

Order No.	Material	Jaw width	Contents	Description
282430	Stainless steel	50	1 set	for shorter clamping widths



+ Two-point contact prism jaws

Order No.	Material	Jaw width	Supplied with	Clamping diameter
306900	Hard-coated aluminium	5	1 prism jaw and 1 straight jaw	3–20 mm



+ Three-point contact prism jaws

Order No.	Material	Jaw width	Supplied with	Clamping diameter
306800	Hard-coated aluminium	5+16	1 double prism jaw and 1 straight jaw	Recommended up to 30 mm



+ Clamping pins, stepped

Order No.	Contact face	Length	Contents
282300	Straight	24 x Ø4	Set of 4 for raised part positioning 2 prism pairs
282310	Straight	35 x Ø4	
326500	120° prism	25 x Ø4	



+ Support discs with pins

Order No.	Version	Disc size	Contents	Description
338300	adjustable	Ø16 x 9	Set of 4	for raised part positioning



+ Universal stop

Order No.	Material	Supplied with
277510	Steel	2 exchangeable stop points



+ Stop for vices

Order No.	Material	Length	Overhang	Description
318100	Steel	50	20	-
318200	Steel	50	40	
318110	Steel	150	20	
318210	Steel	150	40	



Application example

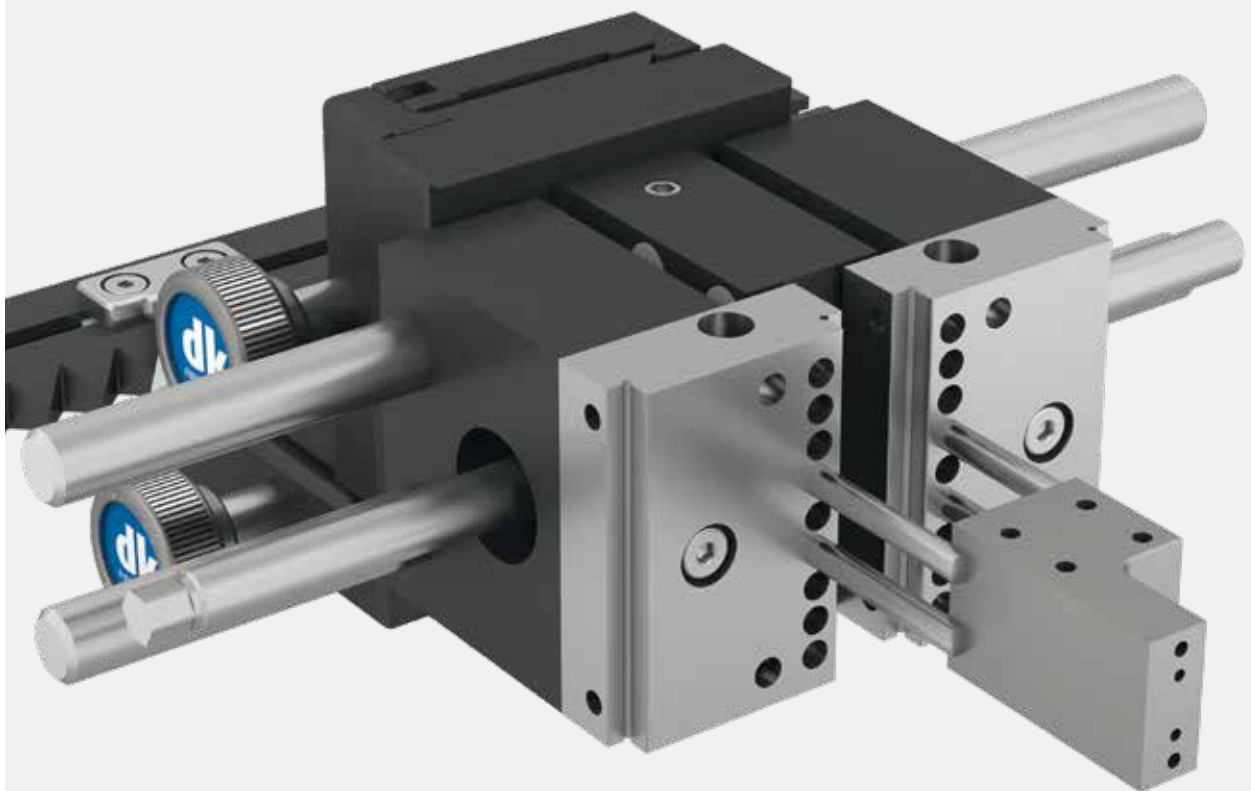

50 mm precision vice

Description

Vice with exchangeable clamping width extension guide shafts. With stepped jaws and Ø4 mm holes for clamping pins.
 Versions with and without SWA 39 quick-change adapter and with and without accessories are available. The versions without quick-change adapter have 4 contact faces at right angles to each other.

Material

Surface hardened steel.

Supplied with

Versions with accessories include an adjustable stop (318110), a set of shafts for extending the clamping width to 75 mm, 4 pins and a magnetic push-in knurled knob (282101).

↳ A quick-change adapter (397020) can be retrofitted on versions without SWA 39, see page 29.



1



2

Vice with accessories.

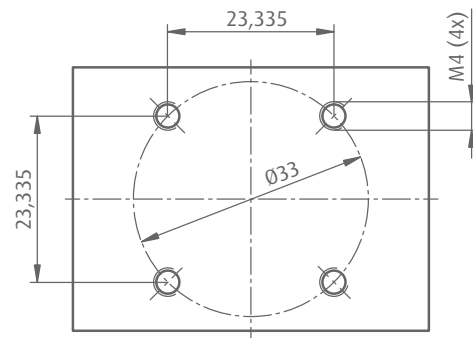
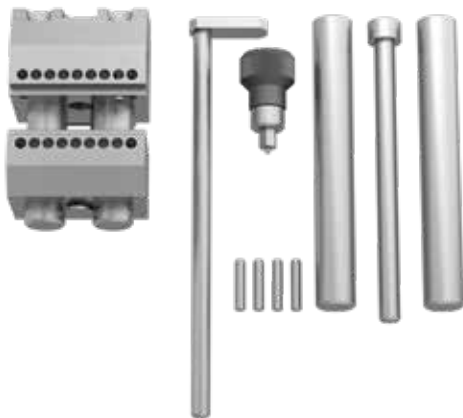

Order No.	Jaw width	Version	Accessories	Clamping width	Weight	Fig.
282100	50	SWA 39	yes	35 / 75*	1.05	1
282105	50	SWA 39	no	35*	0.87	
282110	50	4 contact faces	yes	35 / 75*	1.01	
282115	50	4 contact faces	no	35*	0.82	2

* Can be extended up to 150 mm with extra shaft sets.

Accessories

+ Shaft set for clamping range extension

Order No.	Material	Jaw width	Supplied with	Description
282200	Surface hardened steel	-	2 sets of 2 shafts with a threaded spindle	Clamping width extension to 100 mm or 150 mm



+ Smooth jaws

Order No.	Material	Jaw width	Contents	Description
282400	Stainless steel	50	1 set	-



+ Form jaws with prism

Order No.	Material	Jaw width	Supplied with	Clamping diameter
282700	Stainless steel	50	1 set jaws one smooth and one prism jaw	recommended from 2 mm



+ Form jaws with prisms for end-face clamping

Order No.	Material	Jaw width	Contents	Clamping diameter
306610	Stainless steel	50	1 set	15-50 mm



+ Smooth jaws for small parts

Order No.	Material	Jaw width	Contents	Description
282410	Stainless steel	50	1 jaw	For clamping small parts in the stepped jaws



Application example



Accessories

+ Pin jaws

Order No.	Material	Jaw width	Contents	Description
282430	Stainless steel	50	1 set	For shorter clamping widths



+ Two-point contact prism jaws

Order No.	Material	Jaw width	Supplied with	Clamping diameter
306900	Hard-coated aluminium	5	1 prism jaw and 1 straight jaw	3–20 mm



+ Three-point contact prism jaws

Order No.	Material	Jaw width	Supplied with	Clamping diameter
306800	Hard-coated aluminium	5+16	1 double prism jaw and 1 straight jaw	recommended up to 30 mm



+ Clamping pins, stepped

Order No.	Contact face	Length	Contents	Description
282300	Straight	24 x Ø4	Set of 4	for raised part positioning
282310	Straight	35 x Ø4	Set of 4	
326500	120° prism	25 x Ø4	2 prism pairs	



+ Support discs with pins

Order No.	Version	Disc size	Contents	Description
338300	Adjustable	Ø16 x 9	Set of 4	for raised part positioning



+ Universal stop

Order No.	Material	Supplied with
277510	Steel	2 exchangeable stop points



+ Stop for vices

Order No.	Material	Length	Overhang	Description
318100	Steel	50	20	
318200	Steel	50	40	
318110	Steel	150	20	
318210	Steel	150	40	



+ Knurled knobs

Order No.	Version
282101	magnetic
282102	magnetic with adjustable torque, ca. 0.1–0.3 Nm



Application examples



External clamping with pins for additional elevation for optimum accessibility to all faces.



Internal clamping with pins for additional elevation.



Precise repeatable clamping with adjustable stop.

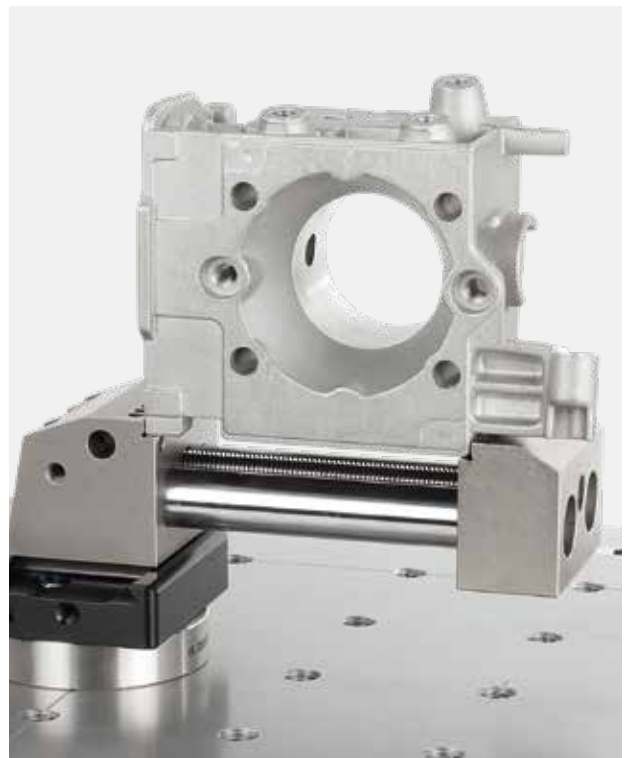

Clamping width extended to 75 mm, 100 mm or 150 mm using accessories.

80 mm precision vice

Description

Vice with exchangeable clamping width extension guide shafts. SWA 39 quick-change adapter integrated in the vice base. For flexible fastening of the vice, version 308300 includes two additional SWA 39 quick-change adapters offset through 90°. With stepped jaws and Ø5 mm holes for clamping pins.

Material

Hard-coated aluminium with surface hardened steel jaws.

Supplied with

1 adjustable stop (318110), an extra set of shafts for extending the clamping width up to 130 mm, 4 clamping pins and operating tools.



Order No.	Jaw width	Clamping width	Fastening	Weight	Fig.
308200	80	80 / 130*	on the base	1.65	1
308300	80	80 / 130*	on the base or on two sides offset 90° to each other	1.7	

SWA 39

* Can be extended up to 200 mm with extra shaft sets.

Positioning options for 308300 with an SWA 39 interface on 3 different sides:

Application example



a) Standard



b) Sideways



c) Upright

+ Shaft set for clamping range extension

Order No.	Material	Jaw width	Supplied with	Description
307700	Surface hardened steel	-	1 set of 2 guide shafts and 1 threaded spindle	for clamping range extension up to 200 mm



+ Smooth jaws

Order No.	Material	Jaw width	Contents	Description
307000	Stainless steel	80	1 set	-



+ Form jaws with small prisms

Order No.	Material	Jaw width	Supplied with	Clamping diameter
307300	Stainless steel	80	1 set jaws one smooth and one prism jaw	recommended vertical and horizontal from 5 mm



+ Form jaws with prisms for end-face clamping

Order No.	Material	Jaw width	Contents	Clamping diameter
307601	Stainless steel	80	1 set	recommended from 20 to 85 mm



+ Two-point contact prism jaws

Order No.	Material	Jaw width	Supplied with	Clamping diameter
306915	Hard-coated aluminium	7.5	1 prism jaw and 1 straight jaw	8-50 mm



+ Three-point contact prism jaws

Order No.	Material	Jaw width	Supplied with	Clamping diameter
306810	Hard-coated aluminium	5+16	1 double prism jaw and 1 straight jaw	2-50 mm



+ Jaws with 2 rows of pins holes

Order No.	Material	Jaw width	Contents	Description
307610	Steel	80	1 set	for Ø5 mm pins



Accessories

+ Universal stop

Order No.	Material	Supplied with	Description
277510	Steel	With 2 exchangeable stop points	



+ Clamping pins, stepped

Order No.	Contact face	Length	Contents	Description
307800	Straight	26 x 05	Set of 4	for raised part
307810	Straight	36 x 05	Set of 4	positioning
326600	120° prism	30 x 05	2 prism pairs	
326610	120° prism	35 x 05	2 prism pairs	



+ Stop for vices

Order No.	Material	Length	Overhang	Description
318100	Steel	50	20	
318200	Steel	50	40	
318110	Steel	150	20	
318210	Steel	150	40	



Application example

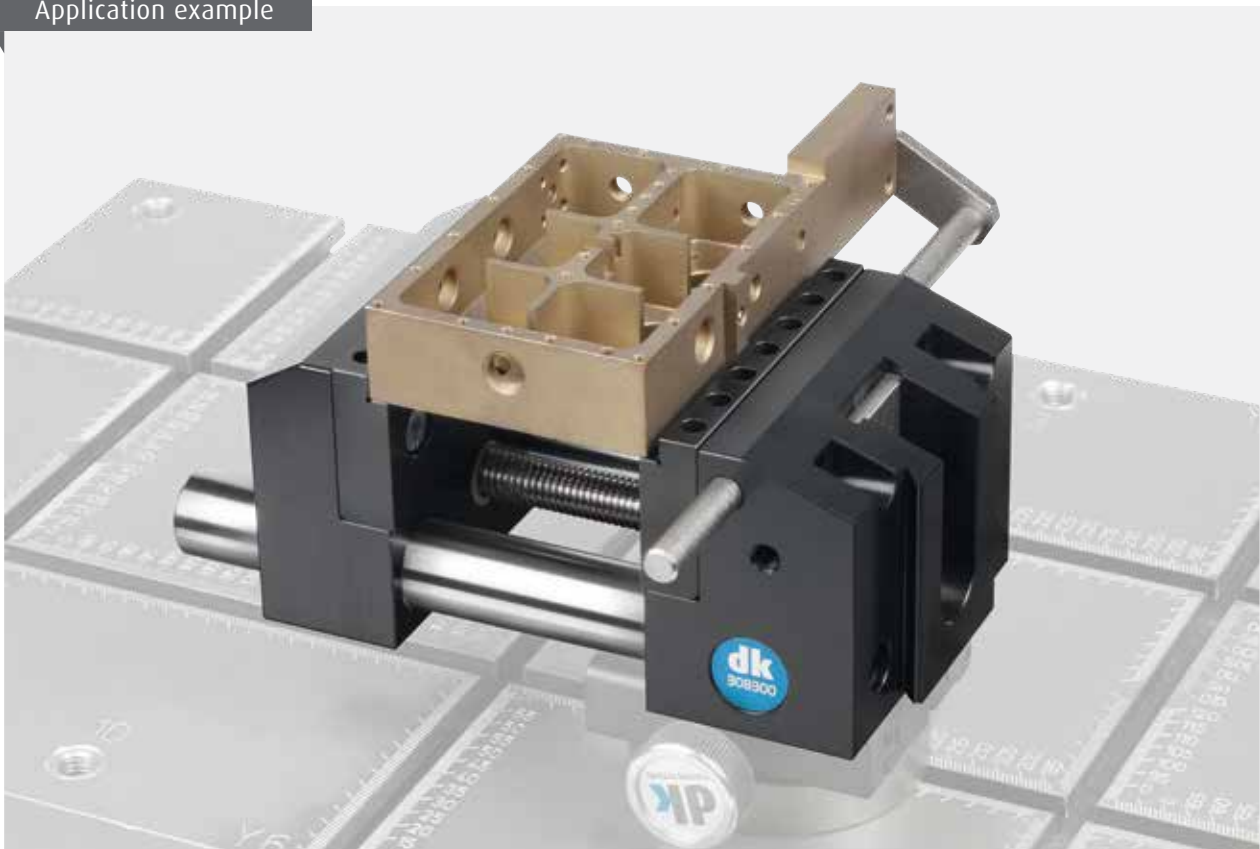

Application example

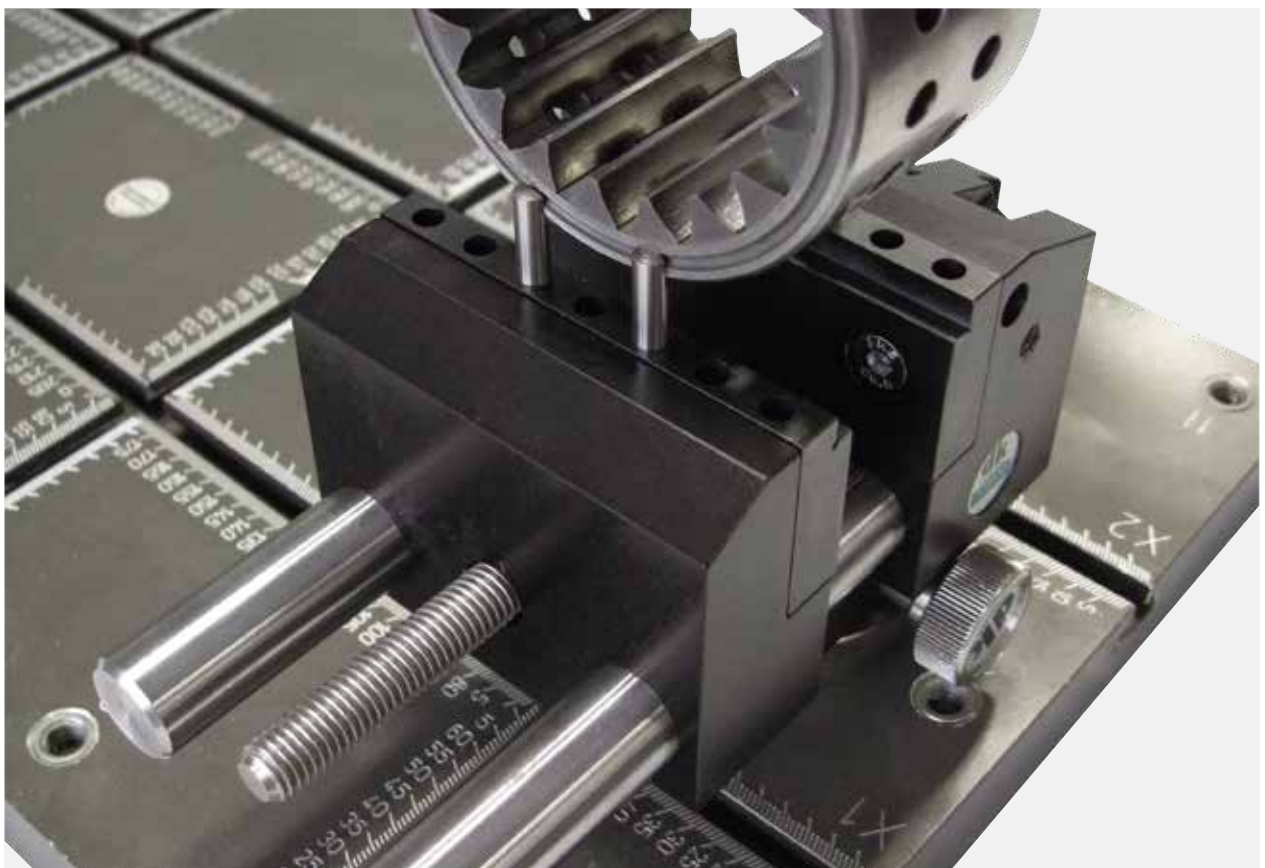

100 mm precision vice

Description

Vice with exchangeable clamping width extension guide shafts. SWA 39 quick-change adapter integrated in the vice base. With stepped jaws and $\varnothing 5$ mm holes for clamping pins.

Material

Hard-coated aluminium with surface hardened steel jaws.

Supplied with

1 adjustable stop (318110), an extra set of shafts for extending the clamping width up to 170 mm, 4 pins and operating tools.



Order No.	Jaw width	Clamping width	Weight
308500	100	80 / 170*	2.45

SWA 39

* Can be extended up to 220 mm with extra shaft sets.

Accessories

+ Shaft set for clamping range extension

Order No.	Material	Jaw width	Supplied with	Description
309600	Surface hardened steel	-	1 set of 2 guide shafts and 1 threaded spindle	for clamping range extension up to 220 mm



+ Smooth jaws

Order No.	Material	Jaw width	Contents	Description
308700	Stainless steel	100	1 set	-



+ Form jaws with small prisms

Order No.	Material	Jaw width	Supplied with	Clamping diameter
309000	Stainless steel	100	1 set jaws one smooth and one prism jaw	recommended vertical and horizontal from 5 mm



+ Form jaws with prisms for end-face clamping

Order No.	Material	Jaw width	Contents	Clamping diameter
309301	Stainless steel	100	1 set	recommended from 20 to 120 mm



+ Clamping pins, stepped

Order No.	Contact face	Length	Contents	Description
307800	Straight	26 x Ø5	Set of 4	for raised part positioning
307810	Straight	36 x Ø5	Set of 4	
326600	120° prism	30 x Ø5	2 prism pairs	
326610	120° prism	35 x Ø5	2 prism pairs	



+ Universal stop

Order No.	Material	Supplied with
277510	Steel	2 exchangeable stop points



+ Stops for vices

Order No.	Material	Length	Overhang	Description
318100	Steel	50	20	
318200	Steel	50	40	
318110	Steel	150	20	
318210	Steel	150	40	



Application example

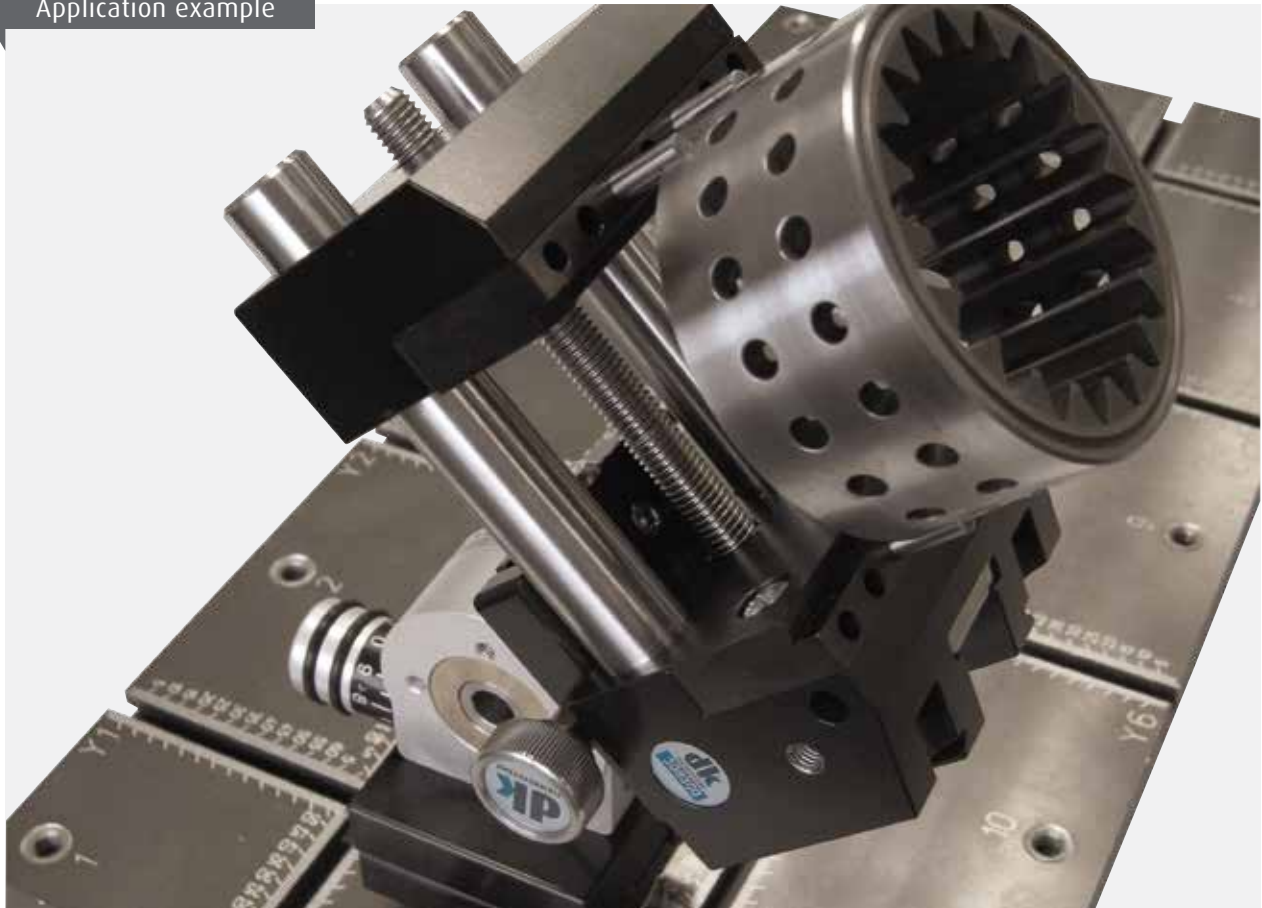

125 mm precision vice

Description

Vice with exchangeable clamping width extension guide shafts. SWA 39 quick-change adapter integrated in the vice base. With stepped jaws and $\varnothing 6$ mm holes for clamping pins.

Material

Hard-coated aluminium with surface hardened steel jaws.

Supplied with

1 adjustable stop (318110), an extra set of shafts for extending the clamping width up to 170 mm, 4 pins and operating tools.



Order No.	Jaw width	Clamping width	Weight
308600	125	80 / 170*	3.30

SWA 39

* Can be extended up to 220 mm with extra shaft sets.

Accessories

+ Shaft set for clamping range extension

Order No.	Material	Jaw width	Supplied with	Description
309600	Surface hardened steel	-	1 set of 2 guide shafts and 1 threaded spindle	For clamping range extension up to 220 mm



+ Smooth jaws

Order No.	Material	Jaw width	Contents	Description
308820	Stainless steel	125	1 set with fastening screws	-



+ Form jaws with small prisms

Order No.	Material	Jaw width	Supplied with	Clamping diameter
309400	Stainless steel	125	1 set jaws one smooth and one prism jaw	recommended vertical and horizontal from 5 mm



+ Form jaws with prisms for end-face clamping

Order No.	Material	Jaw width	Contents	Clamping diameter
309501	Stainless steel	125	1 set	25 to 180 mm



+ Clamping pins, stepped

Order No.	Contact face	Length	Contents	Description
307850	Straight	32 x Ø6	Set of 4	for raised part positioning
326650	120° prism	30 x Ø6	2 prism pairs	



+ Universal stop

Order No.	Material	Supplied with
277510	Steel	2 exchangeable stop points



+ Stops for vices

Order No.	Material	Length	Overhang	Description
318100	Steel	50	20	
318200	Steel	50	40	
318110	Steel	150	20	
318210	Steel	150	40	



Application example

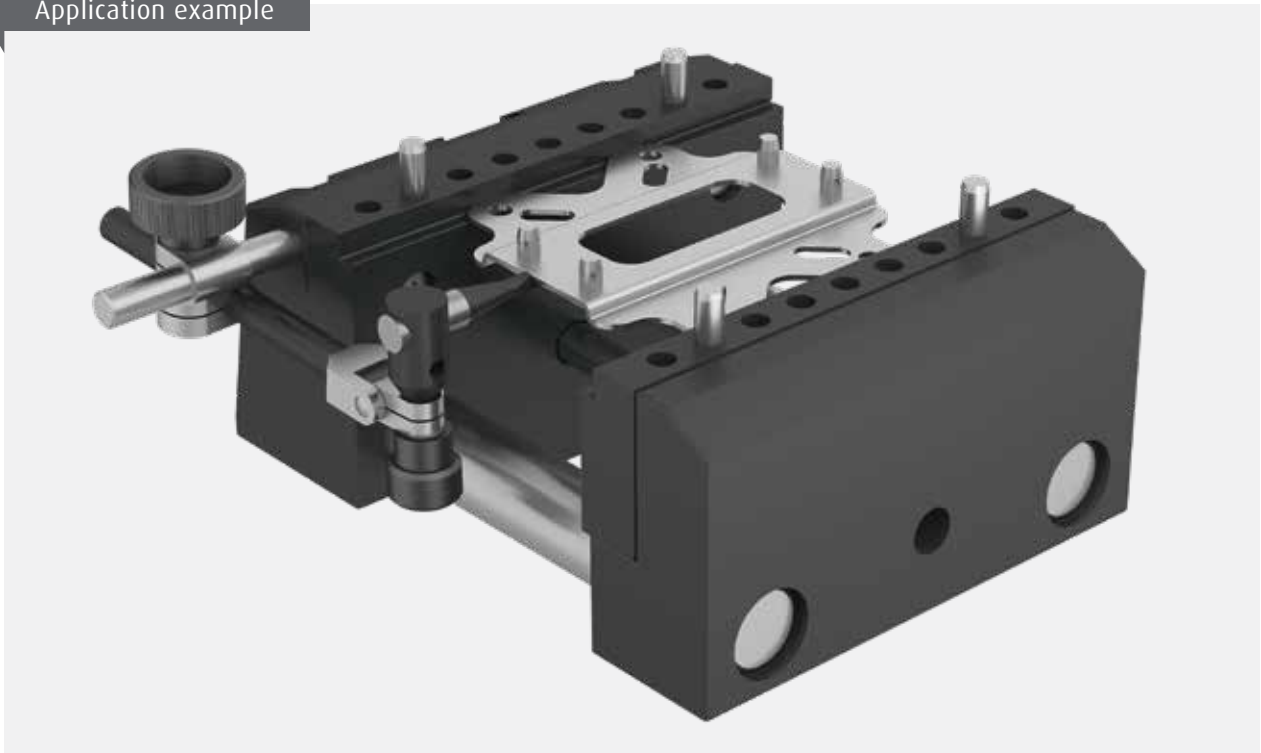

Precision mini chuck

Description

Precision mini chuck with externally offset clamping jaws. For internal and external clamping of rotationally symmetrical parts. Mounted on an SWA 39 or SWA 5 quick-change adapter.

Material

Hard-coated aluminium/steel.



SWA 39

SWA 5

Order No.	Connection	Int. clamping Ø	Ext. clamping Ø	Height	Diameter	Fig.
283700	SWA 39	0.2-3	3-5	59	24	
283900	SWA 39	0.5-5	5-9	79	32	1
283600	SWA 5	0.2-3	3-5	60	24	2
283800	SWA 5	0.5-5	5-9	80	32	

Application example



Precision collet chuck ER 16

Description

ER 16 collet chuck for 0.5–10 mm collets. With SWA 39 quick-change adapter.



Application example



Order No.	Version	Length	Width	Height	Weight
283480	ER 16	60	60	65	0.35

Accessories

+ Collets

Order No.	Material	Clamping Ø	Description
263400	Steel	0.5–1	collets suitable for collet chuck ER 16
263401		1–2	
263402		2–3	
263403		3–4	
263404		4–5	
263405		5–6	
263406		6–7	
263407		7–8	
263408		8–9	
263409		9–10	



+ Complete set of collets

Order No.	Material	Clamping Ø	Description
263450	Steel	0.5–10	Complete set of collets 0.5–10 mm (parts 263400–263409) for ER 16 collet chuck

Description

General information about our dk precision three-jaw chucks

dk precision three-jaw manual chucks represent quality, precision and smooth operation. The compact design and use of aluminium for the 100 mm and 160 mm version bodies make the chucks easy and ergonomic to operate with metrology machines. The 34 mm to 100 mm sizes are fitted with reversible jaws, providing a wide clamping range for internal and external clamping. Exchange jaws are available as accessories with the 160 mm chuck. The diverse interfaces make the chucks compatible with the measurement fixating systems from dk.

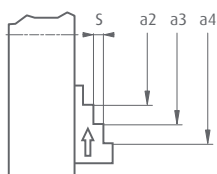
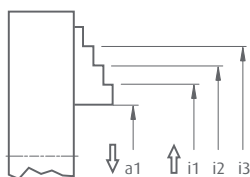
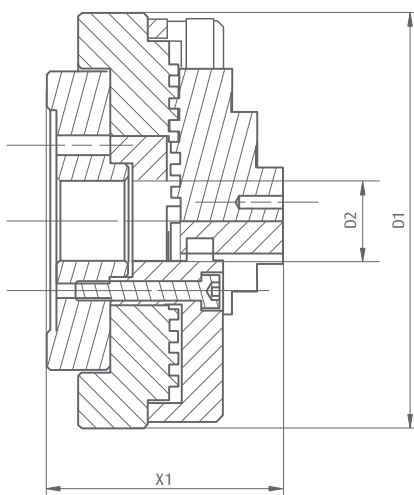

Technical data

	34 mm	50 mm	65 mm	100 mm	160 mm
d1	35	52.5	65	106	162
d2	12	11	13	15	34
x1	18.5	37.5	37.5	47.5	80

Clamping range

	34 mm	50 mm	65 mm	100 mm	160 mm
i1	11-23	17-35	17-47	20-60	38-100
i2		35-53	35-65	40-80	90-160
i3				60-100	
a1	1-14	1-18	1-30	1-40	2.5-70
a2	20-32	18-36	18-48	28-66	42-120
a3		36-54	36-66	48-84	100-160
a4				68-102	
s	4.3	4	4	4.5	10

Interfaces

Interface	34 mm	50 mm	65 mm	100 mm	160 mm
SWA 39	329000	329705	329700	283220	330310
SWA 5	329010				
3 x M2	329030				
3 x M4		329720	329710		
4 x M6				283225	330315
Plate 30x30x8	329020				
MK 2		329725	329715		



SWA 39



3 x M4



MK 2



SWA 5

Application examples

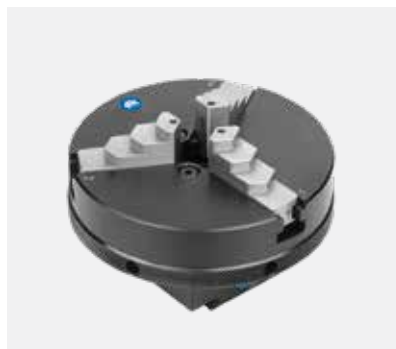

34 mm precision three-jaw chuck

Description

Hand operated three-jaw chuck with tool-free reversible jaws for internal and external clamping of rotationally symmetrical work-pieces.

Chuck precision without further attachments:

Radial run-out < 0.03 mm

Axial run-out < 0.01 mm

Repeat accuracy < 0.01 mm

With an SWA 39 quick-change adapter.

Also available with an SWA 5 quick-change adapter that can also be held on the 14 mm OD.

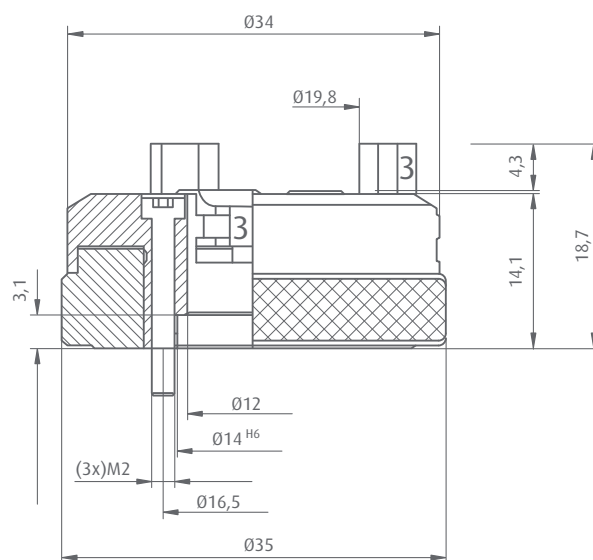
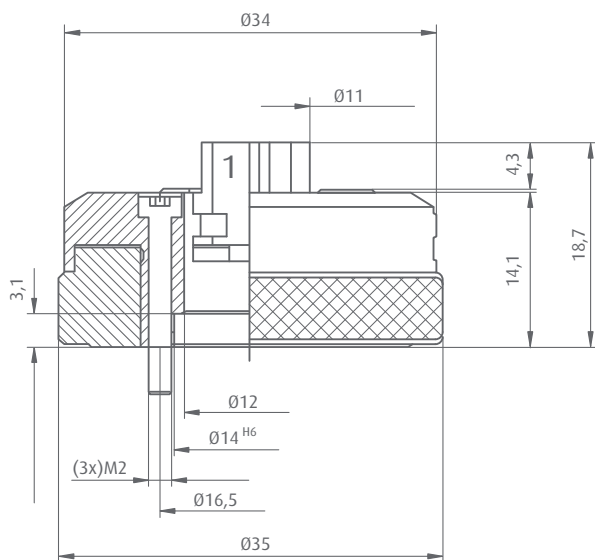

Order No.	Size	Connection	Height
329000	34	SWA 39	72
329010	34	SWA 5	38.5
329020	34	Plate 30x30x8	26.5
329030	34	3x M2 on D 16.5	18.5

Please note: Part 329030 can only be used in conjunction with customer-specific attachments!

Application example



50 mm precision three-jaw chuck

Description

Hand operated three-jaw chuck with tool-free reversible jaws for internal and external clamping of rotationally symmetrical workpieces. With pin holes and 2 sets of pins of different lengths for elevating parts for access from all sides.

Pin holes $\varnothing 2 \times 7$ mm deep.

Chuck precision without further attachments:

Radial runout < 0.03 mm

Axial run-out < 0.01 mm

Repeat accuracy < 0.01 mm

With an SWA 39 quick-change adapter.

Also available with fastening holes or MK 2 Morse taper.

Material

Steel and hard-coated aluminium.

Supplied with

Operating tools and 2 sets of 3 pins 12 mm and 18 mm long.



2



3

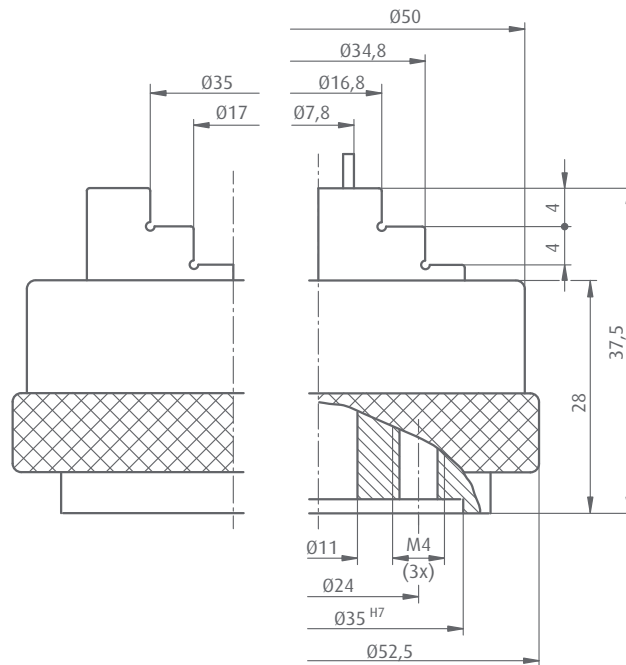

Order No.	Size	Connection	Height	Fig.
329705	50	SWA 39	58	1
329720	50	3x M4	38	2
329725	50	MK 2*	46.5	3

* Other adapter types available on request.



+ Seating spacers for 3-jaw chucks

Description

A set of spacers used to limit the depth a workpiece is set in the jaws and ensure repeat setup accuracy.

Material

Engineering plastic.

Contents

3 spacers with different heights.



Order No.	Suitable for	Contents	Height 1	Height 2	Height 3
283250	50 mm and 65 mm 3 jaw chucks	Set of 3	3	5	7

+ Soft jaws for 3-jaw chucks

Description

A set of soft jaws for machining to suit specific applications.

Material

Bronze



Order No.	Suitable for	Contents
329730	50 mm and 65 mm 3-jaw chucks	Set of 3

Application example



65 mm precision three-jaw chuck

Description

Hand operated three-jaw chuck with tool-free reversible jaws for internal and external clamping of rotationally symmetrical workpieces. With pin holes and 2 sets of pins of different lengths for elevating parts for access from all sides.

Pin holes $\varnothing 2 \times 7$ mm deep.

Chuck precision without further attachments:

Radial runout < 0.03 mm

Axial run-out < 0.01 mm

Repeat accuracy < 0.01 mm

With an SWA 39 quick-change adapter.

Also available with fastening holes or MK 2 Morse taper..

Material

Steel and hard-coated aluminium.

Supplied with

Operating tools and 2 sets of 3 pins 12 mm and 18 mm long.

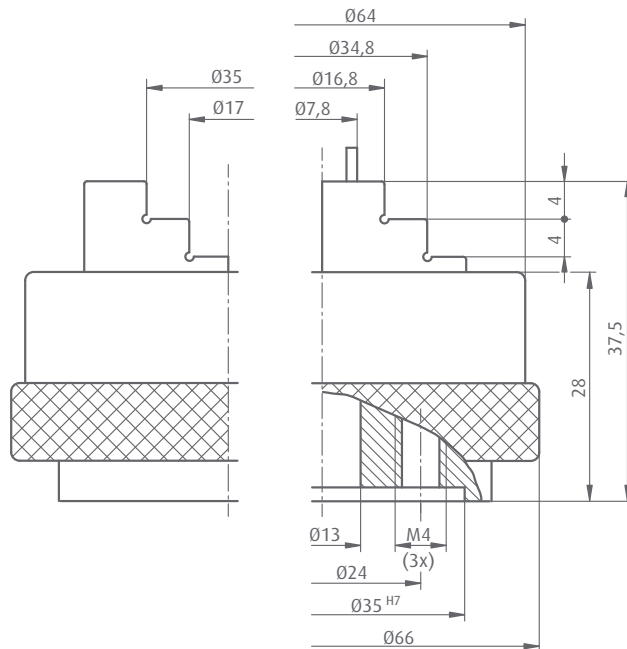

Order No.	Size	Connection	Height	Fig.
329700	65	SWA 39	58	1
329710	65	3x M4	38	2
329715	65	MK 2*	46.5	3

* Other adapter types available on request.



+ Seating spacers for 3-jaw chucks

Description

A set of spacers used to limit the depth a workpiece is set in the jaws and ensure repeat setup accuracy.

Material

Engineering plastic.

Contents

3 spacers with different heights.

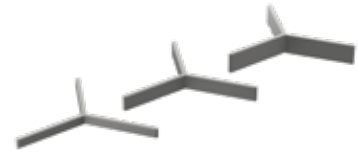

Order No.	Suitable for	Contents	Height 1	Height 2	Height 3
283250	50 mm and 65 mm 3-jaw chucks	Set of 3	3	5	7

+ Soft jaws for 3-jaw chucks

Description

A set of soft jaws for machining to suit specific applications.

Material

Bronze



Order No.	Suitable for	Contents
329730	50 mm and 65 mm 3-jaw chucks	Set of 3

Application example



100 mm precision three-jaw chuck

Description

Hand operated three-jaw chuck with tool-free reversible jaws for internal and external clamping of rotationally symmetrical workpieces. With $\varnothing 3 \times 8$ mm deep pin holes and 3 sets of pins of different lengths for elevating parts for access from all sides. Chuck precision without further attachments:
 Radial runout < 0.03 mm
 Axial run-out < 0.01 mm
 Repeat accuracy < 0.01 mm
 Aluminium housing for weight reduction.
 With an SWA 39 quick-change adapter.
 Also available with fastening holes.



Material

Hard-coated aluminium. Hardened steel jaws.

Supplied with

Operating tools and 3 sets of pins 12 mm, 18 mm and 24 mm long.

↪ For hole dimensions for part 283225 see page 72.

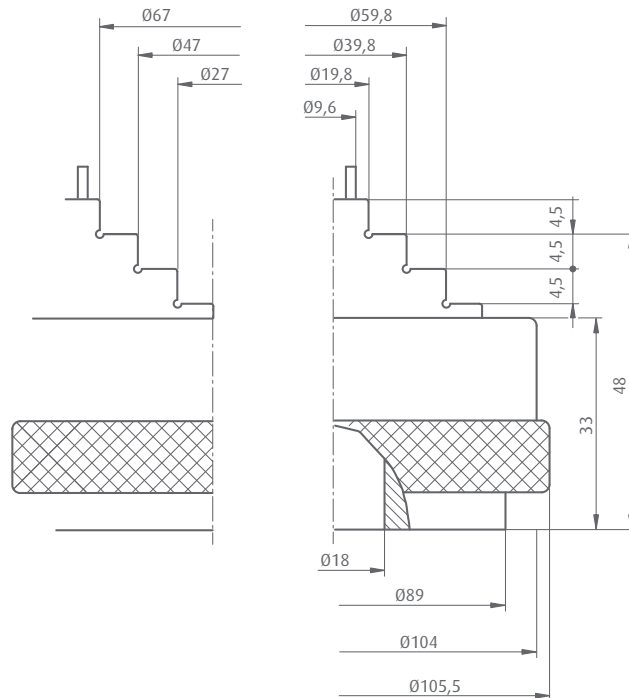

Order No.	Size	Version	Height	Weight
283220	100	SWA 39	80	1.9
283225	100	4x M6	60	1.7



+ Seating spacers for 3-jaw chucks

Description

A set of spacers used to limit the depth a workpiece is set in the jaws and ensure repeat setup accuracy.

Material

Engineering plastic.

Contents

3 spacers with different heights.



Order No.	Suitable for	Contents	Height 1	Height 2	Height 3
283255	100 mm and 160 mm 3-jaw chucks	Set of 3	5	8	12

+ Soft jaws for 3-jaw chucks

Description

A set of soft jaws for machining to suit specific applications.

Material

Soft steel.



Order No.	Suitable for	Contents
283230	100 mm 3-jaw chuck	Set of 3

Application example



160 mm precision three-jaw chuck

Description

Hand operated three-jaw chuck with tool-free reversible jaws for internal and external clamping of rotationally symmetrical workpieces. With $\varnothing 4 \times 8$ mm deep pin holes and 2 sets of pins of different lengths for elevating parts for access from all sides.

With an SWA 39 quick-change adapter.

Also available with fastening holes.

Material

Hard-coated aluminium. Hardened steel jaws.

Supplied with

Operating tools and 2 sets of 3 pins 18 mm and 24 mm long.



Hole dimensions below are for 160 mm and 100 mm chucks.

Connections underneath

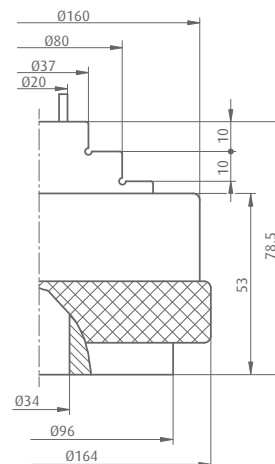
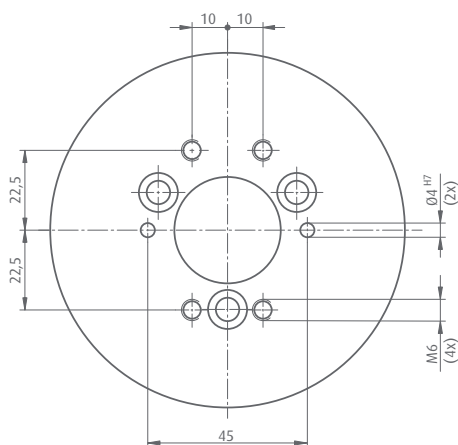

Order No.	Size	Version	Height	Weight
330310	160	SWA 39	102	4.9
330315	160	4x M6	82	4.7

SWA 39

M ...

Accessories

+ OD chuck jaws

Order No.	Material	Size	Contents	Description
330311	Steel	160	Set of 3 jaws	Hardened



+ Soft jaws

Order No.	Material	Size	Contents	Description
330312	Steel	160	Set of 3 jaws	Soft



+ Seating spacers for 3-jaw chucks

Description

A set of spacers used to limit the depth a workpiece is set in the jaws and ensure repeat setup accuracy.

Material

Engineering plastic.

Contents

4 spacers with different heights.



Order No.	Suitable for	Contents	Height 1	Height 2	Height 3	Height 4
283260	160 mm chuck	Set of 4	5	8	12	18

Application example

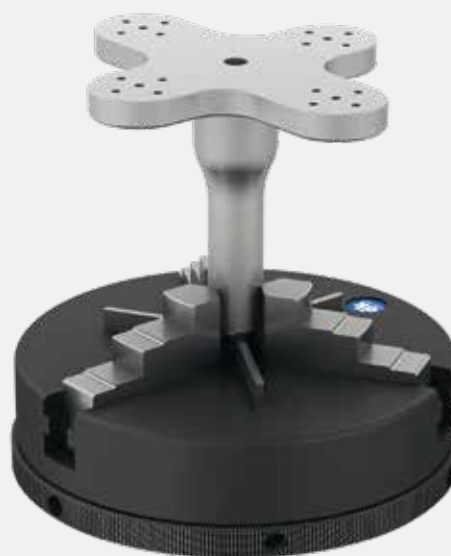

Rotary table with precision three-jaw chuck

Description

Rotary mounted three-jaw manual chuck with high concentricity. For internal and external clamping of rotationally symmetrical parts. With $\varnothing 2 \times 7$ mm deep holes and 2 sets of pins of different lengths for elevating parts for access from all sides. Available with an SWA 39 quick-change adapter or base plate.

Material

Hard-coated aluminium. Hardened steel jaws.

Supplied with

Operating tools and 2 sets of pins 12 mm and 18 mm long.



Application example



Order No.	Size	Version	Radial runout	Height
267365	50	Base plate	+/- 0.025	71
267370	50	SWA 39	+/- 0.025	71
267355	65	Base plate	+/- 0.025	71
267360	65	SWA 39	+/- 0.025	71

SWA 39

M ...

Application example



NADELFIX: fix-variable self-moulding from products

Function

Workpieces with complicated free-form geometries for which no conventional clamping equipment exists can be securely and reproducibly fixated and held with *NADELFIX*. Parts to be tested are pressed into a bed of individually sprung pins or needles which are then locked in place by a central clamp. This rapidly produced exact negative form of the test piece perfectly holds the part in place with minimum clamping force using e.g. a spring finger. There is no surface damage, as with normal vices, nor are there unreliable, improvised fixations.

Advantages

- Excellent suitability for free-form surfaces
- Secure and gentle hold through positive fit with minimum clamping force
- Time saving and cost effective due to rapid adjustment to variable workpiece geometries
- Universal clamping element rather than manufacturing and storing product-specific special fixtures
- Simple and tool-free operating principle
- Can be combined with other dk product ranges
- Modular system with a wide range of possible applications

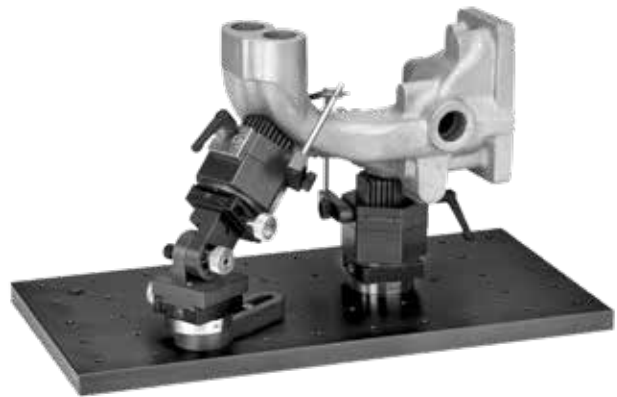

NADELFIX 2.5

Description

Ideal for clamping moulded parts.
With an SWA 39 quick-change mount.

Supplied with

A clamping fixture comprising rail (396120), column (269043) and spring finger (269038). Fasteners also included.



Application example

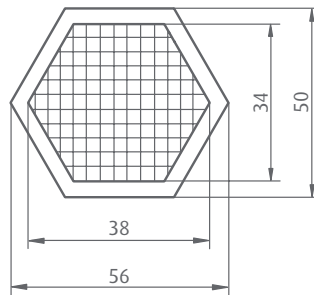

Order No.	Pin Ø	Support surface	Total height	Spring travel
396030	2.5	38 x 34	55	max. 10



NADELFIX 5 Mini

Description

Ideal for clamping moulded parts.
Available with an SWA 39 quick-change mount or an SWA 8 quick-change mount for flexible use on articulated arms.

Supplied with

A clamping fixture, comprising rail (396110), column (368300) and spring finger (302800). Fasteners are included.

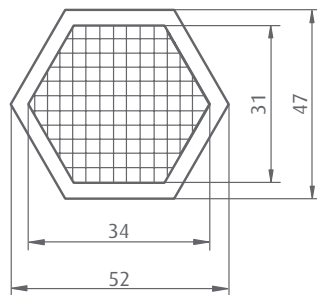

SWA 8 SWA 39

Order No.	Pin Ø	Support surface	Total height	Spring travel	Interface	Fig.
396000	5	34 x 31	90	max. 12	SWA 39	1
396005	5	34 x 31	80	max. 12	SWA 8	2

NADELFIX 5 Midi

Description

Ideal for clamping moulded parts.
With an SWA 39 quick-change mount.

Supplied with

A clamping fixture, comprising rail (396110), column (368300) and spring finger (302800). Fasteners are included.

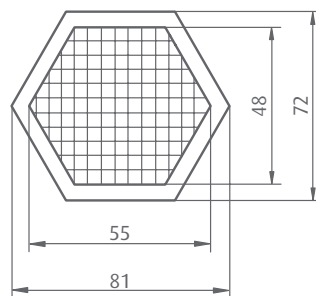

SWA 39

Order No.	Pin Ø	Support surface	Total height	Spring travel
396010	5	55 x 48	80	max. 12

NADELFIX 5 Maxi

Description

Ideal for clamping moulded parts.
With an SWA 39 quick-change mount.

Supplied with

A clamping fixture, comprising rail (396100), column (368300) and spring finger (302800).
Fasteners are included.

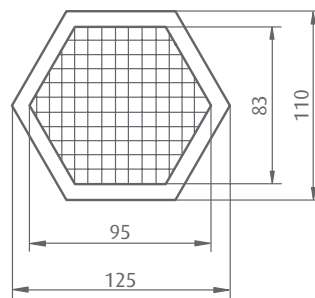

Order No.	Pin Ø	Support surface	Total height	Spring travel
396020	5	95 x 83	90	max. 12

SWA 39

Application example



+ Attachment rails

Description

For flexible positioning of spring fingers on "NADELFIX".

Material

Hard-coated aluminium.



Order No.	Total length	Adjustment range	Thread
396120	50	34	M4
396110	60	33	M6

+ Columns for spring fingers

Description

Columns for mounting spring fingers.

Material

Stainless steel.



Order No.	Column Ø	Thread	Length
269042	4	M 4	30
269043	4	M 4	50
269044	4	M 4	75
368100	6	M 6	30
368200	6	M 6	50
368300	6	M 6	75
368400	6	M 6	100
368500	6	M 6	125

+ Spring fingers

Description

For quickly and easily holding test parts.

Material

Stainless steel.

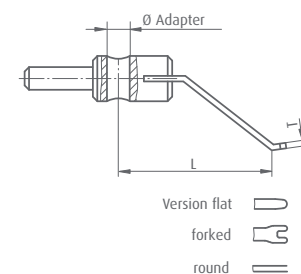

Order No.	Adapter Ø	T	L	Version	Fig.
269037	4	0.4	30	Flat	1
343700	4	0.8	30	Flat	
269038	4	1.1	40	Round	
269039	4	1.1	60	Round	
302800	6	1	50	Flat	
302900	6	1	75	Flat	

Small-parts clamp, smooth

Description

Small-parts clamp with smooth jaws. Available with an SWA 39 quick-change adapter or with M 6 female thread.

Material

Hard-coated aluminium/steel.

Application example



1



2

Order No.	Version	Jaw width	Width (W)	Height	Fig.
275600	SWA 39	12	0.5-5	100	
276000	SWA 39	18	1.5-8	100	1
276200	SWA 39	25	3-10	120	
390200	M 6	12	0.5-5	80	
391600	M 6	18	1.5-8	80	2
276210	M 6	25	3-10	100	

SWA 39

SWA 6

Small-parts clamp, stepped jaw one side

Description

Small-parts clamp with stepped jaw one side. Available with an SWA 39 quick-change adapter or with M 6 female thread.

Material

Hard-coated aluminium/steel.

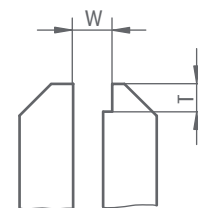

Application example



Order No.	Version	Jaw width	Width (W)	Depth (T)	Height	Fig.
275700	SWA 39	12	1-5	2	100	
276100	SWA 39	18	2.5-8	2	100	1
276300	SWA 39	25	4-10	2	120	
390300	M 6	12	1-5	2	80	
391500	M 6	18	2.5-8	2	80	2
276310	M 6	25	4-10	2	100	

SWA 39

SWA 6

Small-parts clamp with horizontal prism

Description

Small-parts clamp with horizontal prism jaws. For clamping rotationally symmetrical parts. Available with an SWA 39 quick-change adapter or with M 6 female thread.

Application example



2



1

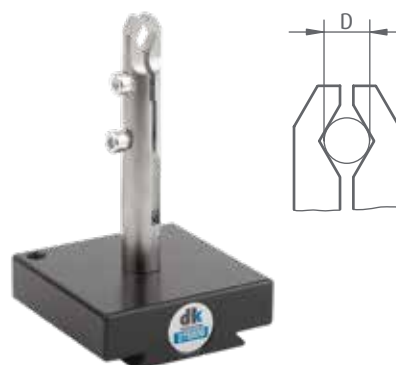

Order No.	Version	Clamping \varnothing (D)	Jaw width	Height	Fig.
275800	SWA 39	3.2-6	3.5	100	
275900	SWA 39	5-8.5	5	100	1
275810	M 6	3.2-6	3.5	80	
275910	M 6	5-8.5	5	80	2

SWA 39

SWA 6

Small-parts clamp with end-face prism

Description

Small-parts clamp with prismatic top face and stepped jaws for holding rotationally symmetrical parts. Mounted on an SWA 39 quick-change adapter or with an M6 female thread.

Application example



2



1



Order No.	Version	Clamping \varnothing	Width (W)	Depth (T)	Height	Fig.
277305	SWA 39	3-25	3-6	2	100	1
277320	SWA 39	5-35	4-10	2	100	
277300	SWA 39	6-55	4-12	3	120	
390010	M 6	3-25	3-6	2	80	2
277315	M 6	5-35	4-10	2	80	
277325	M 6	6-55	4-12	3	100	

SWA 39

M 6

Small-parts clamp for internal clamping

Description

Small-parts clamp for holding workpieces in the bore. The clamping diameter is stepped in 3 mm increments (276800 + 276805 first step = 4 mm).

Mounted on an SWA 39 quick-change adapter or with an M6 thread.



Order No.	Version	Clamping Ø	Step depth	Height	Fig.
276800	SWA 39	5-30	2	120	1
276805	M 6	5-30	2	100	2

SWA 39

M 6

Application example



Stop for small-parts clamps

Description

Stop for reproducible clamping of small parts on all types of small-parts clamps with SWA 39 adapter.

Supplied with

M6 connection screw, a flat point and Ø2 mm ball point (M2.5 screw on points).



Order No.

Overhang

277500

100

M 6

Application example



Permanent magnetic clamping fixture

Description

Permanent magnetic plate for the quick and easy holding of steel parts. Mounted on an SWA 39 quick-change adapter.

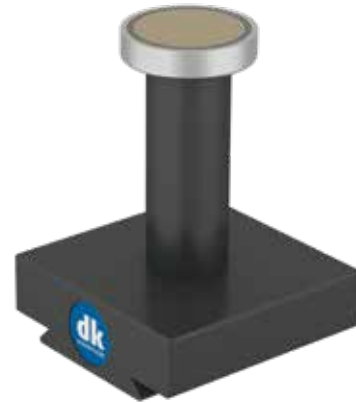

Order No.	Height	Magnet Ø	Magnetic force (N)	Weight
278000	80	32	350	0.29

SWA 39

Magnetic clamping fixture with on/off switch

Description

Permanent magnet with on/off switch for the quick and easy holding of steel parts. Mounted on an SWA 39 quick-change adapter.



Order No.	Height	Magnet Ø	Magnetic force (N)	Weight	Fig.
278200	70	50	85	0.86	1
278210	85	80	500	2.50	

SWA 39

Magnetic V-block, permanent

Description

Permanent magnetic 90° V-block for holding rotationally symmetrical parts. Mounted on an SWA 39 quick-change adapter.

Material

Hard-coated aluminium.



Order No.	Clamping range	Prism depth	Magnetic force (N)	Height
313700	Ø 15–35	16	15	100

SWA 39

Magnetic V-block with on/off switch

Description

Magnetic V-block with on/off switch for holding rotationally symmetrical parts. With mounting hole for adjustable length stop. Mounted on an SWA 39 quick-change adapter.

Material

Hard-coated aluminium/steel.

↳ See pages 43 and 46 for length stop.



Order No.	Clamping range	Prism depth	Magnetic force (N)	Height
278300	Ø 5–50	37	800	80
278310	Ø 5–50	67	1000	80

SWA 39

Small V-block with spring finger

Description

Small 120° V-block for holding rotationally symmetrical parts with spring fingers.

Mounted on an SWA 39 quick-change adapter.

Material

Aluminium/stainless steel.

Supplied with

Bracket (343800) and spring finger (343700).



Order No.	Clamping range	Prism depth	Prism width	Connection	Height	Fig.
277410	Ø 2-25	10	30	SWA 39	65	1
277400	Ø 2-25	25	30	SWA 39	45	2
267900	Ø 2-25	25	30	SWA 5	25	3

SWA 39

SWA 5

Application examples

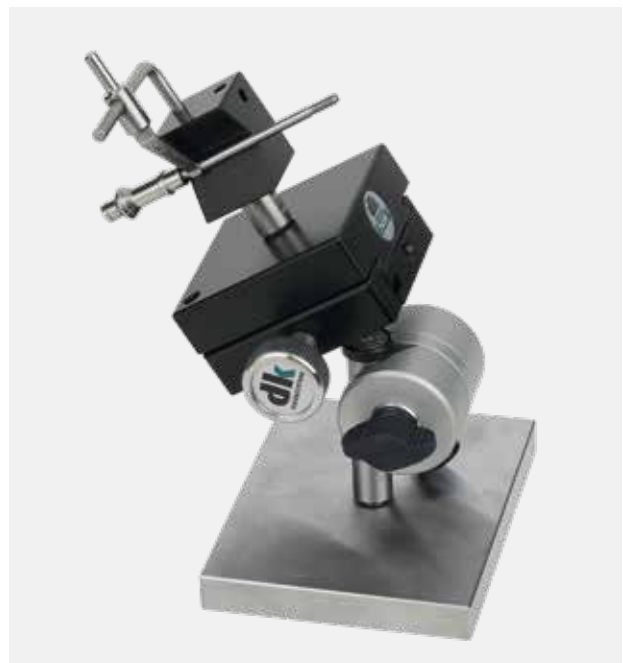

V-block

Description

120° V-block for mounting rotationally symmetrical test parts. Adjustable length stop for reproducible clamping. With an SWA 39 quick-change adapter on the V-block base and SWA 8 connection option (272700 only). Also with lateral slots and tapped holes for mounting a tensioning strap fixture, U-clamp or spring finger.

Material

Hardened steel.

Supplied with

Adjustable length stop (318110).

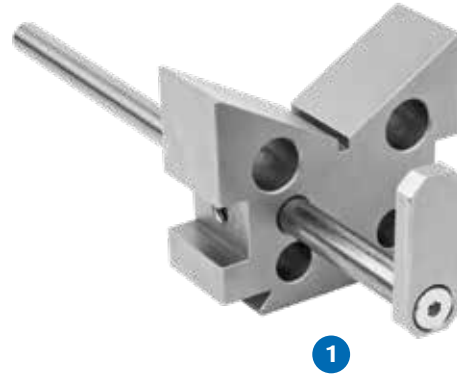

Order No.	V-block length	V-block width	Prism	Fig.
272700	20	60	120°	1
272810	60	60	120°	

SWA 39

SWA 8

Application example



+ U-clamp

Description

For clamping rotationally symmetrical parts.

Material

Aluminium.



Order No.

272920

Clamping range

Ø 4–45 (for 120° V-block)

+ Spring finger with mount

Description

For quickly and easily holding parts.

Supplied with

Spring finger (302800), Column (368300) and Column holder (272910).



Order No.

272930

Clamping range

Ø 4–90 (for 120° V-block)

+ Tensioning strap fixture

Description

Ideal for clamping irregularly shaped parts.

Supplied with

M5 fastening screw, operating tools and 5m tensioning strap.

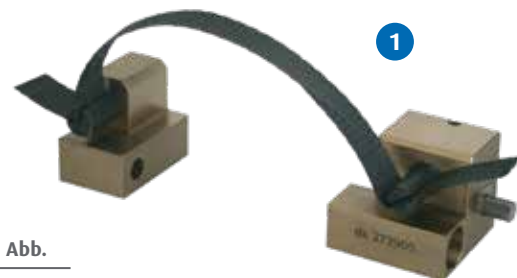

Order No.

272900

Clamping range

Ø 15–100

Description

Standard

Abb.

1

272850

Ø 15–100

Extra strong

272855

Adapter for mounting 272850 on T-slots 6

272902

Adjustable torque wrench

Pair of V-block halves on a T-slot 6

Description

V-blocks halves for T-slots. The clamping range is freely adjustable. With lateral slots and tapped holes for mounting a tensioning strap fixture or spring finger. Part 306500 with mounting hole for stops.

☞ See pages 43 and 46 for length stops (stop for vices).

Material

Hard-coated aluminium/steel.

Supplied with

Screws and slot keys



Order No.	Prism	Block length	Height	Fig.
305500	120°	18	42	1
305700	120°	25	42	
306500	120°	40	52	

T-Nut 6

Application example



+ Adapter plates with T-slot 6

Description

Baseplate with T-slot 6 for mounting various modules e.g. structural elements from the *SPANNFIX* range. With an SWA 39 quick-change adapter for mounting on the SWA 39 basic elements.

Material

Hard-coated aluminium/steel.

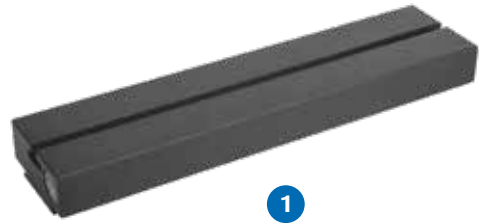

Order No.	Length	Width	Height	Fig.
305000	140	60	24	
305100	250	60	24	1
305110	500	60	24	

T-Nut 6
SWA 39

+ Spring finger with mount

Description

For quickly and easily holding parts.

Supplied with

Adjustable spring finger (302810), column (368500) and column holder (272910).



Order No.	Clamping range
272940	Ø 40-120

See pages 130 and 133 for other spring fingers in *Spannfix PRO* range.

+ Tensioning strap fixture

Description

Ideal for clamping irregularly shaped parts.

Supplied with

M5 fastening screw, operating tools and 5m tensioning strap.

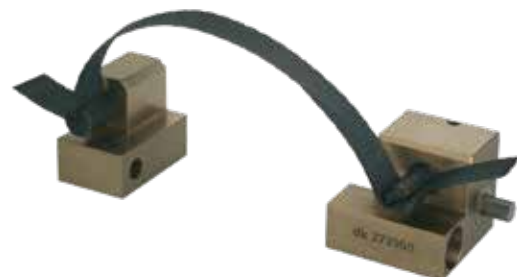

Order No.	Clamping range	Description
272900	From ca. Ø 40	Standard
272850	From ca. Ø 40	Extra strong
272902	Adjustable torque wrench	

Airbase pneumatic glide foot

Description

Basic attachment for SWA 39 modular elements on smooth surfaces. Easy glide on an air cushion. Fix in place by vacuum. Connection module with SWA 39 interface. Maximum load ca. 15 kg. Operating pressure 4.5 to 6 bar. Operate only with dry, oil-free air.

With port for vacuum generation in other elements that may be connected.



Order No.	Length	Width	Height	Weight
270200	300	200	110	3.3

SWA 39

Vacuum plate – round

Description

High-strength aluminium round vacuum plate. With seal grooves and stop for reproducible part setups. ON/OFF switch with rapid air venting. Mounted on an SWA 39 quick-change adapter.

Material

Aluminium.

Supplied with

Seal and connection hose (D 5).



Order No.	Max. vacuum area
294700	Ø 30

SWA 39

Vacuum plate – square

Description

High-strength aluminium vacuum plate. With seal grooves and stops for reproducible part setups. ON/OFF switch with rapid air venting. Mounted on an SWA 39 quick-change adapter.

Material

Aluminium.

Supplied with

Seal and connection hose (D 5).



Order No.

Max. vacuum area

294000

100 x 100

SWA 39

Application example



Clamping sets "A"

Description

Set "A" with basic, structural and key clamping elements. The precision vice and the chuck from the expanded set can both be mounted directly to the quick-action base as a kind of zero-point clamping fixture.

Alternatively, a swivel unit can be mounted in between enabling 3D spatial positioning of the clamping element and workpiece. This enables zero-point clamping with variable alignment, and scales ensure that positions can always be exactly reproduced for different workpieces.

Ordering information

When ordering, select the appropriate quick-action clamp or let us know the thread or T-slot size on your measuring equipment.

Set „A3+“

Set „A3“

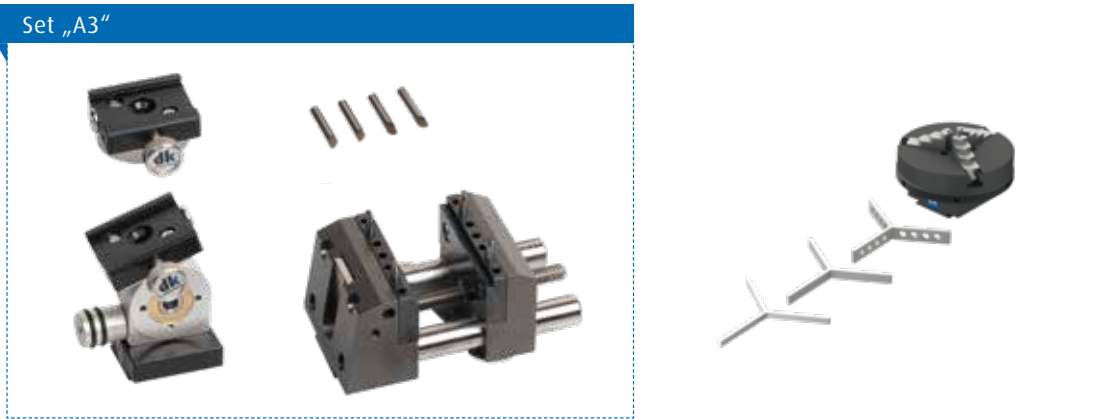

Set versions

Order No.	Description
340530	Clamping set "A3"
340540	Clamping set "A3+"

Set contents

Order No.	Description	Set "A3"	Set "A3+"
308200	80 mm precision vice	1	1
307800	Pins with straight faces for vice jaws (set of 4)	1	1
326600	Pins with prism faces for vice jaws (set of 4)	1	1
283220	100 mm precision three-jaw chuck		1
314010	Quick-action clamp swivel unit	1	1
283255	Seating spacers to raise workpieces for 100 mm chuck, 5 mm, 8 mm and 12 mm high.		1
See below	Quick-action clamp	1	1

Order No.	Fastening
285206	M 6
285208	M 8
285210	M 10
285212	M 12
285300	T-slot

Clamping set "B"

Description

Set "B" with basic, structural and essential clamping elements. The precision vice with a range of accessories, chuck and small-parts clamp can be mounted directly to the quick-action basic clamp as a kind of zero-point clamping fixture. Alternatively, a rotary and swivel unit can be mounted in between enabling 3D spatial positioning of the clamping element and workpiece. This enables zero-point clamping with variable alignment, and scales ensure that positions can always be exactly reproduced for different workpieces.

Ordering information

When ordering, select the appropriate quick-action clamp or let us know the thread or T-slot size on your measuring equipment.

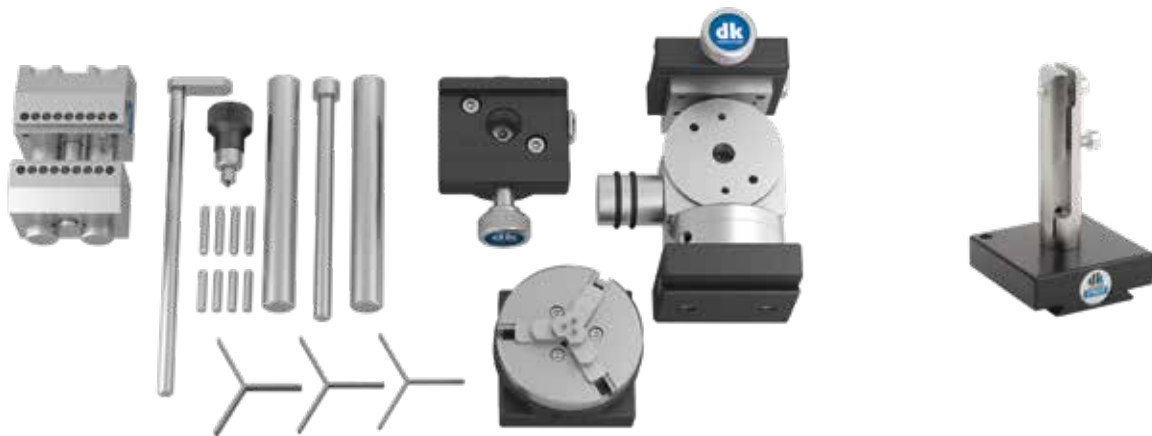

Set versions

Order No.	Description
340615	Clamping set "B"

Set contents

Order No.	Description	Quantity
282100	50 mm vice with accessories	1
329700	65 mm chuck	1
283250	Seating spacers to raise workpieces for 65 mm chuck, 3 mm, 5 mm and 7 mm high.	1
275600	Small-parts clamp, smooth	1
314020	Quick-action rotary and pivot unit clamp	1
See below	Quick-action clamp	
	Order No.	Fastening
	285206	M 6
	285208	M 8
	285210	M 10
	285212	M 12
	285300	T-slot

Clamping set "C"

Description

Set "C" with basic, structural and a range of clamping elements in various sizes. The 50 mm precision vice with a range of accessories, 80 mm vice, 65 mm and 100 mm chucks, small-parts clamp and V-block with stop and U-clamp can be mounted directly to the quick-action basic clamp as a kind of zero-point clamping fixture. Alternatively, a 3D adjustment unit can be mounted in between enabling 3D spatial positioning of the clamping element and workpiece. This enables zero-point clamping with variable, spatial alignment for a variety of workpiece geometries and sizes.

Ordering information

When ordering, select the appropriate quick-action clamp or let us know the thread or T-slot size on your measuring equipment.

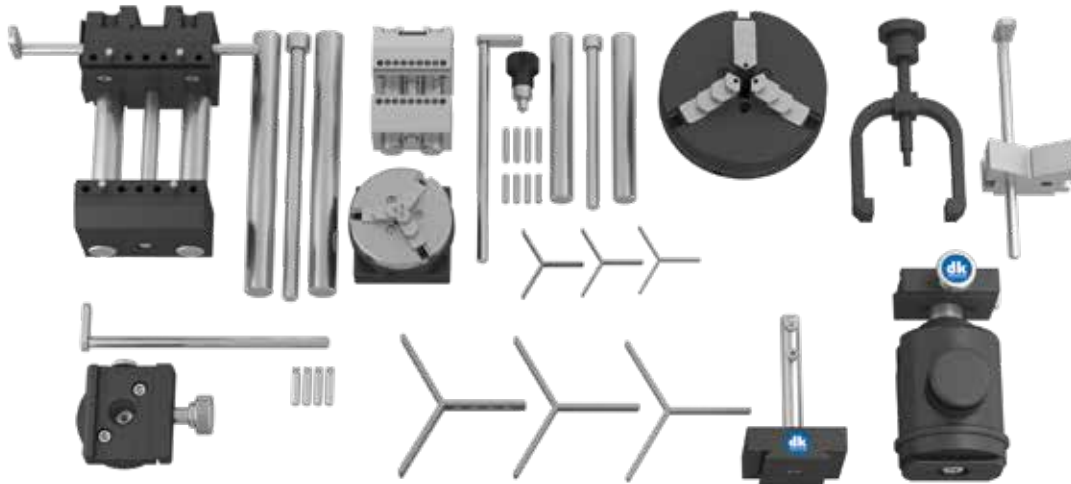

Set versions

Order No.	Description
340700	Clamping set "C"

Set contents

Order No.	Description	Quantity
282100	50 mm vice with accessories	1
282300	Set of stepped pins for 50 mm vice	1
308300	80 mm vice with connections for SWA 39 on 3 faces	1
307800	Set of stepped pins for 80 mm vice	1
329700	65 mm chuck	1
283250	Seating spacers for 65 mm chuck, 3, 5, and 7 mm high.	1
283220	100 mm chuck	1
283255	Seating spacers for 100 mm chuck, 5, 8, and 12 mm high.	1
272700	120° V-block	1
272920	U-clamp for V-block	1

Order No.	Description	Quantity
275600	Small-parts clamp, smooth	1
270500	Swivel unit with ball joint	1
See below	Quick-action clamps	
Order No.	Fastening	
285206	M 6	
285208	M 8	
285210	M 10	
285212	M 12	
285300	T-slot	

Application examples

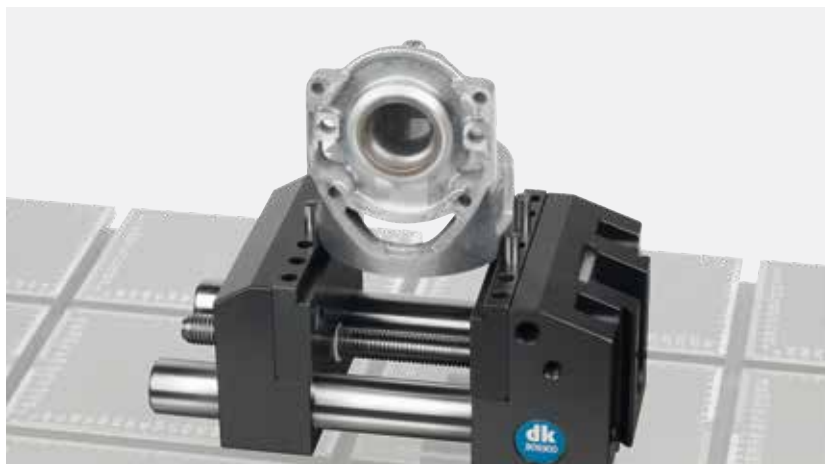

SPANNFIX PRO

Modular clamping elements for tactile measuring

- » The basics are the baseplates or quick-change mounts
- » Exact reproducibility through a slot system with graduations
- » Wide range of structural and clamping elements
- » Flexible clamping solutions diverse workpiece geometries
- » Quick and easy assembly
- » For tactile measuring machines

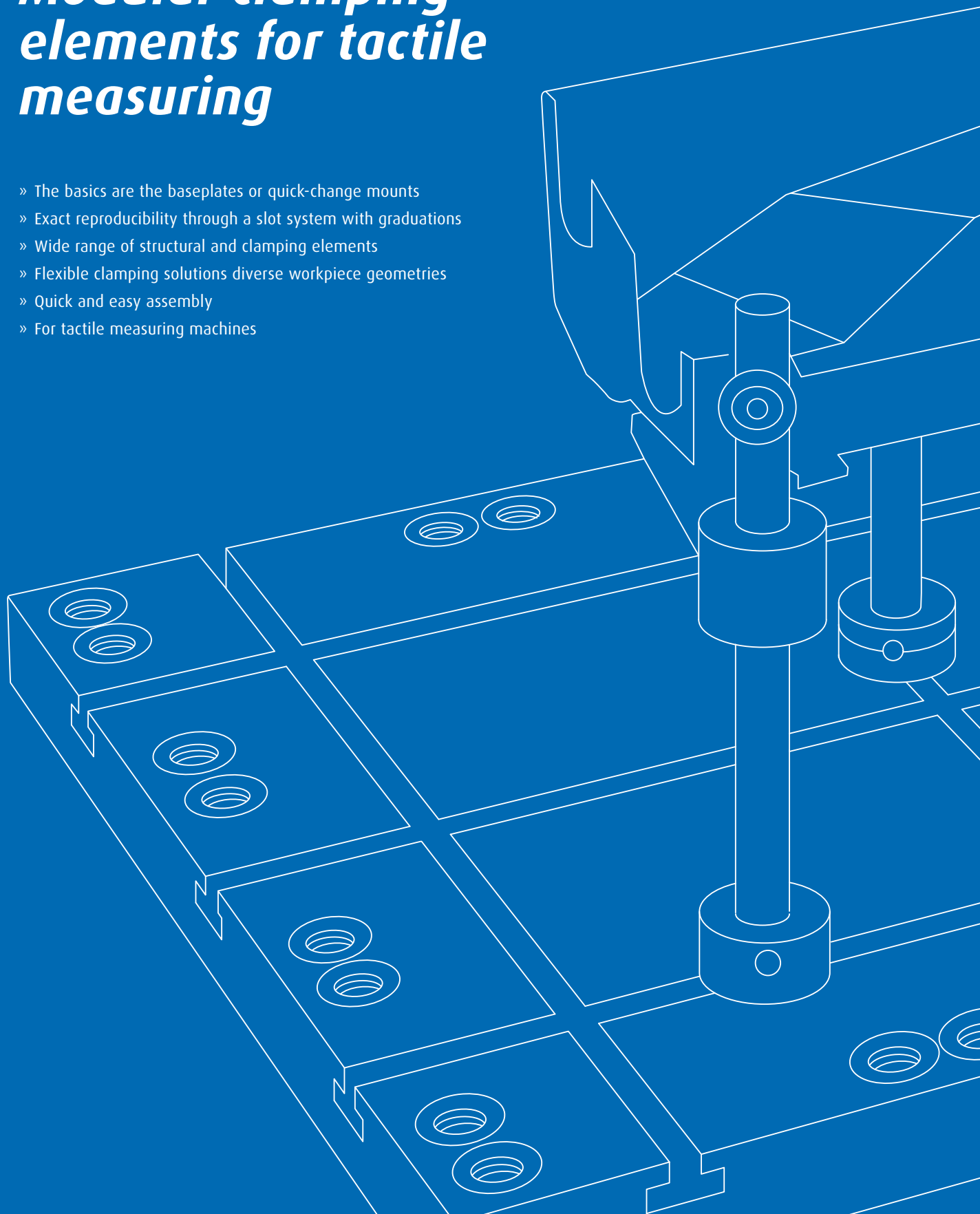

Basic elements
+ accessories



Baseplates with T-slots

Page 104



Intermediate plates

Page 105



Mounting frame with T-slots

Page 106

Structural elements
+ accessories



T-slot nuts

Page 108



T-slot screws

Page 108



Satellite mount with slot key

Page 109



Base rails M 10

Page 110



Base rails M 10 XL

Page 111



Hexagonal extensions M 8 and M 10

Page 112



Self-aligning pads M 10

Page 113



Jack screws M 10

Page 113



Quick-change adapter M 10

Page 114



Screw jack set with spring finger

Page 115



T-slot 6 columns for arm construction, with holder

Page 116



Columns without holder

Page 117



Column cross connector D 12 and M 10

Page 117



Support arm

Page 118



Pins for support arm

Page 119



Bridge supports

Page 120



Mounts with slot

Page 121



Pair V-block halves

Page 121



Adjustable stop

Page 122



Extensions for clamping supports

Page 124



Pairs of V-block halves

Page 125



Side clamp with draw-down jaw

Page 125



Thread reducer

Page 126



Columns with screw

Page 127



Articulated arms

Page 128

Clamping elements
+ accessories



Spring fingers

Page 130



Columns with screw
for spring fingers

Page 131



Adapter plates for
columns

Page 132



Spring finger with
quick-change
adapter

Page 133



Toggle clamp with
support

Page 134



Parallel clamps

Page 136



Parallel clamps
with guide pin

Page 137



Tension clamp

Page 138



Prism support with
spring finger

Page 138



Clips

Page 139



Pair of V-block
halves for moun-
ting directly on
clamping elements

Page 140



Tailstock

Page 142

Vacuum systems
+ accessories



Suction cups

Page 144



Vacuum pumps

Page 146



Vacuum pumps
for compressed air
operation

Page 146

SWA 39 connection
+ accessories



Quick-action clamp
for T-slots

Page 148



SPANNFIX PRO basic set

Page 150



SPANNFIX PRO expansion set

Page 151

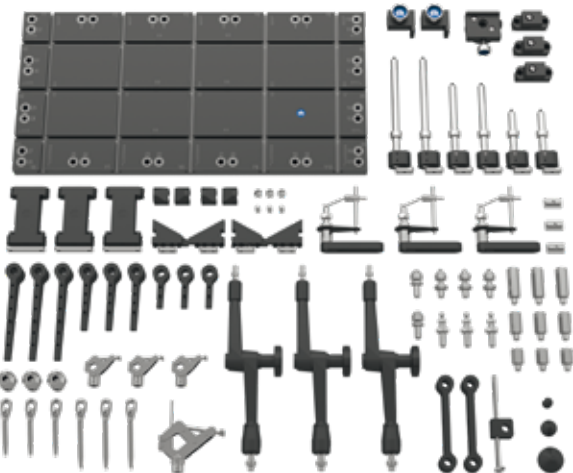

SPANNFIX PRO complete set

Page 152

Precisely reproducible fixtures with scales and angular alignment

SPANNFIX PRO modular system fixtures for exact positioning, fixating and clamping of complex geometries while maintaining maximum workpiece accessibility. Comprising basic, structural and clamping elements which can all be connected to each other over standardised interfaces. In the interests of overall cost-effectiveness and sustainability, the configurations can thus be repeatedly dismantled and rebuilt identically or completely anew. Especially during product development, where changes are usually made, the structure can be easily adapted to changed dimensions or forms. Instead of shelf-filling special clamping elements of classical fixture construction which cannot be adapted, and are therefore scrap after the product life cycle of the test part, professionals use modular systems with intelligent components. Since these only make sense when enough different basic, structural and clamping elements form a functional program, SPANNFIX PRO offers not only a wealth of individual parts, but also their trouble-free combination with other dk fixation systems.



**FAST
REASSEMBLY
LIFELONG**

Basic elements

- 1 Baseplate with T-slots (page 104)
Other baseplates (pages 105-107)



Structural elements

- 2 T-slot 6 columns (page 116)



- 3 Support arm (page 118)



- 4 Satellite mount (page 109)





Clamping elements

- 5 Hexagonal columns M8 + M10 (page 112)
Other columns (pages 116-117)



- 6 Adjustable stop (page 122)



- 7 Spring fingers (page 130)
Others (page 133)



- 8 Toggle clamp with support (page 134)



Baseplates with T-slots

Description

Baseplates with T-slot 6 and connection threads. With scale for exact and reproducible positioning of fixture elements.

Material

Hard-coated aluminium / Stainless steel tapped bushes

↳ Custom-made versions available on request. See pages 150 to 153 for complete sets with fixture elements.



With scales

Order No.	Dimensions	Scale	Long/cross slots	Thread	Weight
281200	400 x 400 x 24	yes	4/4	M 8	10.2
280500	500 x 250 x 24	yes	2/4	M 8	10.5
280800	600 x 300 x 24	yes	3/5	M 8/M 10	12.4
280900	800 x 400 x 24	yes	4/6	M 8/M 10	22.4

Application example



Intermediate plate T-slot 6

Description

Plates with T-slots for mounting on baseplates with T-slots or M6 mounting threads. For X/Y adjustment.

Material

Hard-coated aluminium.



Order No.	No. of slots	Length	Width	Height	Weight
325100	3	117	117	20	0.68

T-Nut 6

T-Nut 6
M 6

Accessories



Handgrip

Description

Grip for mounting in a T-slot to ease transporting the baseplates with T-slots.

Contents

1 set of 2 handgrips with fasteners.



Order No.	Length	Height
328500	150	45

T-Nut 6

Mounting frame with T-slot

Description

Slot rails with T-slot 6, can be joined to form angle constructions or complete frames. With scales for exact and reproducible positioning of fixture elements.

Material

Hard-coated aluminium.



Frame construction as set

Order No.	Description	Length	Width	Height	Weight
281600	Frame construction	500	300	24	3.6
281900	Frame construction	650	410	24	4.3

Individual elements

Order No.	Description	Length	Width	Height	Weight
281730	Cross rail	300	30	24	0.5
281735	Cross rail	350	30	24	0.6
281750	Long rail	500	30	24	0.8
281760	Long rail	600	30	24	1.1
281700	Screw set				0.1

Application example



+ Plate clamping claws with stop

Description

A set of clamping claws for the 24 mm thick dk slot plates. The claws are screwed onto the measuring machine table. Check the table thread sizes before ordering. These elements provide a stop for repeat accuracy while simultaneously securing dk baseplates.



Contents

One set with knurled nuts.

Order No.	For plate thickness	Thread
281406	24	M 6
281408	24	M 8
281410	24	M 10
281412	24	M 12

M ...

Application example

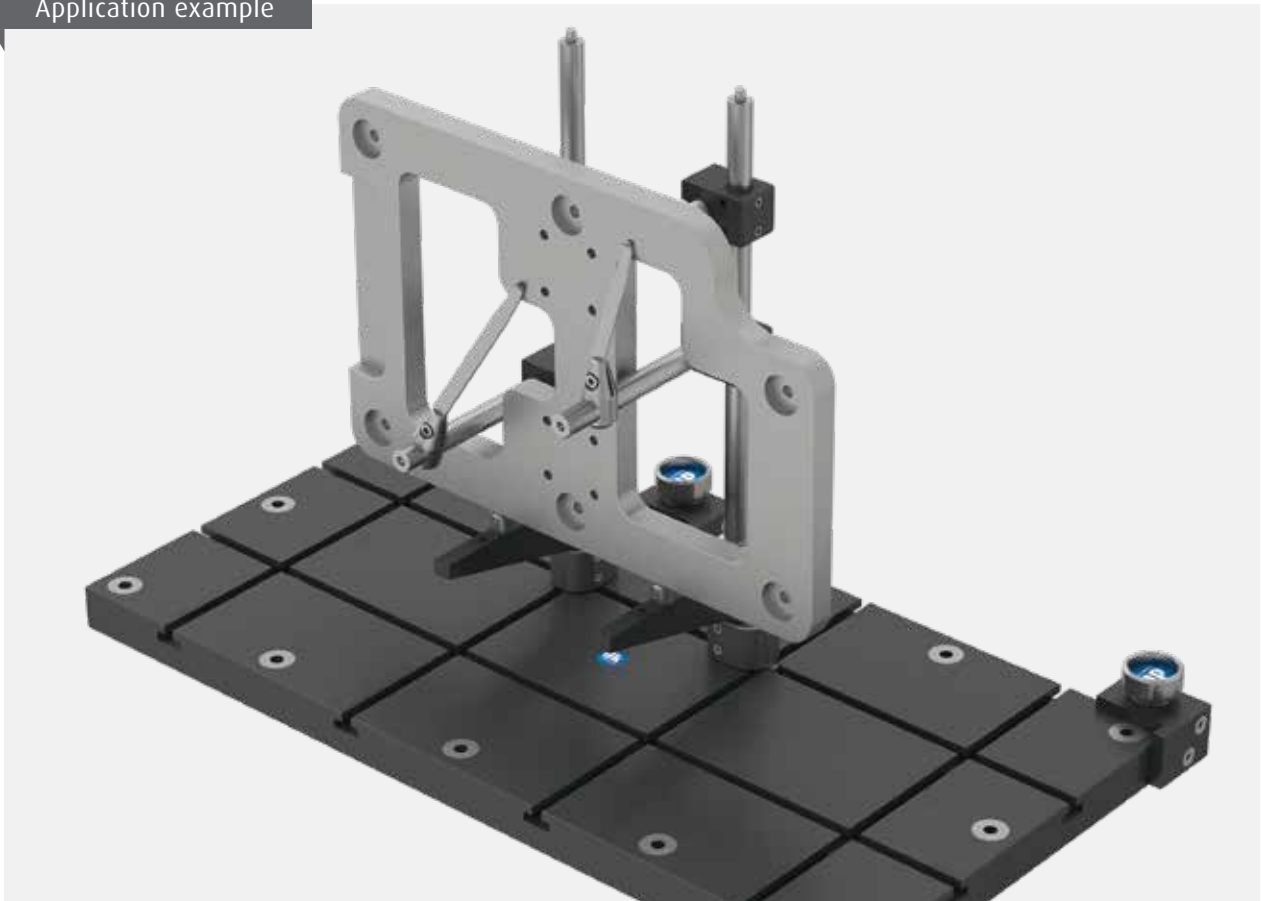

T-slot nuts

Description

M6 T-slot nuts fit in plates and rails with T-slot 6. Used to connect basic rails, columns, SWA 39 quick-action clamps etc. and customer specific structural elements with M6 male threads.

Special sizes for other slot systems available on request.

Material

Stainless steel.

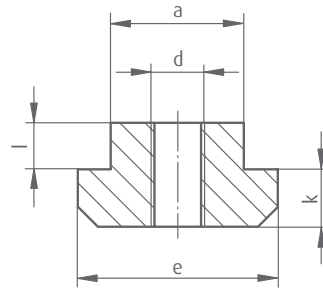

Order No.	d	a	e	k	l
326400	M 6	5.9	16	4.8	4.9

M 6
T-Nut 6

T-slot screws

Description

M6 T-slot screws fit in plates and rails with T-slot 6. Used to connect structural elements with M6 female threads.

Material

Stainless steel.

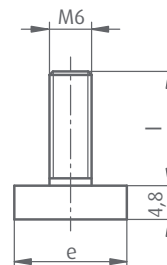

Order No.	e	l	Thread
326800	16	16.2	M 6

M 6
T-Nut 6

Satellite mounts with T-slot key

Description

Mount for M 8 and M 10 modules. With slot key for T-slot 6 for free positioning on a baseplate.

Material

Stainless steel/brass.

Supplied with

T-slot key for T-slot 6.



Order No.	Version
290600	M 8 female thread
290700	M 10 female thread

M 8	M 10
T-Nut 6	T-Nut 6

Application examples



Base rail M 10

Description

Adjustable base rail with slot and M10 connection thread for screwing in columns and articulated arms.

Material

Hard-coated aluminium.

Supplied with

M6 screw for connecting to a T-slot key or nut.
(Order T-slot nut 326400 from page 108 separately)



Order No.	Slot width	Adjustment range	Length	Width	Height
322010	6	60	105	25	12

M 10	M 10
M ...	T-Nut

Application examples



Base rails M 10 XL

Description

Large, highly adjustable base rail with slot and M10 connecting thread for screwing on columns and articulated arms. Includes 4 holes for securing i.e. quick-action clamp 285206 or vices 270860 and 282110 or customer specific elements.

Material

Hard-coated aluminium.



Order No.	Slot width	Adjustment range	Length	Width	Height
397012	12.5	80	150	50	20
397013	12.5	130	200	50	20



+ Fastening accessories

(Order T-slot nut 326400 from page 108 separately)

Order No.	Description	Version
397014	Screw with washer	M 6
397015	Screw with washer	M 8
397016	Screw with washer	M 10
397017	Screw with washer	M 12

Application example

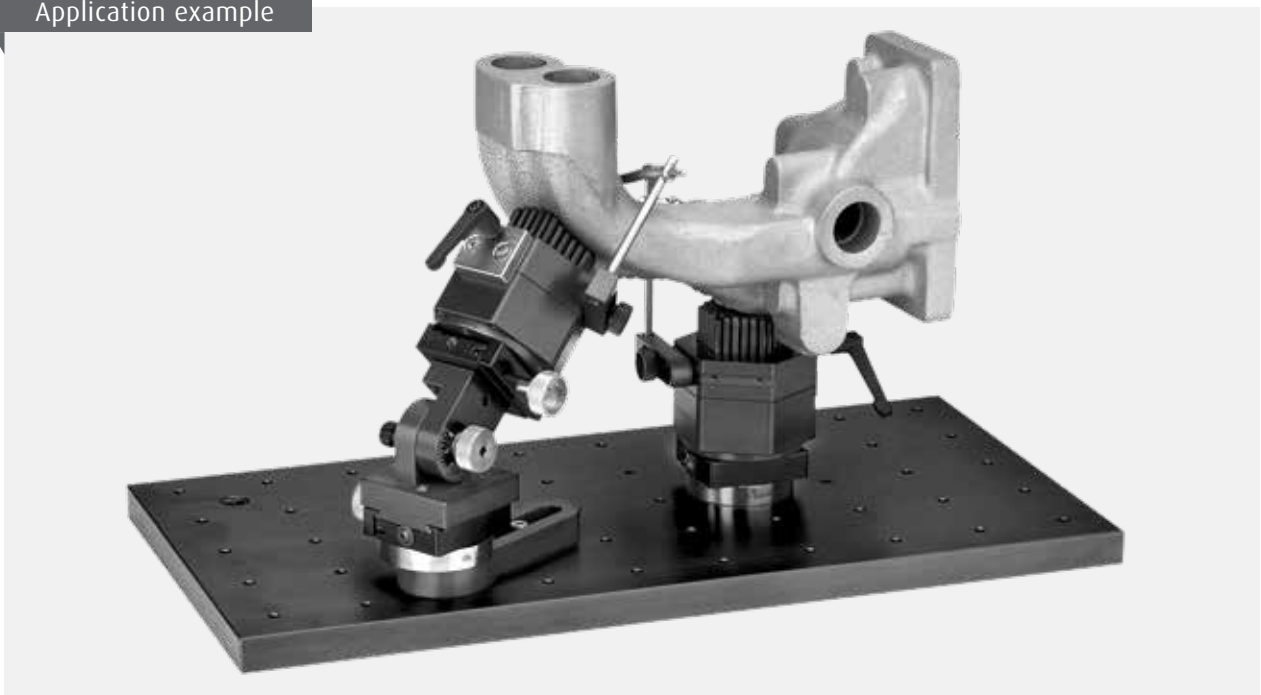

Hexagonal extensions M 10 and M 8

Description

Hexagonal extension pieces with male thread one end and female thread other end. For screwing onto satellite mounts and base rails. Screw together to increase height.

Material

Stainless steel.



Order No.	Male thread	Female thread	Length
304100	M 8	M 8	50
304200	M 8	M 8	100
322200	M 10	M 10	25
322300	M 10	M 10	35
322400	M 10	M 10	50
304400	M 10	M 10	100
253500	M 10	M 10	150



Application example



Self-aligning pads M 10

Description

Support with flattened, swivel ball to compensate for surface irregularities. Can be screwed onto hexagonal extension pieces or directly into base rails.

Material

Stainless steel/black oxidised steel.

Supplied with

Locknut.



Order No.	Support	Swivel range	Adjustment range	Length
323000	Ø 8	± 15°	15	46

M 10

Jack screws M 10

Description

Height adjustable supports for centring and supporting test parts.

Material

Stainless steel.

Supplied with

Locknut.



Order No.	Version	Adjustment range	Length	Fig.
322600	With 90° point, Ø10	15	50	1
322700	With 5 mm ball end	25	63	2

M 10

Quick-change adapter M 10

Description

Quick-change adapter M 10 for SWA 5 / SWA 8 modules.

Material

Stainless steel.

Supplied with

Locknut.



Order No.	Version	Adjustment range	Length
329400	SWA 5	25	55
329500	SWA 8	25	57

SWA 5	SWA 8
M 10	M 10

Accessories

+ Centre points

Description

90° centre points with SWA 8 quick-change mount.

Material

Hard-coated aluminium.

Order No.	Diameter	Height	Fig.
303600	15	20	1
303700	25	20	2
303800	40	24	3

SWA 8



+ Prism supports

Description

120° prism supports with SWA 8 quick-change mount.

Material

Hard-coated aluminium.

Order No.	Clamping range	Prism length	Connection	Height	Fig.
323500	Ø 2-60	8	SWA 8	35	1
323400	Ø 2-60	40	SWA 8	33	2

SWA 8

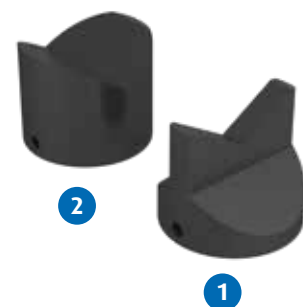

+ Flat supports

Description

Flat supports in various versions: flat face, straight step and prism step. With SWA 8 quick-change mounts.

Material

Hard-coated aluminium.



Order No.	Version	Diameter	Height	Step height	Fig.
303805	Flat face	25	20		1
303810	Straight step	25	20	5	2
303815	Prism step	25	20	5	3

SWA 8

Screw jack set with spring finger

Description

Adjustable base rail with support and spring finger. The support height is adjustable.

Material

Hard-coated aluminium/stainless steel.

Supplied with

Base rail (322010), extension piece (322200), jack screw (322700), adapter plate for columns (353700), column with screw (368300), spring finger (302800), locknut and fastening screw.

↳ See T-slot nuts page 108 for fastening the base rail in a T-slot.



Order No.	Adjustment range	Length	Width	Support height
322005	60	105	25	80-90

M 6

T-Nut

T-slot 6 columns for arm construction, with holder

Description

Column with holder and slot key. Flat side for precise alignment of support arms and bridges relative to the slot directions of the baseplate. Remove the guide pin in the base of the holder for free angular positioning.

Material

Aluminium and stainless steel.

Supplied with

Ø5 mm contact pins and adjustable height rests.



Order No.	Column Ø	Length
288605	12	100
288805	12	150
288905	12	200
289005	12	250
289105	12	300
288650	Column holder with slot key	

Application example

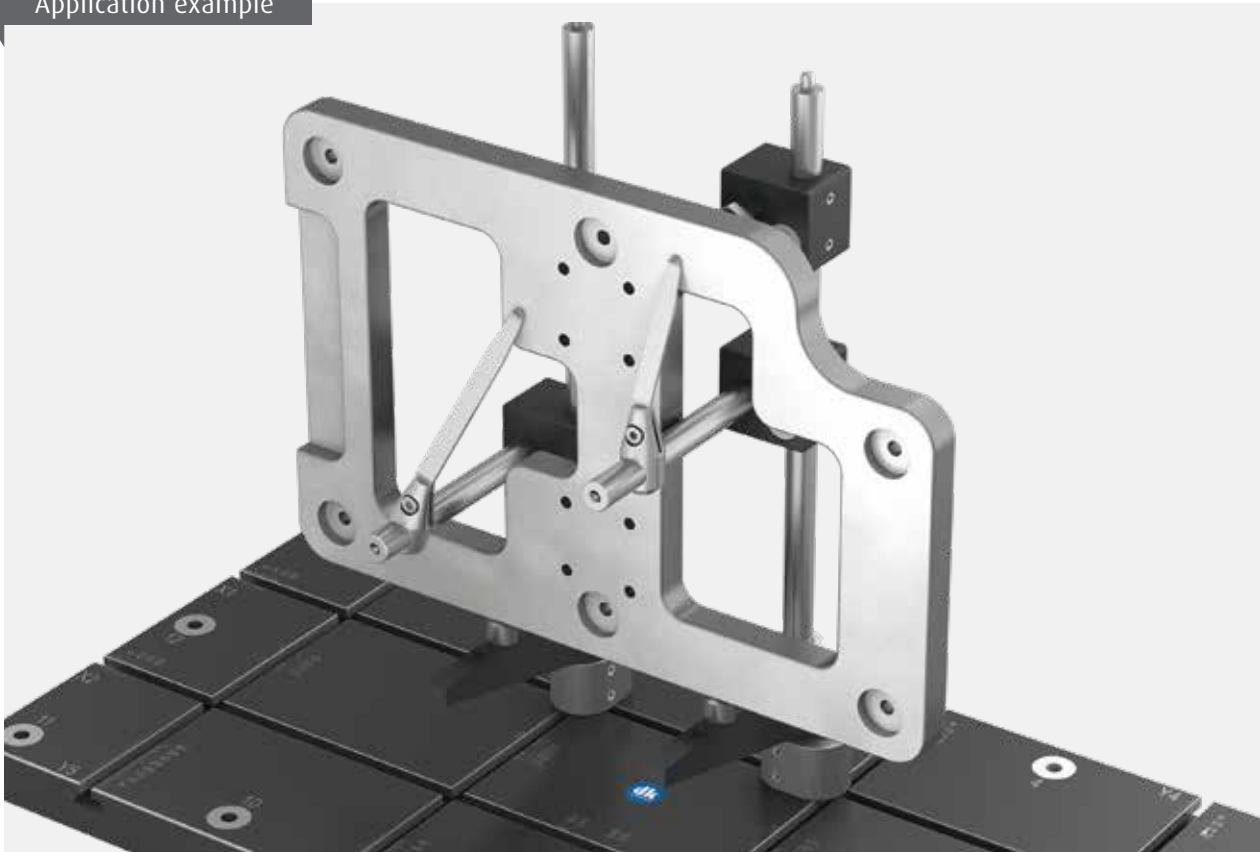

Columns without holder

Description

Column with flat side for precise alignment relative to the slots of the baseplate.

Material

Stainless steel.

Supplied with

Ø5 mm contact pin.

Order No.	Column Ø	Length
352200	12	100
352300	12	150
352400	12	200
352500	12	250
352550	12	300



D 12

Column cross connector D 12 and M 10

Description

Connection element enabling a T-slot 6 column and a column without holder to be fitted together at a 90° angle as an alternative to assembling an M10 support at a 90° angle.

Material

Hard-coated aluminium.



1

Application example



Order No.	Description	Length	Width	Height	Fig.
352150	Connector for Ø12 and M10 columns	38	24	25	1
352110	Cross connector for Ø12 columns	38	24	25	

D 12

Support arm

Description

Support arm for mounting on Ø12 mm columns. With Ø4 mm holes for contact pins and support pins. Arm width 10mm for mounting V-block halves and adjustable supports.

Material

Hard-coated aluminium.

Supplied with

Ø4 mm pin.

See page 121 for V-block halves and supports with slots



1

Order No.	Overhang	Pin holes	Hole spacing	Height	Fig.
286800	60	2	15	20	
286700	100	4	15	30	1
286600	150	6	20	30	

D 12

Application example

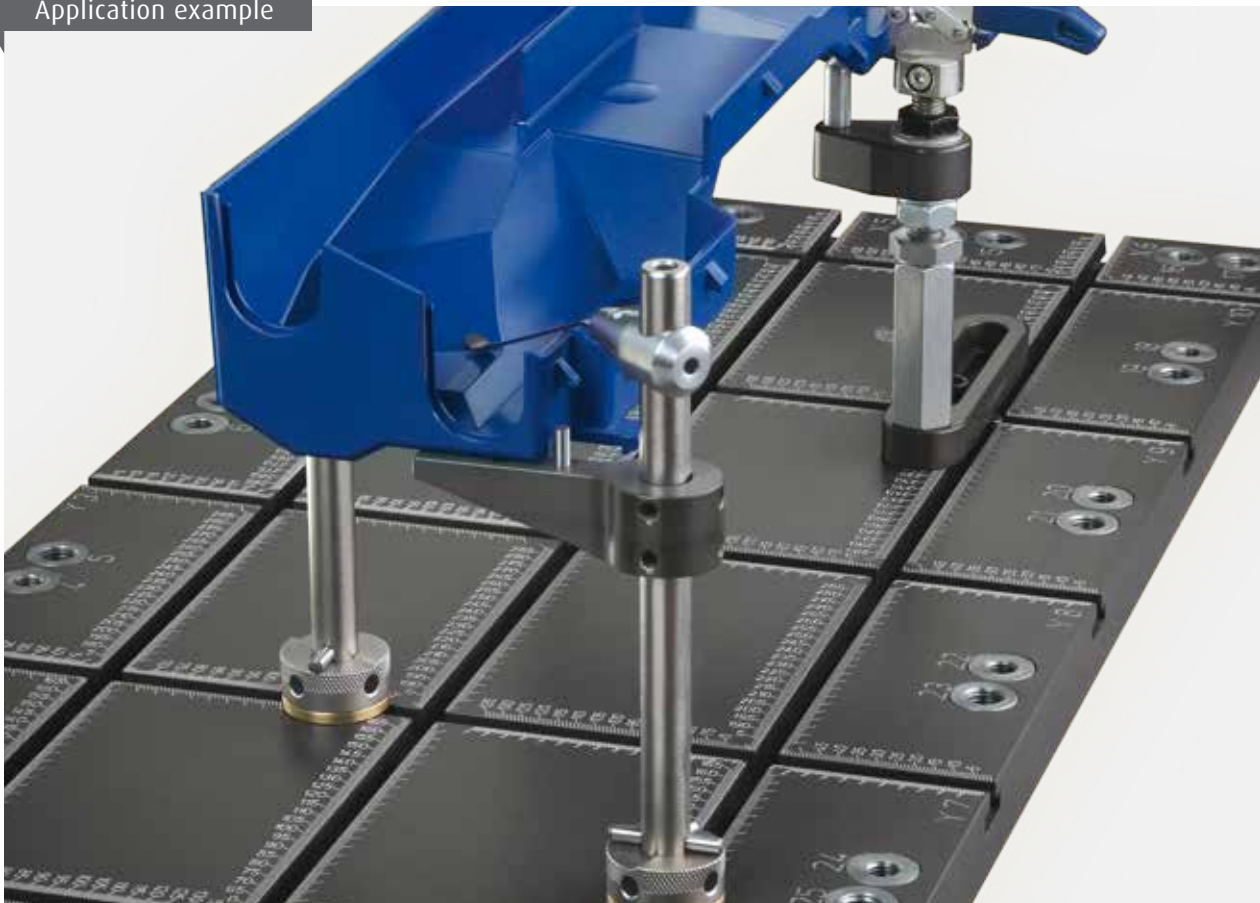

Support pins for support arm

Description

Ball-end and point supports for fitting into arms with $\varnothing 4$ mm holes.

Material

Stainless steel.

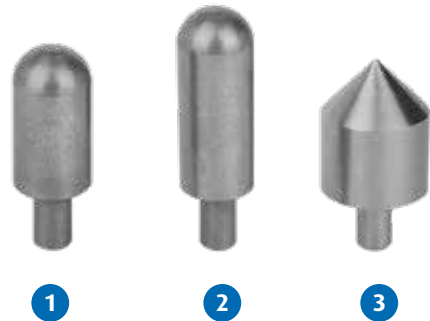

Order No.	Version	Diameter	Fig.
319400	R4 ball-end x 15 mm	8	1
319500	R4 ball-end x 20 mm	8	2
319300	90° point	12	3

Application example

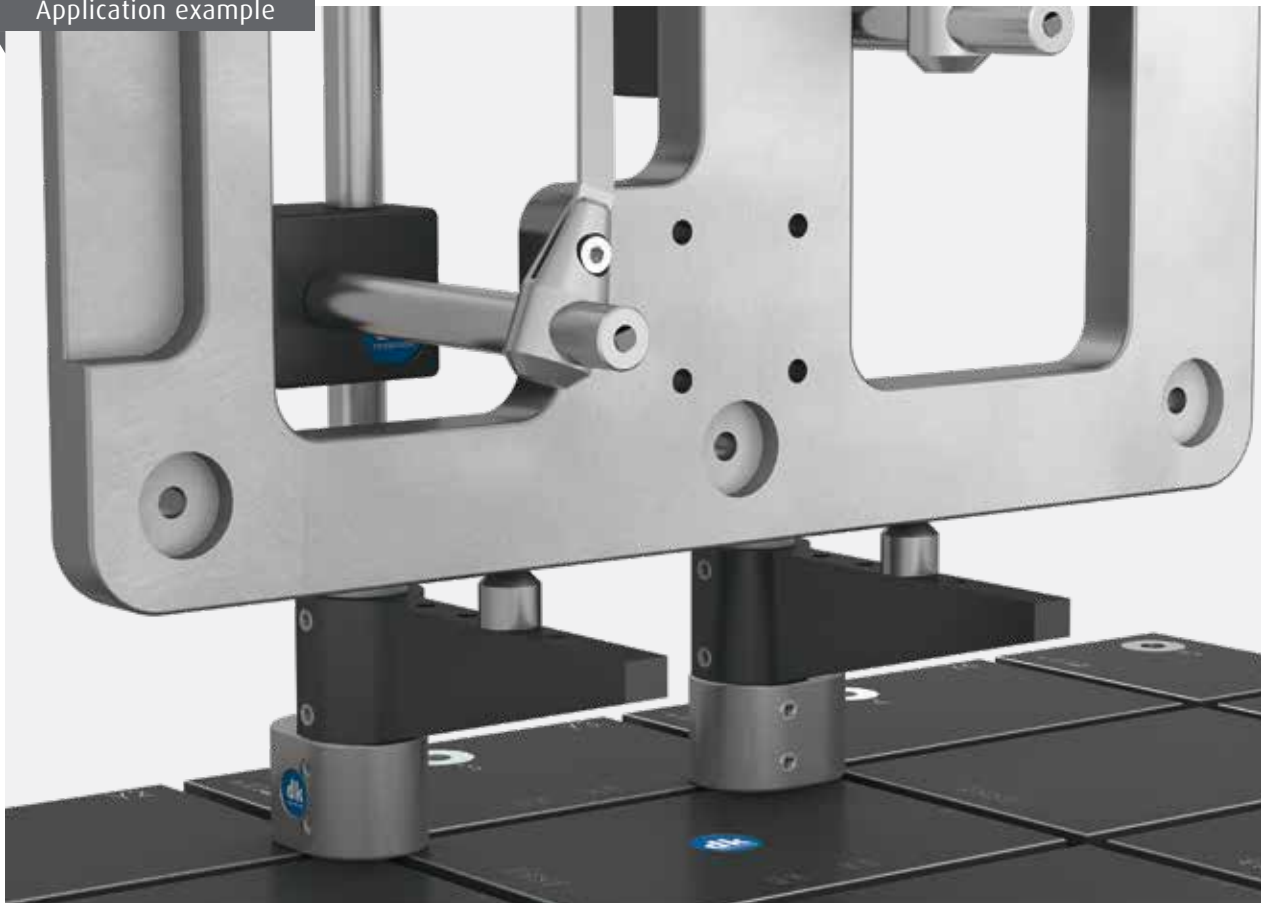

Bridge supports

Description

Bridge support with 10 mm bridge width for mounting on two Ø12 mm support columns. V-block halves and supports with slots can be mounted on the bridge. Laterally adjustable stops can also be mounted (Ø7 mm).

See page 46 stops for vices for adjustable stops.



Order No.	Centre distance	Fig.
287000	90	
287100	125	1

D 12

Application example



Mounts with slot

Description

Adjustable mounts with 10 mm slot for mounting on support arms and bridge supports. For easy adaptation of the SWA 8 quick-change support elements or supports and elements with M 10.

Material

Hard-coated aluminium/stainless steel.

↳ See pages 113 to 115 for accessories.

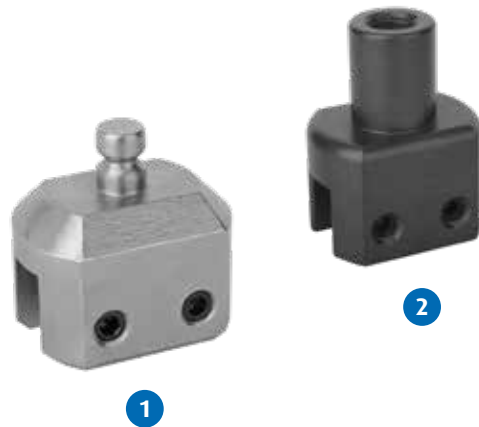

Application example



Order No.	Version	Length	Width	Height	Fig.
303200	SWA 8	25	25	35	1
303300	M 10	25	25	35	2

Pair of V-block halves

Description

Pair of 120° V-block halves with 10 mm slot, mounting on support arms and bridge supports.

Material

Hard-coated aluminium.

Contents

One pair.



Application example



Order No.	V-block width	Total height	Fig.
287210	10	47	
287200	24	27	1

Adjustable stop

Description

Stop for mounting on Ø12 mm columns. Effective length of the stop ca. 130 mm (to centre of column).

Material

Hard-coated aluminium/nickel plated steel.



Order No.	Length	Width	Height
287500	35	30	20

D 12

Application example



Application examples



Extensions for clamping supports

Description

Extension pieces for raising stop and positioning elements. M6 connecting thread.

Material

Hard-coated aluminium.

Supplied with

Slot keys.



Order No.	Height	Fig.
324100	100	1
324600	88-112	2

M 6	M 6
T-Nut 6	M ...

Application example

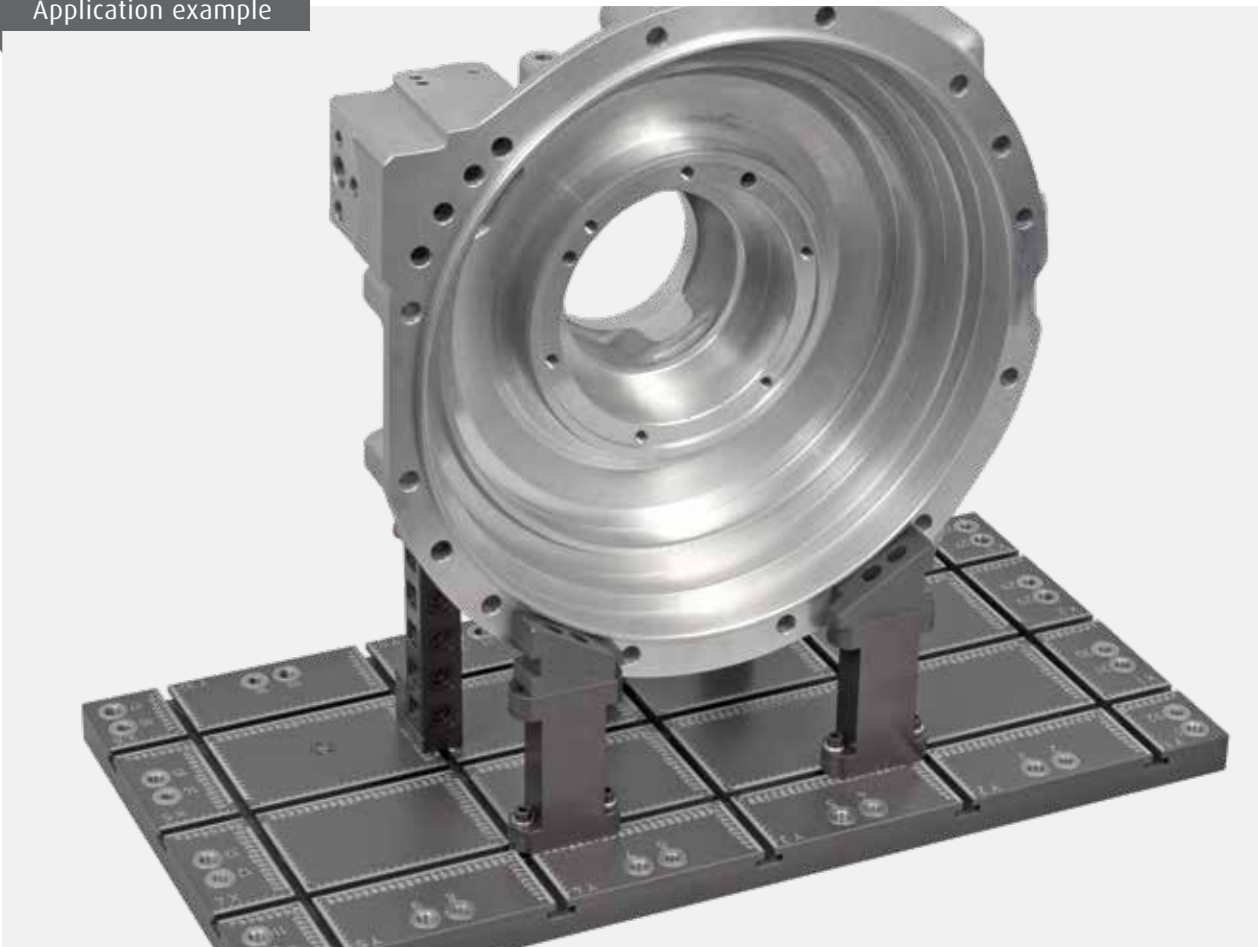

Pair of V-block halves on a T-slot 6

Description

Pairs of V-block halves for T-slots. The clamping range is freely adjustable. With lateral slots and tapped holes for mounting a tensioning strap fixture or spring finger. Part 306500 with mounting hole for stops.

🔗 See pages 43 and 46 suitable for stops.

Material

Hard-coated aluminium/steel.

Supplied with

Screws and T-slot nuts



Order No.	Prism	Block width	Height	Fig.
305500	120°	18	42	1
305700	120°	25	42	
306500	120°	40	60	

T-Nut 6

Side clamp with draw-down jaw

Description

Support with fixed stop and draw-down clamping jaw. For mounting on extensions or with T-slot nuts.

Supplied with

T-slot nuts.



Application example



Order No.	Stop	Adjustment range	Length	Width	Height	Fig.
320500	Straight	2.5	65	25	27	1
320600	Radius	2.5	65	25	27	

M 6

T-Nut 6

Thread reducer

Description

Thread reducer for connecting different thread sizes e.g. columns, extension pieces, articulated arms, supports, satellite mounts etc.

Material

Stainless steel.



Order No.	Male thread	Female thread
275030	M 4	M 8
369000	M 5	M 6
269500	M 5	M 8
275000	M 6	M 8
275010	M 6	M 10
297800	M 8	M 10
275110	M 10	M 6
275100	M 10	M 8
275200	M 12	M 8
275300	M 12	M 10

M ...

Application example

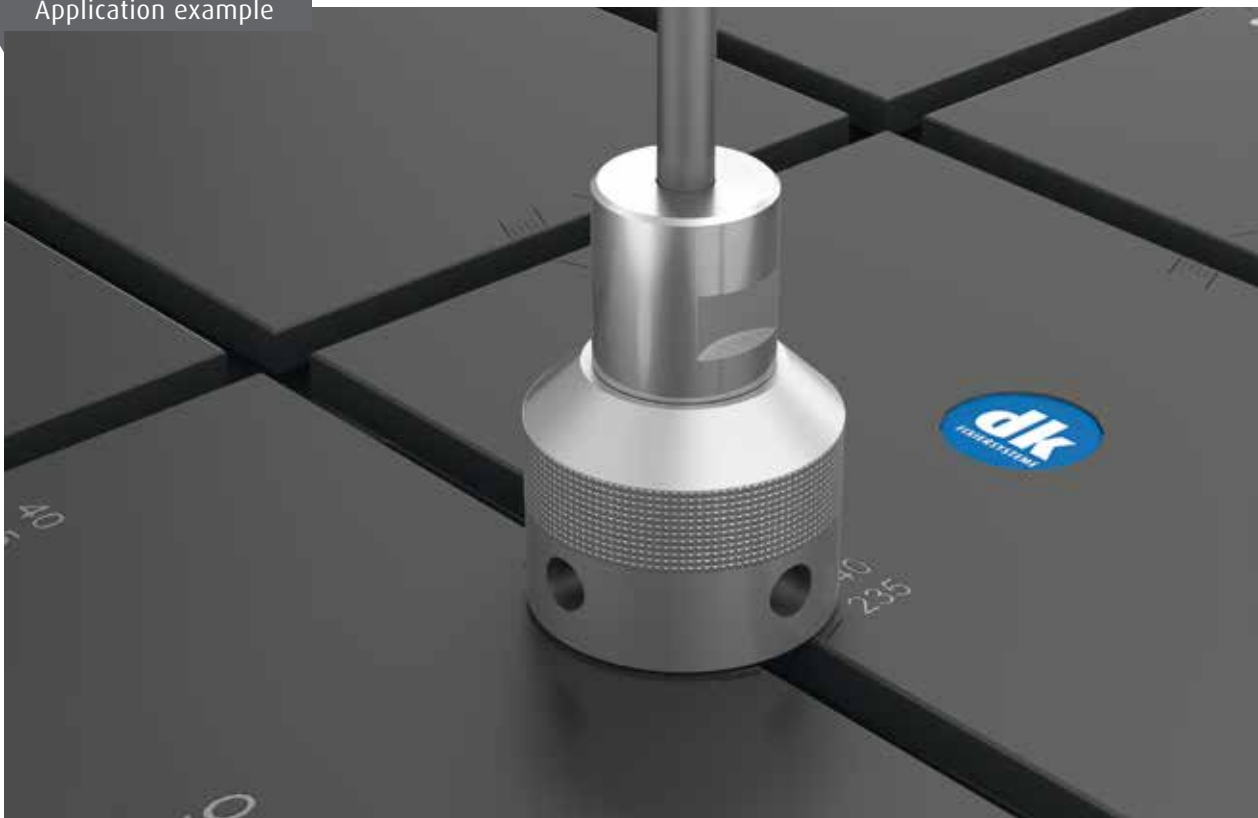

Columns with screw

Description

Columns with screws for mounting spring fingers or for use as a stop element.

Material

Stainless steel.



Application example



Order No.	Column Ø	Thread	Length
269042	4	M 4	30
269043	4	M 4	50
269044	4	M 4	75
368100	6	M 6	30
368120	6	M 8	30
368200	6	M 6	50
368220	6	M 8	50
368300	6	M 6	75
368400	6	M 6	100
368500	6	M 6	125
368505	6	M 6	150
368600	12	M 6	50
368620	12	M 8	50
368700	12	M 6	100
368720	12	M 8	100
368800	12	M 6	150
368820	12	M 8	150
368900	12	M 6	200
368920	12	M 8	200
368610	12	M 10	50
368710	12	M 10	100
368810	12	M 10	150
368910	12	M 10	200

M ...

Articulated arms

Description

Progressive clamping articulated stands with a connection screw in the base and a quick-change adapter on the arm. Mechanical articulated clamping arm. Central locking. Holding force at right angles 100 N (type MU) or 80 N (type SU).

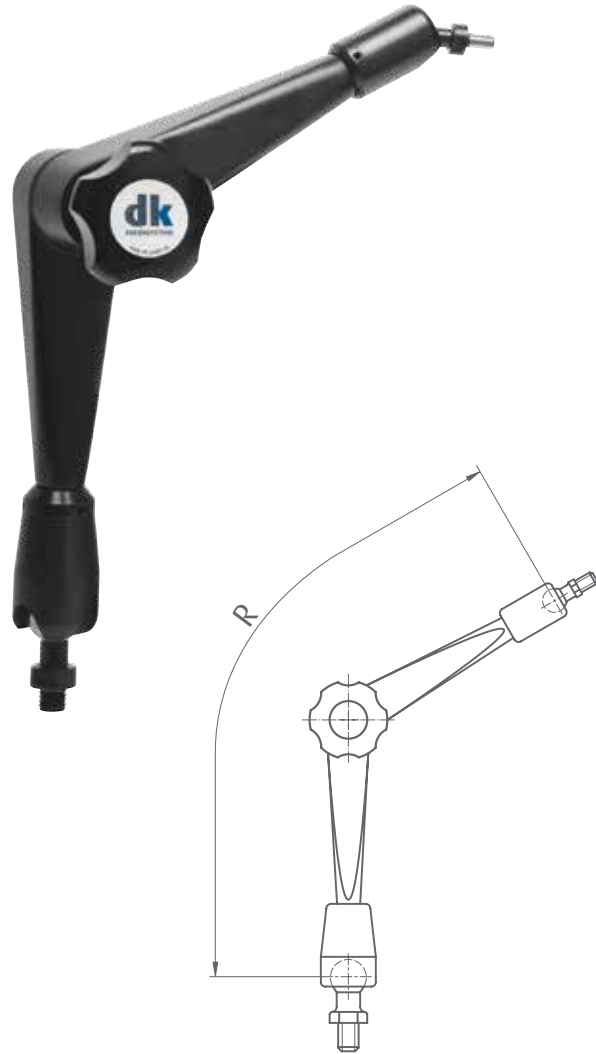

Application example

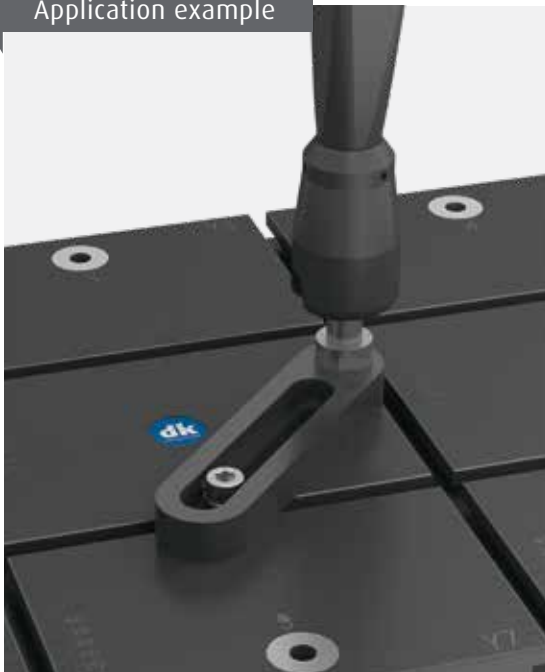

Order No.	Type	Thread	Adapter	Action range (R)
296800	SU	M 8	SWA 5	160
296700	SU	M 8	SWA 8	160
296900	MU	M 10	SWA 5	280
297000	MU	M 10	SWA 8	280



Application examples

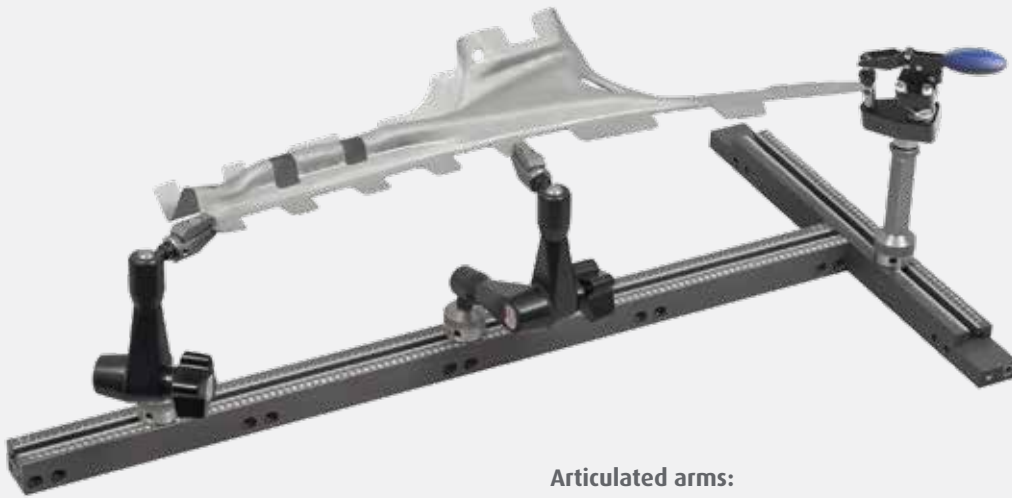

Articulated arms:

- Highest clamping force due to special, patented mechanical clamping principle
- Quick fixation – all rotary movements are locked by one clamping screw
- Comfortable operation through progressive clamping: the arms are locked and released in a defined sequence



Spring fingers

Description

For the simple and quick holding down of workpieces. Self-locking on round columns due to the applied tension by manually pressing down.

Material

Stainless steel.

Application example

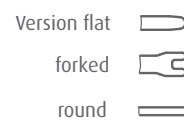
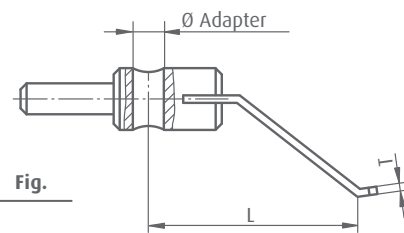
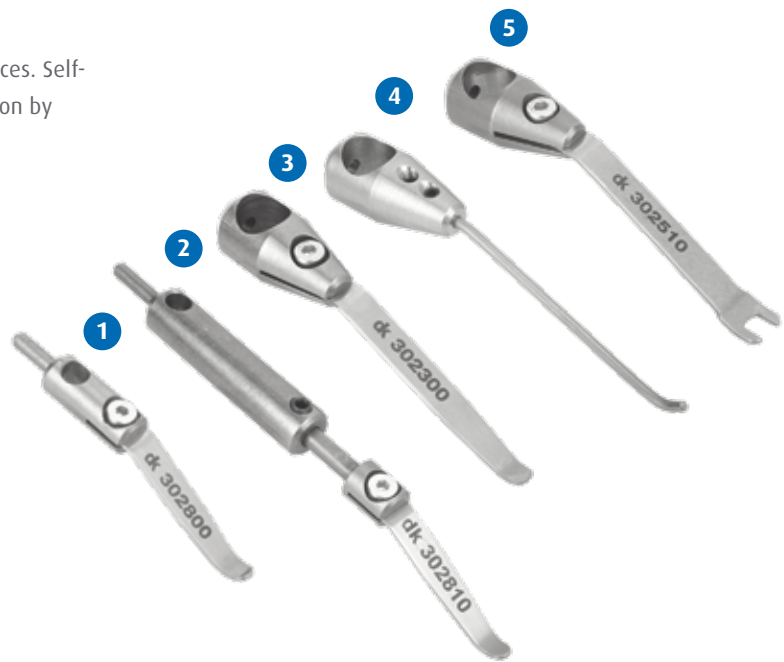
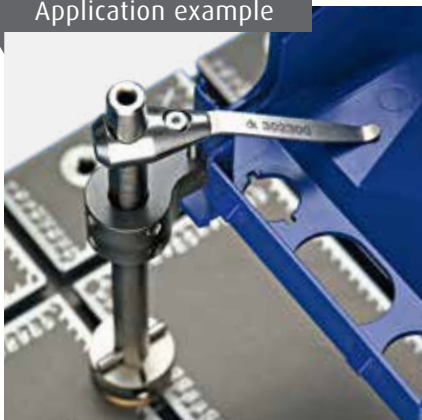

Order No.	Adapter Ø	Version	T	L	Fig.
269037	4	Flat	0.4	30	
343700	4	Flat	0.8	30	
269038	4	Round	1.1	40	
269039	4	Round	1.1	60	
343710	4	Flat	0.8	30	
302750	6	Round	1.1	50	
302760	6	Round	1.5	50	
302800	6	Flat	1	50	1
302900	6	Flat	1	75	
302810	6	Flat	1	90-125	2
302910	6	Flat	1	115-150	
302300	12	Flat	1	75	3
302400	12	Flat	1	95	
302320	12	Flat	1	120-150	
302500	12	Flat	1.5	75	
302600	12	Flat	1.5	95	
302520	12	Flat	1.5	120-150	
302350	12	Round	2.5	80	4
302340	12	Round	3	80	
302510	12	Forked	1.5	75	5
302610	12	Forked	1.5	95	

Columns with screw

Description

Columns with threaded connection for mounting spring fingers or for use as a stop element.

Material

Stainless steel.



Application example



Order No.	Column Ø	Thread	Length
269042	4	M 4	30
269043	4	M 4	50
269044	4	M 4	75
368100	6	M 6	30
368120	6	M 8	30
368200	6	M 6	50
368220	6	M 8	50
368300	6	M 6	75
368400	6	M 6	100
368500	6	M 6	125
368505	6	M 6	150
368600	12	M 6	50
368620	12	M 8	50
368700	12	M 6	100
368720	12	M 8	100
368800	12	M 6	150
368820	12	M 8	150
368900	12	M 6	200
368920	12	M 8	200
368610	12	M 10	50
368710	12	M 10	100
368810	12	M 10	150
368910	12	M 10	200

M ...

Adapter plates for columns

Description

Adapter plates for columns with M6 threads (e.g. for spring fingers) for mounting on M8 and M10 hexagonal extension pieces, self-aligning pads, rest pins and M10 quick-change adapters mounts.

Material

Stainless steel.



Order No.	Hole	Overhang
353700	∅ 10	50
353800	∅ 10	72

Application example



Spring fingers with quick-change adapter

Description

Spring finger with SWA 5 quick-change adapter for connecting to articulated arms.

Material

Stainless steel.

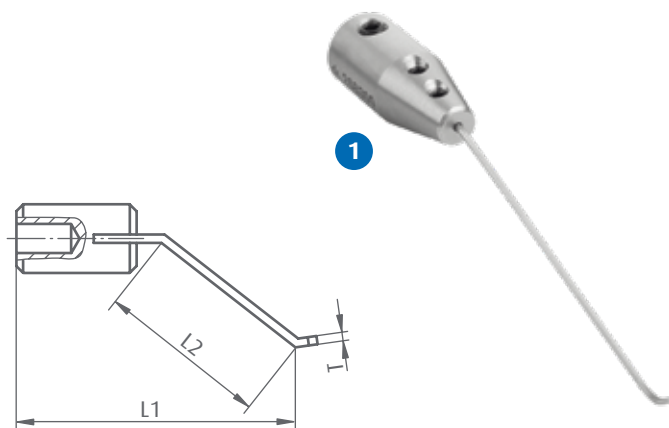

Order No.	Connection	T	L1	L2	Version	Fig.
269300	SWA 5	1.1	55	35	Round	
268300	SWA 5	1.1	70	50	Round	1

SWA 5

SWA 8

Application example

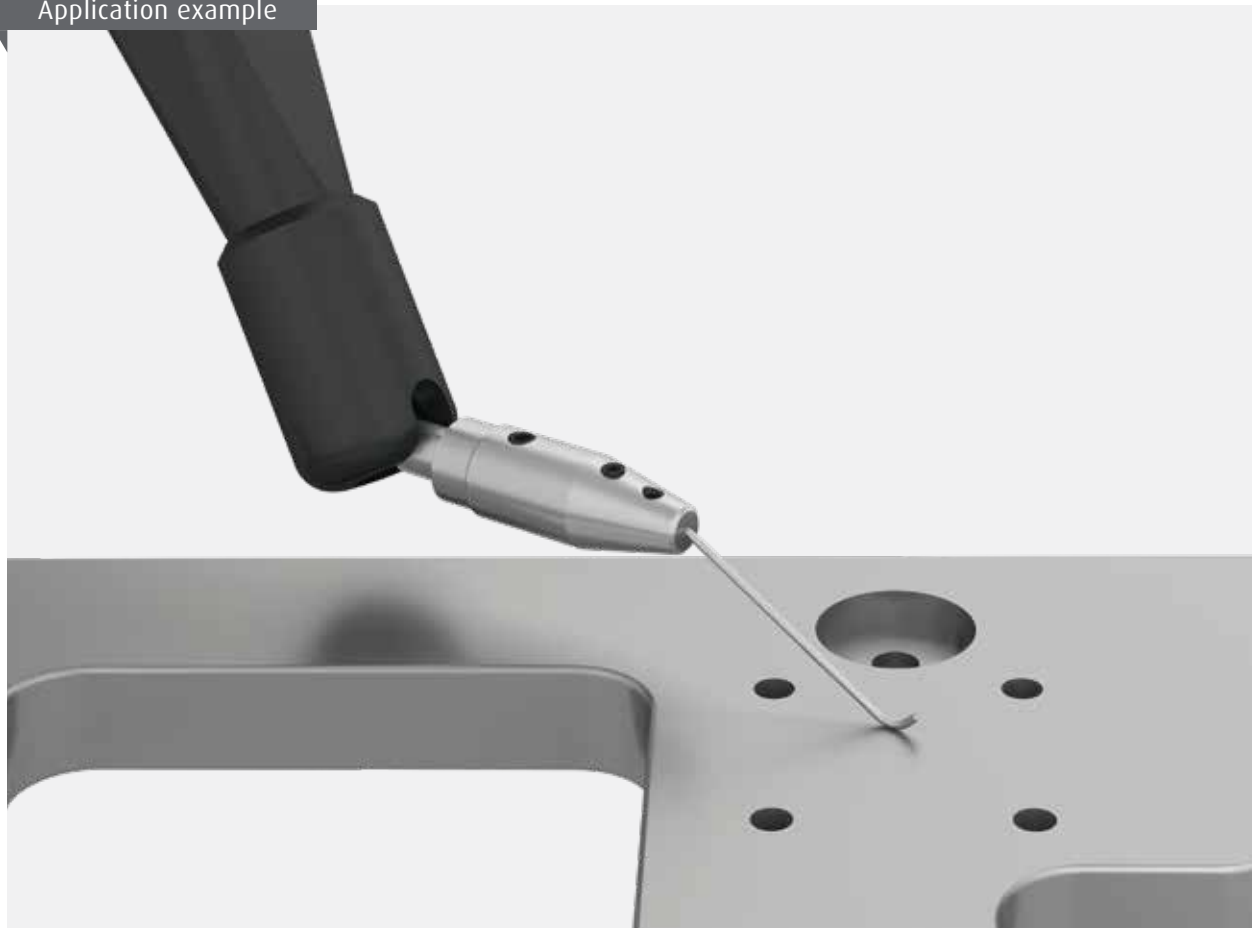

Toggle clamps with support

Description

Toggle clamp with support and M10 thread.

Supplied with

Locknut.



Application example



Order No.	Overhang	Clamping range	Height
336300	32	0-20	100
336400	51	0-27	115

M 10

Application example



Application example

Toggle clamp (used without support) with workpiece...



...and without workpiece



Parallel clamps

Description

Parallel clamps with a maximum clamping range of 75 mm. The jaw blocks have 4 faces and are available in different versions - flat, with a prism for holding round workpieces or convex for holding workpieces that are highly sensitive to bending. The clamps are mounted on SWA 5 or SWA 8 quick-change adapters.

Material

Stainless steel/steel/aluminium.



Application example

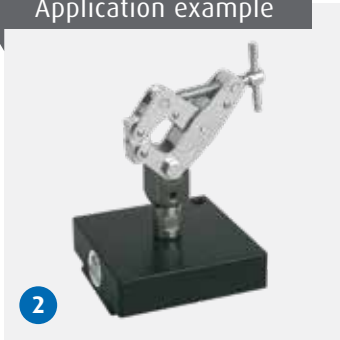

Combined with an SWA 5 quick-change mount on an SWA 29 adapter... or on an articulated arm



Order No.	Clamping range	Connection	Jaw faces	Version	Fig.
278800	0-25	SWA 5	3 flat, 1 long prism	Both jaws rotatable	1
278600	0-25	SWA 5	2 flat, 1 long prism, 1 convex	Both jaws rotatable	1
278400	0-25	SWA 8	3 flat, 1 long prism	Both jaws rotatable	1
334900	0-25	SWA 8	2 flat, 1 long prism, 1 convex	Both jaws rotatable	1
278500	0-25	SWA 39	3 flat, 1 long prism	Both jaws rotatable	2
279610	0-50	SWA 8	3 flat, 1 long prism	Both jaws rotatable	
279620	0-75	SWA 8	3 flat, 1 long prism	Both jaws rotatable	

Parallel clamps with guide pin

Description

Parallel clamp with guide pin fixed in lower jaw to secure the jaws against rotation. Mounted on SWA 5, SWA 8 or SWA 39 quick-change adapters.

Material

Stainless steel/aluminium.

Application example



Order No.	Clamping range	Connection	Version	Fig.
279200	0–25	SWA 5	cross prism in lower jaw	
279210	0–25	SWA 8	cross prism in lower jaw	
279600	0–50	SWA 8	cross prism in lower jaw	1
279300	0–50	SWA 39	cross prism in lower jaw	2

SWA 5

SWA 8

SWA 39

Application example



Tension clamp

Description

Tension clamp for mounting on articulated arms. The tension clamp is designed for use with an articulated arm, the draw hook is pulled out by hand and hooked over a workpiece to provide tension. Connection with SWA 8 quick-change mount.

Material

Stainless steel.



Order No.	Connection	Size	Length	Hook travel	Tensile force (N)
376800	SWA 8	hook shaft Ø10	81	11	80

SWA 8

Prism with spring finger

Description

120° prism on a column with a spring finger. Connection with SWA 8 quick-change mount.

Material

Stainless steel.



Application example

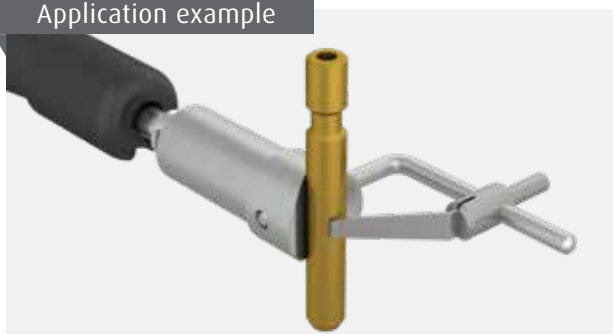

Order No.	Connection	Clamping range	Prism length	Height
285810	SWA 8	Ø 2–25	20	45

SWA 8

Clips

Description

Clip for fixating thin, rigid parts.
Clamping with a ball-head screw. Connection with SWA 5 or SWA 8 quick-change mount.

Material

Steel.



Order No.	Connection	Jaw depth	Clamping width
302100	SWA 5	5	3
302000	SWA 8	5	3

SWA 5 SWA 8

Application examples

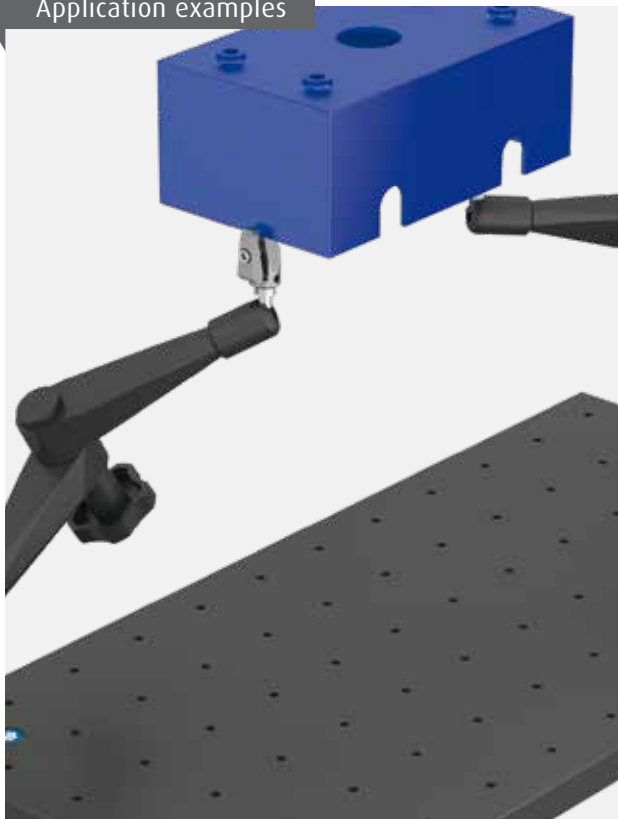

Pairs of V-block halves

Description

V-block halves for T-slot. The clamping range is freely adjustable. With lateral slots and tapped holes for mounting a tensioning strap fixture or spring finger. Part 306500 with mounting hole for stops.

See pages 43 and 46 for suitable stops.

Material

Hard-coated aluminium/steel.

Supplied with

Screws and T-slot nuts.



Order No.	Prism	Prism length	Height	Fig.
305500	120°	18	42	1
305700	120°	25	42	
306500	120°	40	52	

T-slot 6

Application example



+ Spring finger with mount

Description

For quickly and easily holding parts.

Supplied with

Adjustable spring finger (302810), column (368500) and column holder (272910).



Order No.	Clamping range
272940	Ø 40-120 Ø 40-120

↳ See pages 130 and 133 for more spring fingers.

+ Tensioning strap fixture

Description

Ideal for clamping irregularly shaped parts.

Supplied with

M5 fastening screw, operating tools and 5 m tensioning strap.

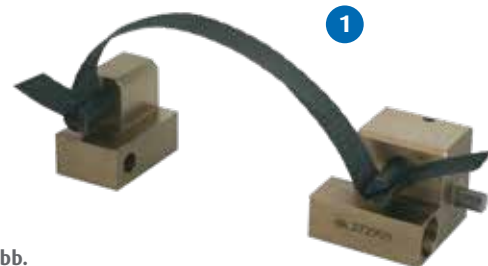

Order No.	Clamping range	Description	Abb.
272900	From Ø 40	Standard	1
272850	From Ø 40	Extra strong	
272855	Adapter for mounting 272850 on T-slots 6		
272902	Adjustable torque wrench		

Tailstocks

Description

Pair of tailstocks with one fixed and one movable centre. The movable centre is spring-loaded and can be locked. For location in a T-slot.

Material

Hard-coated aluminium/steel.

Supplied with

T-slot nuts and $\varnothing 15 / 60^\circ$ centres.



Order No.	Centre height	Length	Width	Height	Weight
306000	50	150	25	75	0.72

T-Nut 6

Application example

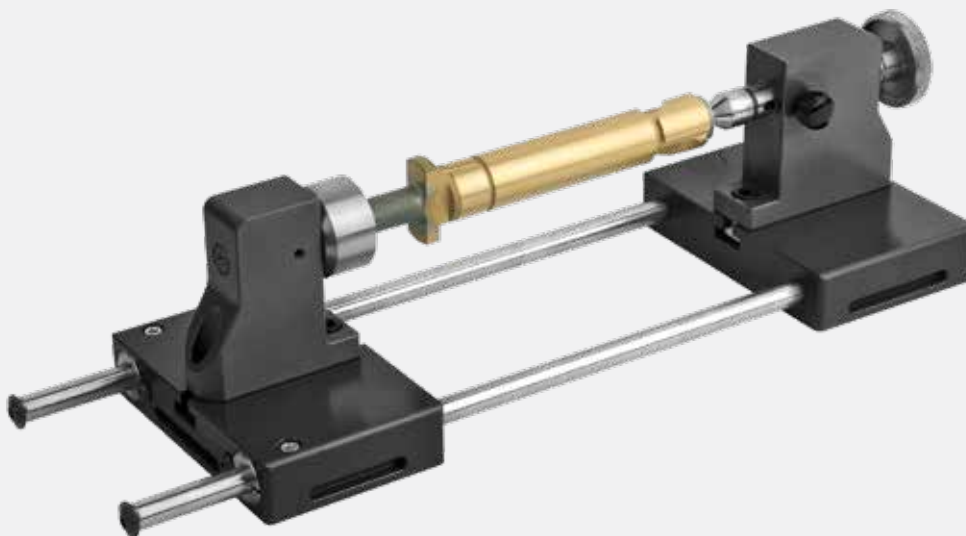

+ Adjustable baseplate

Description

Mounting plate with T-slot (6 mm) for the mounting tailstocks and/or other equipment. Suitable for transmitted light measurements on projectors. Infinitely variable adjustment on guide shafts with lock. Plate can be fixated with claw clamps.

↳ See page 271 for claw clamps.

Material

Hard-coated aluminium/steel.

Extension

0–210 mm.

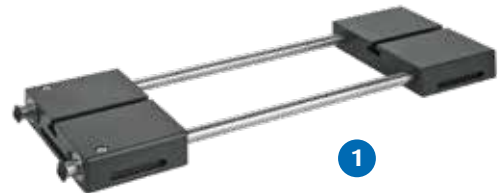

Order No.	Length	Width	Height	Version
262510	370	120	25	1

T-Nut 6

+ Fixed centres

Description

One pair of fixed tailstock centres.

Material

Hardened steel.



Order No.	Centre angle	Diameter
306100	60°	Ø15–30 mm

+ Female centres

Description

Material

Hardened steel.



Order No.	Centre angle	Diameter
306320	90°	Ø3–15 mm
306325	90°	Ø15–30 mm

Suction cups

Description

Suction units with removable support pin.

Material

Silicone/brass.

↪ See page 145 for suitable suction cup adapters.



Order No.	Cup Ø	Connection thread
295800	12	M 5
295900	18	M 5
296000	25	1/8
296100	34	1/8

Application example

- 1 Round T-slot baseplate (page 104)
- 2 Satellite mount with T-slot nut (page 109)
- 3 Articulated arms (page 128)
- 4 Suction cups (page 144)
- 5 Vacuum distributor (page 145)
- 6 Spiral hose (page 145)

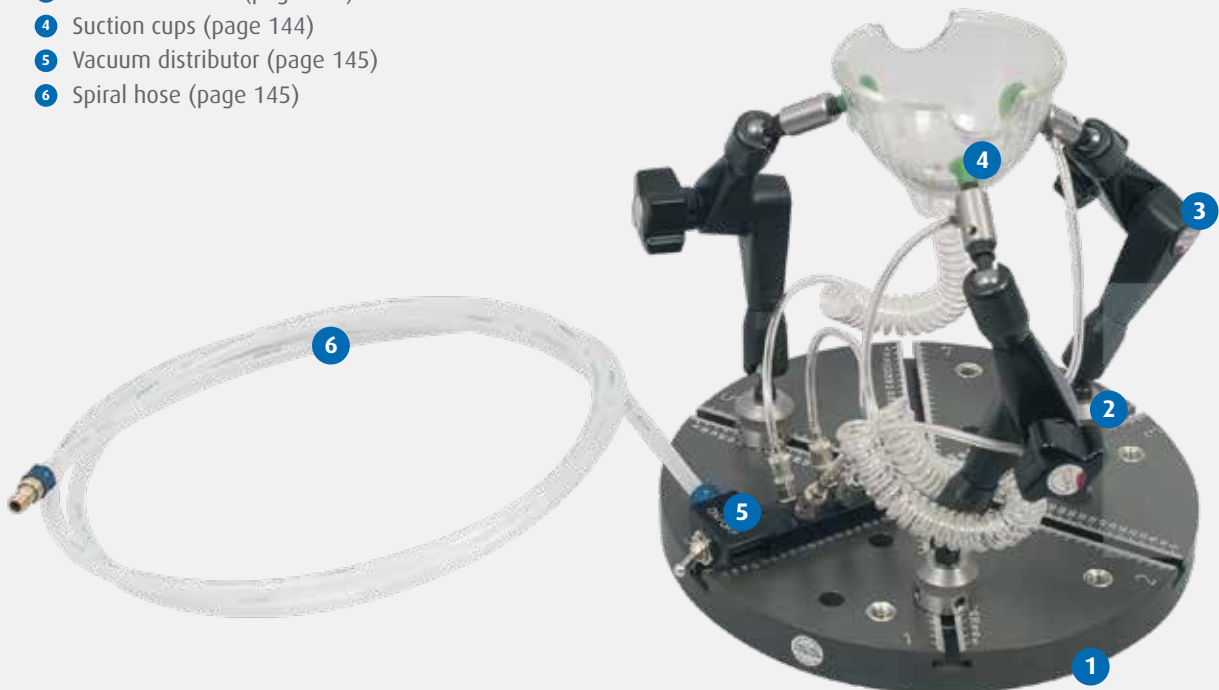

+ Spiral hose

Description

Transparent spiral hose with quick lock (D 5) and M5 connection thread.

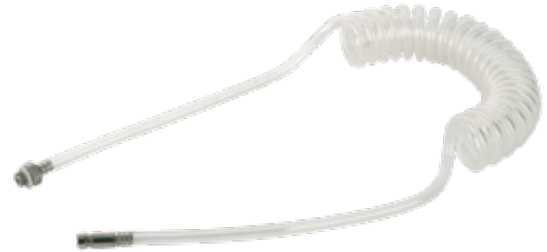

Order No.	Length (relaxed)	Length max.	ID
293600	350	1000	2

+ Vacuum distributor

Description

Multi-port vacuum distributor with quick lock couplings (D 5) and 1/8" connection line to vacuum pump. ON/OFF switch with rapid air vent.

Material

Aluminium/steel.



Order No.	No. of ports	Supplied with
293800	6	Connection line

T-Nut 6

+ Suction cup adapter

Description

SWA 5 mount for suction cups. Connection for M5 spiral hose.

Material

Steel/stainless steel.



Order No.	Version
292700	For cups with M 5 mount
292800	For cups with 1/8" mount

SWA 5

Vacuum pumps

Description

Dry-running rotary-vane vacuum pumps. Absolutely oil-free. Mains voltage 220–240 V. Mounted on rubber vibration-damping elements, with ON/OFF switch in power cable and 1/8" port for connecting vacuum outlet.

Order No.	Nom. suction capacity	Final pressure	Nom. motor power	Noise level
298510	4.1 m ³ /h	150 mbar	0.18 kW	58 dB (A)
298610	8.0 m ³ /h	150 mbar	0.31 kW	58 dB (A)

Vacuum pumps for compressed air operation

Description

Compressed air powered vacuum pump with connection hose and ON/OFF switch.

Material

Aluminium.



Order No.	Nom. suction capacity	Operating pressure	Air consumption
298700	7.4 m ³ /h	5 bar	30 l / min

+ Four-way hexagon key

Description

Practical and compact cross design with 3 key sizes per tool. Covers all hexagon socket sizes used in the Spannfix and Schienenfix ranges.

Material

Steel/stainless steel.

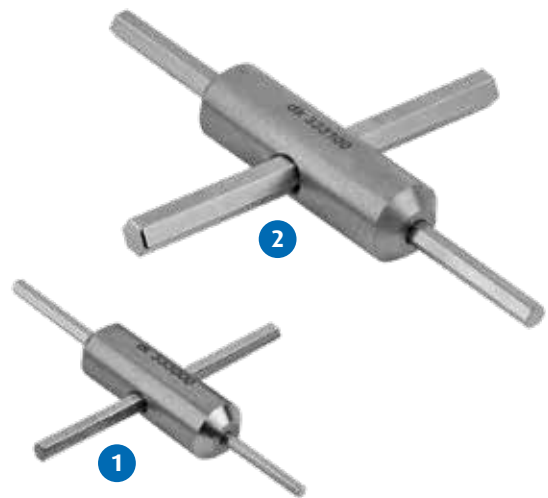

Order No.	Size	Fig.
333000	2 / 2.5 / 3	1
333100	4 / 5 / 6	2

Quick-action clamp for T-slot

Description

SWA 39 quick-action clamp for direct fastening on T-slot plates. Mounted on a 12 mm high intermediate plate.

Material

Hard-coated aluminium/stainless steel.

Supplied with

T-slot nut and fastening screw.



Order No.	Height
285300	23.5

SWA 39
T-Nut 6



Information

The quick-action clamp for T-slot 6 from the SPANNFIX system opens up the entire world of the dk modular system with all manner of structural, adjustment and clamping elements that we present in the SWA 39 range from page 16.

Take a look at the product video on our home page. Simply scan the QR code or click the link below to watch now:

 www.dk-fixiersysteme.de/technology/modular_system

Application examples



The SWA39 elements can form a support in the context of the fixation of large parts, for example by means of the flexibly adjustable negative form program NADELFIX.

Especially in combination with standard clamping elements such as vice and chucks, the system offers a rapid and extremely flexible, exactly reproducible positioning of clamping elements by means of the quick-action clamping clamp for T-slot 6.

The result is a zero-point clamping setup for workpieces which can be dismantled and identically reassembled.

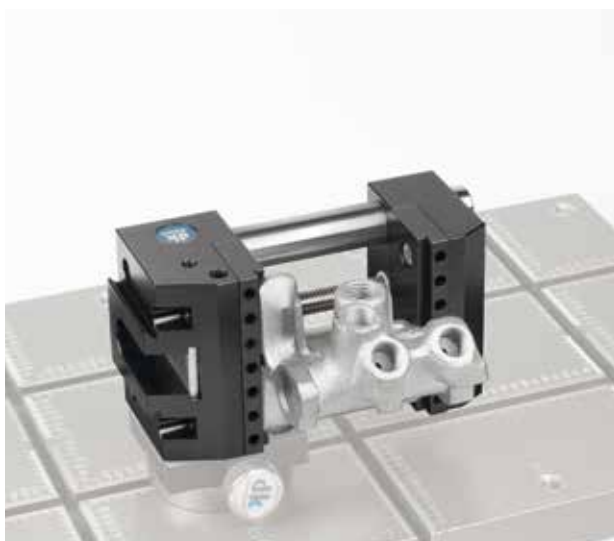

SPANNFIX PRO basic set

Description

Set with supports, extension pieces and stops. A baseplate with T-slots and mounting holes provides the basis. Available in sizes 500 x 250 mm or 600 x 300 mm.

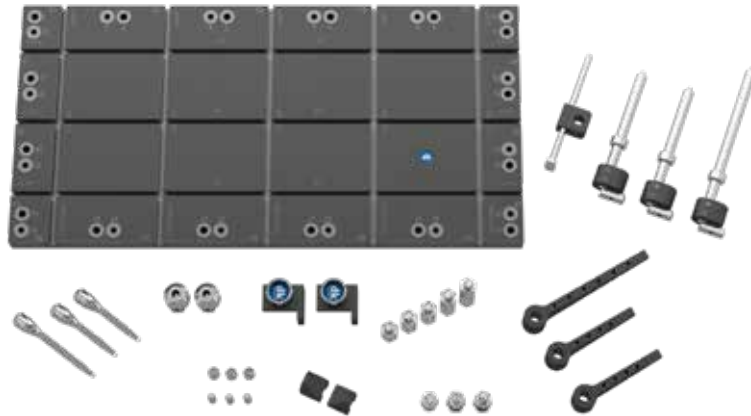

Ordering information

When ordering, let us know the thread or T-slot size on your measuring equipment.

Set versions

Order No.	Description
399710	Spannfix PRO basic set "3"
399720	Spannfix PRO basic set "4"

Set contents

Order No.	Description	Set "3"	Set "4"
280500	Baseplate with T-slot, 500 x 250 mm	1	
280800	Baseplate with T-slot, 600 x 300 mm		1
see right	Claw clamps for Spannfix baseplates Order numbers 281406, 281408, 281410, 281412 for fastening in M6, M8, M10 or M12	1	1
290700	Satellite mount M 10	2	2
322200	25 mm extension	1	1
322300	35 mm extension	2	2
322400	50 mm extension	1	1
322500	60 mm extension	1	1
288805	150 mm columns with T-slot nuts	2	2
288905	200 mm columns with T-slot nuts	1	1
286700	100 mm arm	2	2
286600	150 mm arm	1	1
319300	Support pins with 90° point	3	3
319400	R4 x 20 mm support pins	3	3
287200	Pair of V-blocks	1	1
287500	Adjustable stop	1	1
323000	Self-aligning pads	1	1
322600	Jack screws with cone point	1	1
322700	Jack screws with ball-end	1	1
302300	75 mm spring finger	2	2
302400	95 mm spring finger	1	1

SPANNFIX PRO expansion set

Description

Expansion set with diverse support and clamping modules for the reproducible fixation of test parts.



Set versions

Order No.	Description
399730	Spannfix PRO expansion set

Set contents

Order No.	Description	Quantity
325100	Intermediate plate	1
297000	MU/SWA 8 articulated arm	1
322010	Base rails	2
326400	T-slot nuts	2
322200	25 mm extension	2
322300	35 mm extension	2
322400	50 mm extension	2
288805	150 mm columns with T-slot nuts	2
288905	200 mm columns with T-slot nuts	2
286700	100 mm arm	2
286600	150 mm arm	1
287200	Pair of V-blocks	1
303200	SWA 8 adapter for arm	1
303300	M 10 adapter for arm	1
322700	Jack screws with ball-end	2
329500	Quick-change mounts	2
303600	Ø15 mm centre for quick-change mount	1
303700	Ø25 mm centre for quick-change mount	1
303800	Ø40 mm centre for quick-change mount	1
323500	8 mm prism support for quick-change mount	1
323400	40 mm prism support for quick-change mount	1
302300	75 mm spring finger	2
302400	95 mm spring finger	1
368710	100 mm columns	2
368810	150 mm columns	2
368910	200 mm columns	2
278400	Parallel clamp	1
279600	Parallel clamp with guide pin	1

SPANNFIX PRO complete set

Description

Set that includes articulated arms and parallel clamps for quick and flexible positioning of various test parts. Structural and clamping elements are mounted onto a 600 mm x 300 mm Spannfix baseplate. Various support and clamping modules can be used to achieve reproducible fixation. The high locking forces possible on the articulated arms enable even heavy parts to be held securely.

Ordering information

When ordering, let us know the thread or T-slot size on your measuring equipment.

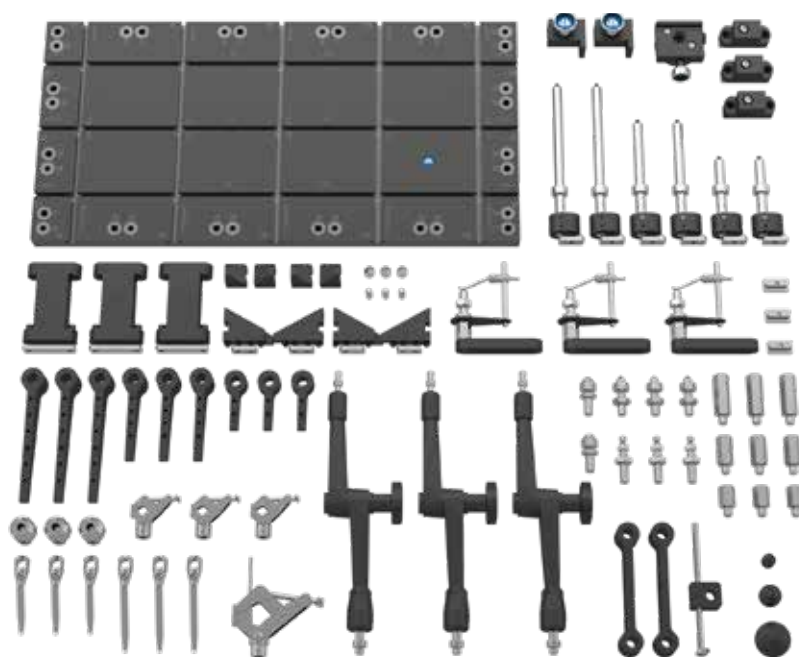

Set versions

Order No.	Description
399700	Spannfix PRO complete set

Set contents

Order No.	Description	Quantity
280800	600 x 300 mm baseplate with T-slots	1
288605	100 mm columns	2
288805	150 mm columns with T-slot nuts	3
288905	200 mm columns with T-slot nuts	2
see right	Claw clamps for Spannfix baseplates Order numbers 281406, 281408, 281410, 281412 for fastening in M6, M8, M10 or M12	1
285300	Quick-action clamp for T-slot	1
320500	Side clamp with draw-down jaw	3
305500	Pair of V-block halves	2
324100	100 mm extension pieces	3
286700	100 mm arm	3

Set contents

Order No.	Description	Quantity
286600	150 mm arm	3
286800	60 mm arm for column	3
287200	Pairs of V-block halves	2
322005	Screw jack set with spring finger	3
326400	T-slot nuts	3
322200	25 mm extension	3
322300	35 mm extension	3
322400	50 mm extension	3
322600	Jack screws with cone point	3
329500	M 10/SWA 8 quick-change mount	3
323000	M 10 self-aligning pads	2
287500	Adjustable stop	1
287100	Bridge support, centre distance 125 mm	2
302500	75 mm spring finger	3
302600	95 mm spring finger	3
29700	MU/SWA 8 articulated arm	3
290700	M 10 satellite mounts	3
279600	Parallel clamp with guide pin	1
278400	Parallel clamps	3
303600	15 mm centre	1
303700	25 mm centre	1
303800	40 mm centre	1
319500	R4 x 20 mm support pins	3
319300	Support pins with 90° point	3

Application example

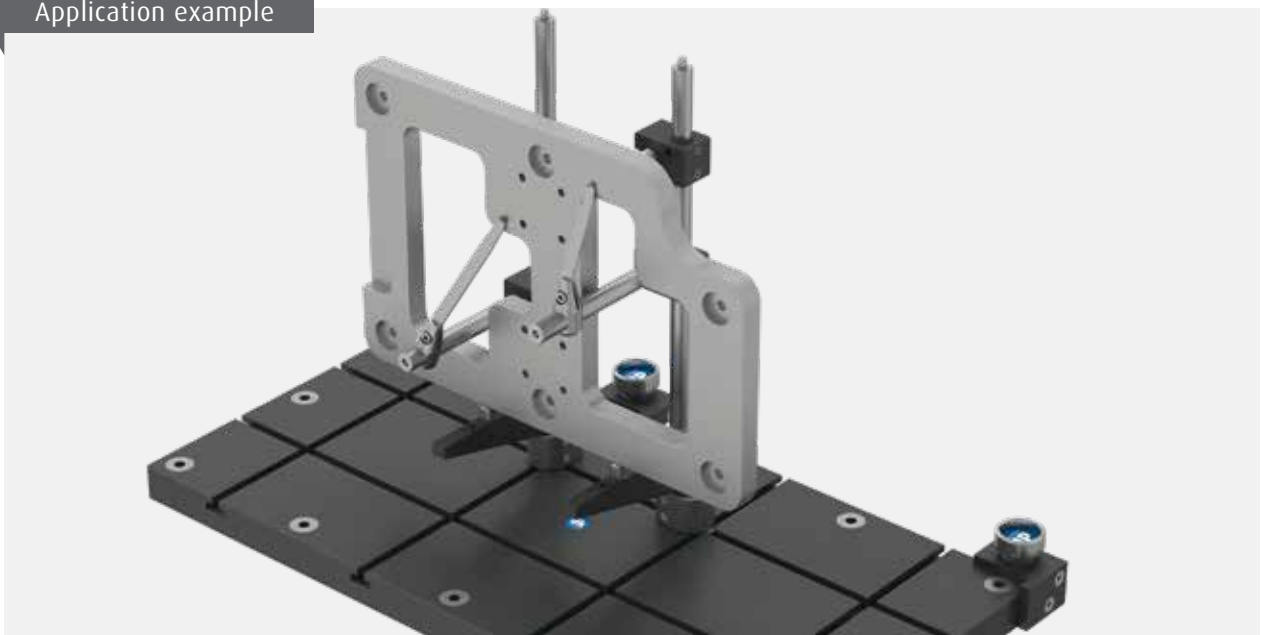

SPANNFIX ECO

Modular clamping elements for tactile measuring

- » The basics are the baseplates or quick-change mounts
- » Economical solution with grid hole system
- » Wide range of structural and clamping elements
- » Flexible clamping solutions diverse workpiece geometries
- » Quick and easy assembly
- » For tactile measuring machines

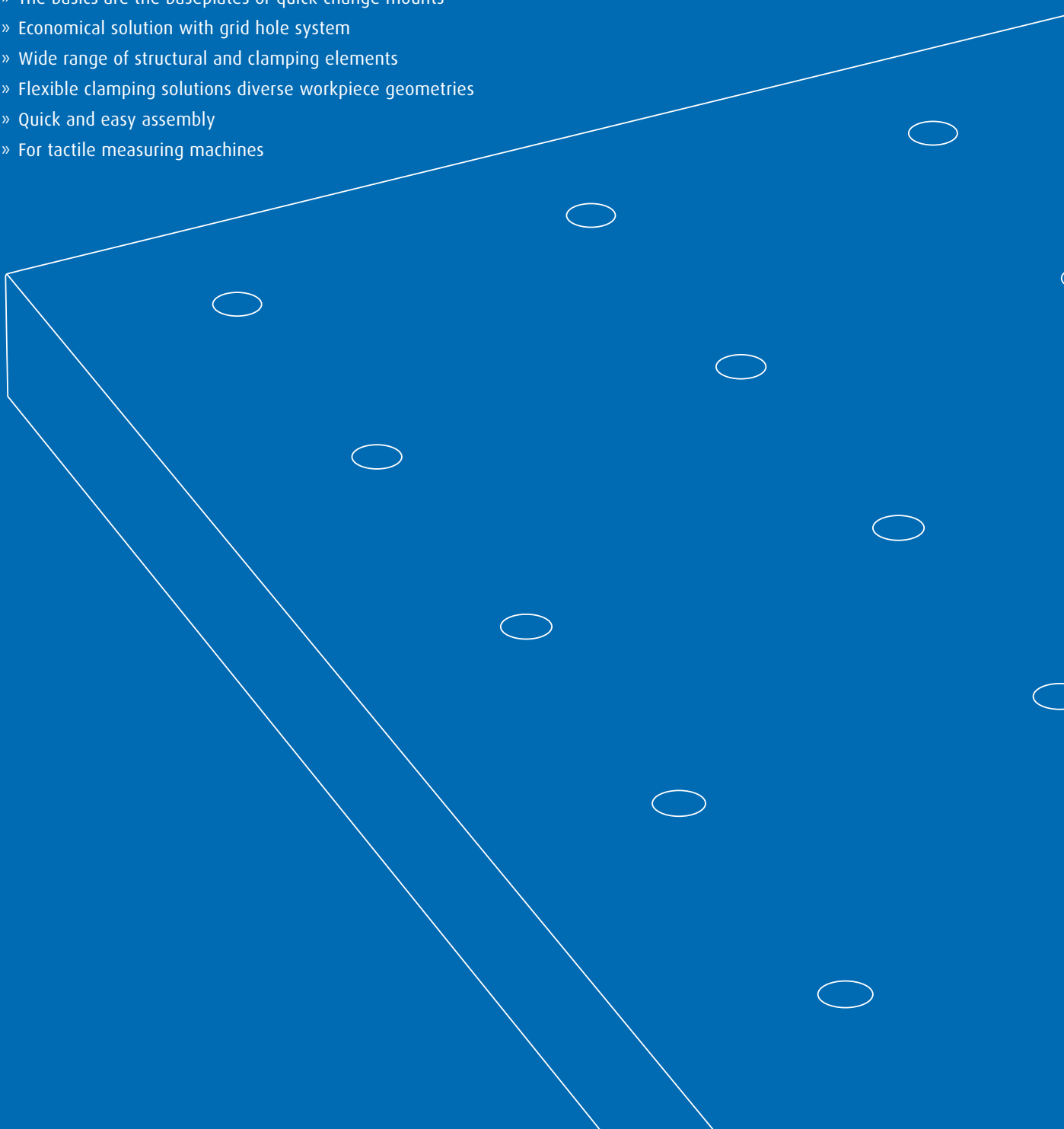

Basic elements
+ accessories



Baseplate with tapped holes

Page 158



Intermediate plates

Page 159



Structural elements
+ accessories



Base rail M 10

Page 161



M 10 XL base rail

Page 162



Hexagonal extensions M 8 and M 10

Page 163



Self-aligning pads M 10

Page 164



Jack screws M 10

Page 164



Quick-change adapter M 10

Page 165



Screw jack set with spring finger

Page 166



Adjustable stop

Page 167



Thread reducer

Page 168



Columns with screw

Page 169



Articulated arms

Page 170

Clamping elements
+ accessories



Spring fingers

Page 172



Columns with screw

Page 173



Adapter plates for columns

Page 174



Spring finger with quick-change adapter

Page 175



Toggle clamps with support

Page 176



Parallel clamps

Page 178



Parallel clamps with guide pin

Page 179



Tension clamp

Page 180



Prism with spring finger

Page 180



Clips

Page 181



SWA 39 connections



Quick-action clamp with fastening screw

Page 182

Sets



Spannfix ECO basic set

Page 184

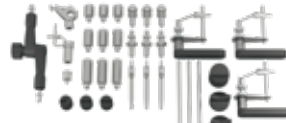

Spannfix ECO expansion set

Page 185

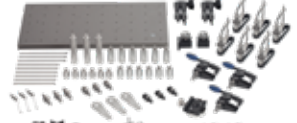

Spannfix ECO complete set

Page 186

Reproducible fixtures through grid holes and base rails

The SPANNFIX ECO is the simpler, more economical alternative to the PRO version with fewer and simplified modules on a baseplate with tapped holes in a standard 50 mm grid. The base rails enable any X/Y position can be easily achieved. Because there are no lateral or angular scales as by the PRO version, repeat constructions of exactly the same fixture are more difficult, but are still possible.

Basic elements

- 1 Baseplate with tapped holes (page 158)



Intermediate plates and accessories (pages 159-160)



Structural elements

- 2 M 10 XL base rail (pages 161-162)



2 + 3 + 4 or 2 + 3 + 3 + 5 + 6 + 7 also available as screw jack set with spring finger (page 166).



- 3 M8 or M10 hexagonal extensions (page 163)



- 4 Screw jacks (page 164)
Other accessories (pages 164-166)





Clamping elements

- 5 Adapter plate for columns (page 174)



- 6 Columns with screw (page 173)



- 7 Spring fingers (page 172)



FAST REASSEMBLY LIFELONG

The basic principle of all dk fixating systems. The compatibility of the dk programs makes the utility value perfect.

The wider range of additional elements included in the PRO system can also be used directly, or with adapters together with the *SPANNFIX ECO* elements shown here. Overall, a much better and quicker solution for the safe and repeatable fixation of test pieces than specially designed and manufactured single-use fixtures.

Here, too, we have such an extensive range of basic, structural, support and clamping elements that, together with the other dk programs, they make up such a complete world of fixation elements that the user only requires additional, customer-specific fabrications for absolutely special parts or very specific processes. Of course, we can also develop and implement these together with you.

Baseplates with tapped holes

Description

Baseplate with M6 holes arranged in a grid pattern.

Material

Hard-coated aluminium.

☞ Custom-made versions available on request.
See pages 184 to 187
for complete sets with fixture elements.



Order No.	Dimensions	Grid	Thread	Weight
395020	300 x 300 x 20	50	M 6	5.0
395030	500 x 250 x 20	50	M 6	7.4
395040	600 x 300 x 20	50	M 6	10.6
395050	800 x 400 x 20	50	M 6	17,6
2999XX	to customer specs.	to customer specs.	to customer specs.	

M 6

Application example



Intermediate plates

Description

T-slot plates for mounting on baseplates with T-slots or M6 tapped holes. For X/Y positioning.

Material

Hard-coated aluminium.

Supplied with

T-slot nuts.



Order No.	No. of slots	Length	Width	Height	Weight
325000	2	117	117	20	0.71
325100	3	117	117	20	0.68

T-Nut 6
T-Nut 6
M 6

Accessories

+ Hand grip

Description

Grip for mounting in a T-slot or M6 hole ease carrying the baseplates.

Contents

1 set of 2 grips and fasteners.



Order No.	Length	Height
328500	150	45

T-Nut 6
M 6

Accessories

+ Plate clamping claws with stop

Description

A set of clamping claws for the 20 mm thick dk grid hole plates. The claws are screwed onto the measuring machine table. Check the table thread sizes before ordering. These elements provide a stop for repeat positioning accuracy while simultaneously securely clamping the dk baseplates.



Order No.	For plate thickness	Thread
281436	20	M 6
281438	20	M 8
281430	20	M 10
281432	20	M 12

Application example



M10 base rail

Description

Adjustable base rail with slot and M10 mounting thread for screwing on columns and articulated arms.

Material

Hard-coated aluminium.

Supplied with

M6 screw for securing to the baseplate.



Order No.	Slot width	Adjustment range	Length	Width	Height
322010	6	60	105	25	12

M 10	M 10
M ...	T-Nut

Application example



M 10 XL base rail

Description

Large and extremely adjustable base rail with slot and M10 mounting thread for screwing on columns and articulated arms. Also has 4 holes for fastening e.g. the quick-action clamps 285206 or vices 270860 and 282110 as well as the users own elements.



Material

Hard-coated aluminium.

Order No.	Slot width	Adjustment range	Length	Width	Height
397012	12.5	80	150	50	20
397013	12.5	130	200	50	20



Fastening accessories



Order No.	Description	Version
397014	Screw with washer	M6 for dk standard plates
397015	Screw with washer	M 8
397016	Screw with washer	M 10
397017	Screw with washer	M 12

Application example



M8 and M10 hexagonal extensions

Description

Hexagonal extension pieces with male thread one end and female thread other end. For screwing on to base rails and, with a thread reducer directly on to dk baseplates. Screw together to increase the height. Width across flats 17 mm.

Material

Stainless steel.



Order No.	Male thread	Female thread	Length
304100	M 8	M 8	50
304200	M 8	M 8	100
322200	M 10	M 10	25
322300	M 10	M 10	35
322400	M 10	M 10	50
304400	M 10	M 10	100
253500	M 10	M 10	150

M 8

M 10

Application example

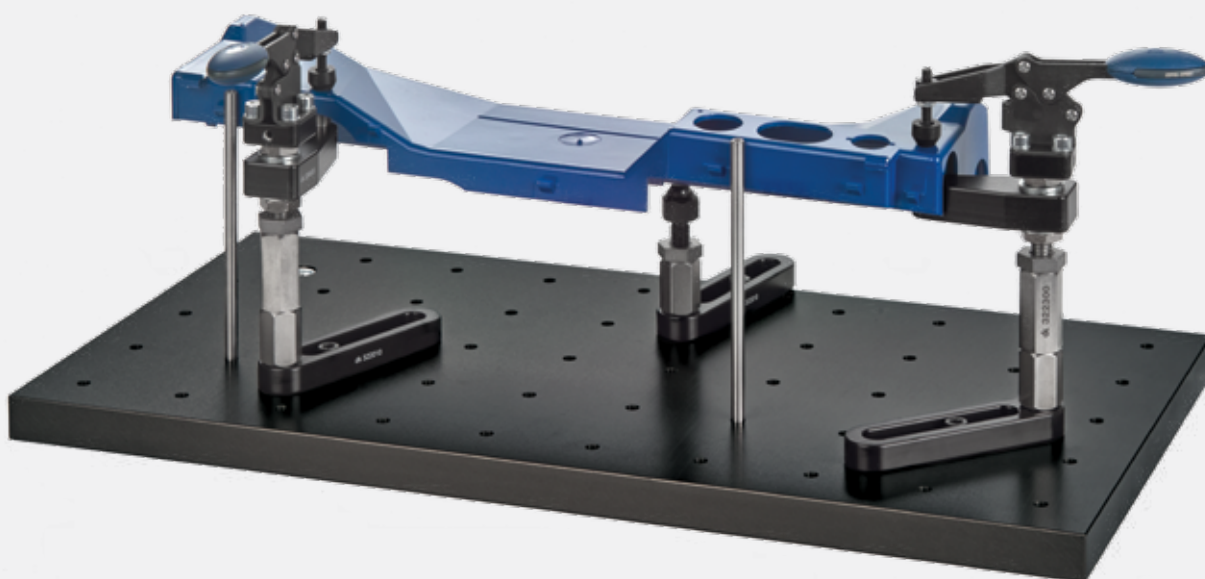

Self-aligning pads M10

Description

Support with flattened, swivel ball to compensate for surface irregularities. Can be screwed onto hexagonal extension pieces or directly into base rails.

Material

Stainless steel/black oxidised steel.

Supplied with

Locknut.



Order No.	Support	Swivel range	Adjustment range	Length
323000	Ø 8	± 15°	15	46

M 10

Screw jacks M10

Description

Height adjustable supports for centring and supporting test parts.

Material

Stainless steel.

Supplied with

Locknut.



Order No.	Version	Adjustment range	Length	Fig.
322600	With 90° point, Ø10	15	50	1
322700	With R5 mm ball end	25	63	2

M 10

Quick-change adapter M 10

Description

Quick-change adapter M 10 for SWA 5 / SWA 8 modules.

Material

Stainless steel.

Supplied with

Locknut.



Order No.	Version	Adjustment range	Length	Fig.
329400	SWA 5	25	55	
329500	SWA 8	25	57	1

SWA 5	SWA 8
M 10	M 10

Accessories

+ Centre points

Description

90° centre points with SWA 8 quick-change mount.

Material

Hard-coated aluminium.

Order No.	Diameter	Height	Fig.
303600	15	20	1
303700	25	20	2
303800	40	24	3

SWA 8



+ Prism supports

Description

120° prism supports with SWA 8 quick-change mount.

Material

Hard-coated aluminium.

Order No.	Clamping range	Prism length	Connection	Height	Fig.
323500	Ø 2-60	8	SWA 8	35	1
323400	Ø 2-60	40	SWA 8	33	2

SWA 8



+ Flat supports

Description

Flat supports in various versions: flat face, straight step and prism step. With SWA 8 quick-change mounts.

Material

Hard-coated aluminium.



Application example



Order No.	Version	Diameter	Height	Step height	Fig.
303805	Flat face	25	20		1
303810	Straight step	25	20	5	2
303815	Prism step	25	20	5	3

SWA 8

Screw jack set with spring finger

Description

Adjustable base rail with support and spring finger. The support height is adjustable.

Material

Hard-coated aluminium/stainless steel.

Supplied with

Base rail (322010), extension piece (322200), jack screw (322700), adapter plate for columns (353700), column with screw (368300), spring finger (302800), locknut and fastening screw.

See T-slot nuts on page 27 for fastening the base rail in a T-slot.



Order No.	Adjustment range	Length	Width	Support height
322005	60	105	25	80-90

M 6 T-Nut

Adjustable stop

Description

Adjustable stop for mounting on $\varnothing 12$ mm columns. Effective length of the stop ca. 130 mm to centre of column.

Material

Hard-coated aluminium/nickel-plated steel.

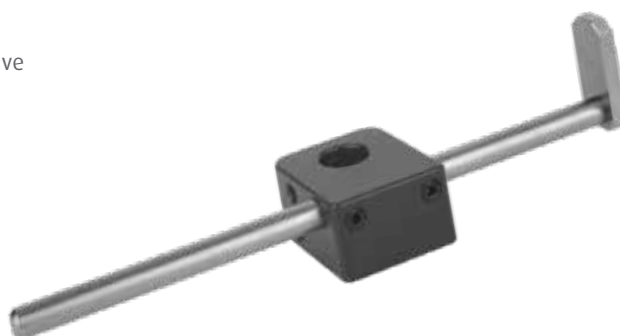

Order No.	Length	Width	Height
287500	35	30	20

D 12

Application example

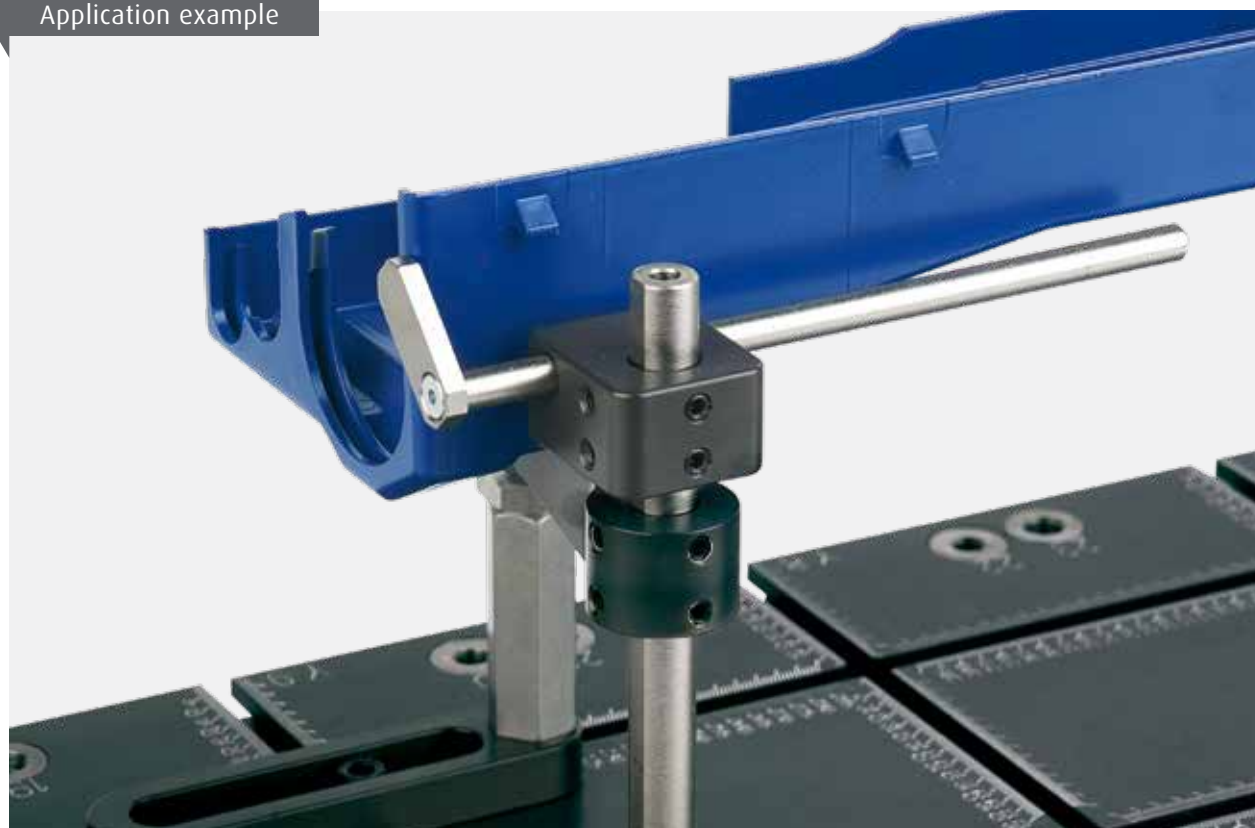

Thread reducer

Description

Thread reducer for connecting different thread sizes e.g. columns, extension pieces, articulated arms, supports etc.

Material

Stainless steel.



Order No.	Male thread	Female thread
275030	M 4	M 8
369000	M 5	M 6
269500	M 5	M 8
275000	M 6	M 8
275010	M 6	M 10
297800	M 8	M 10
275110	M 10	M 6
275100	M 10	M 8
275200	M 12	M 8
275300	M 12	M 10

M ...

Application example

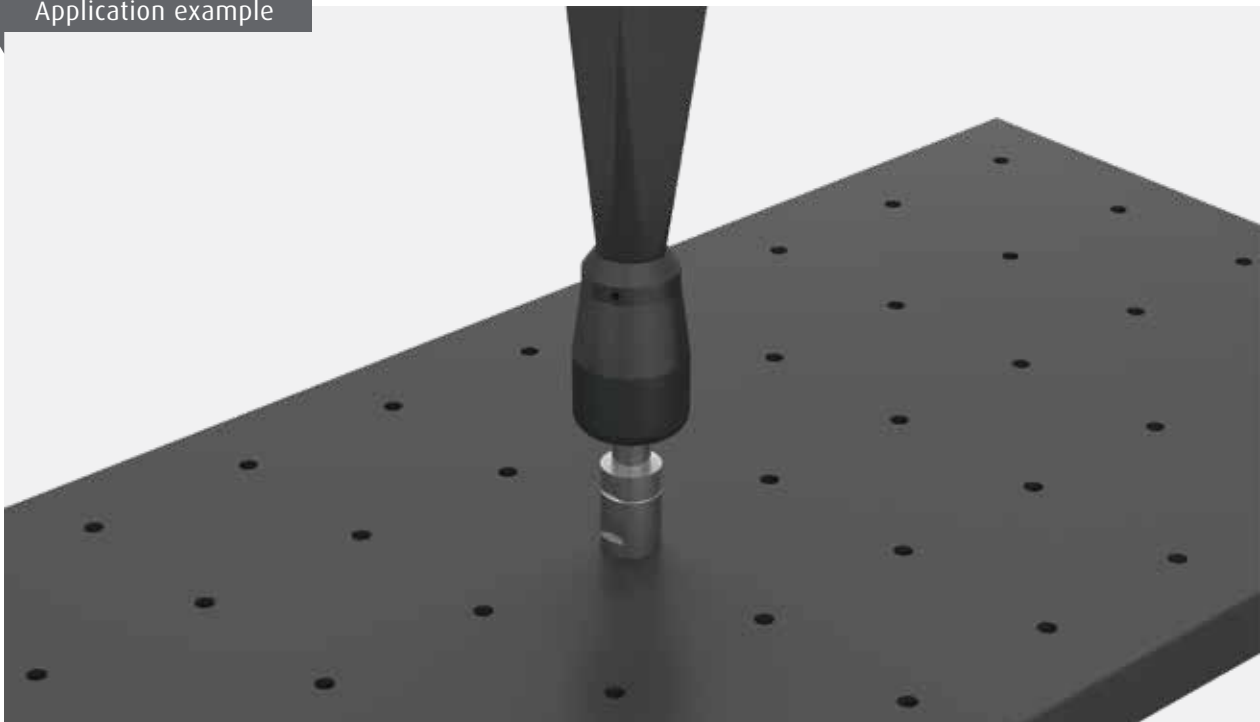

Columns with screw

Description

Columns with threaded connection for mounting spring fingers or for use as a stop element.

Material

Stainless steel.



Application example



Order No.	Column Ø	Thread	Length
269042	4	M 4	30
269043	4	M 4	50
269044	4	M 4	75
368100	6	M 6	30
368120	6	M 8	30
368200	6	M 6	50
368220	6	M 8	50
368300	6	M 6	75
368400	6	M 6	100
368500	6	M 6	125
368505	6	M 6	150
368600	12	M 6	50
368620	12	M 8	50
368700	12	M 6	100
368720	12	M 8	100
368800	12	M 6	150
368820	12	M 8	150
368900	12	M 6	200
368920	12	M 8	200
368610	12	M 10	50
368710	12	M 10	100
368810	12	M 10	150
368910	12	M 10	200

M ...

Articulated arms

Description

Progressive clamping articulated arms with a connection screw in the base and a quick-change adapter on the arm. Mechanical articulated arm. Central locking. Holding force at right angles 100 N (type MU) or 80 N (type SU).



Application example

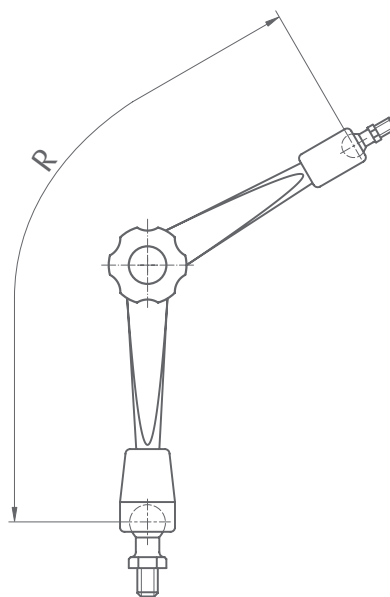
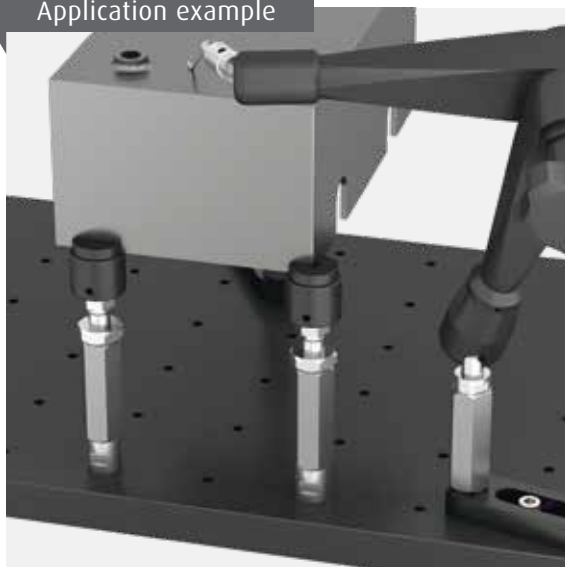

Order No.	Model	Thread	Adapter	Action range (R)
296800	SU	M 8	SWA 5	160
296700	SU	M 8	SWA 8	160
296900	MU	M 10	SWA 5	280
297000	MU	M 10	SWA 8	280



Application examples

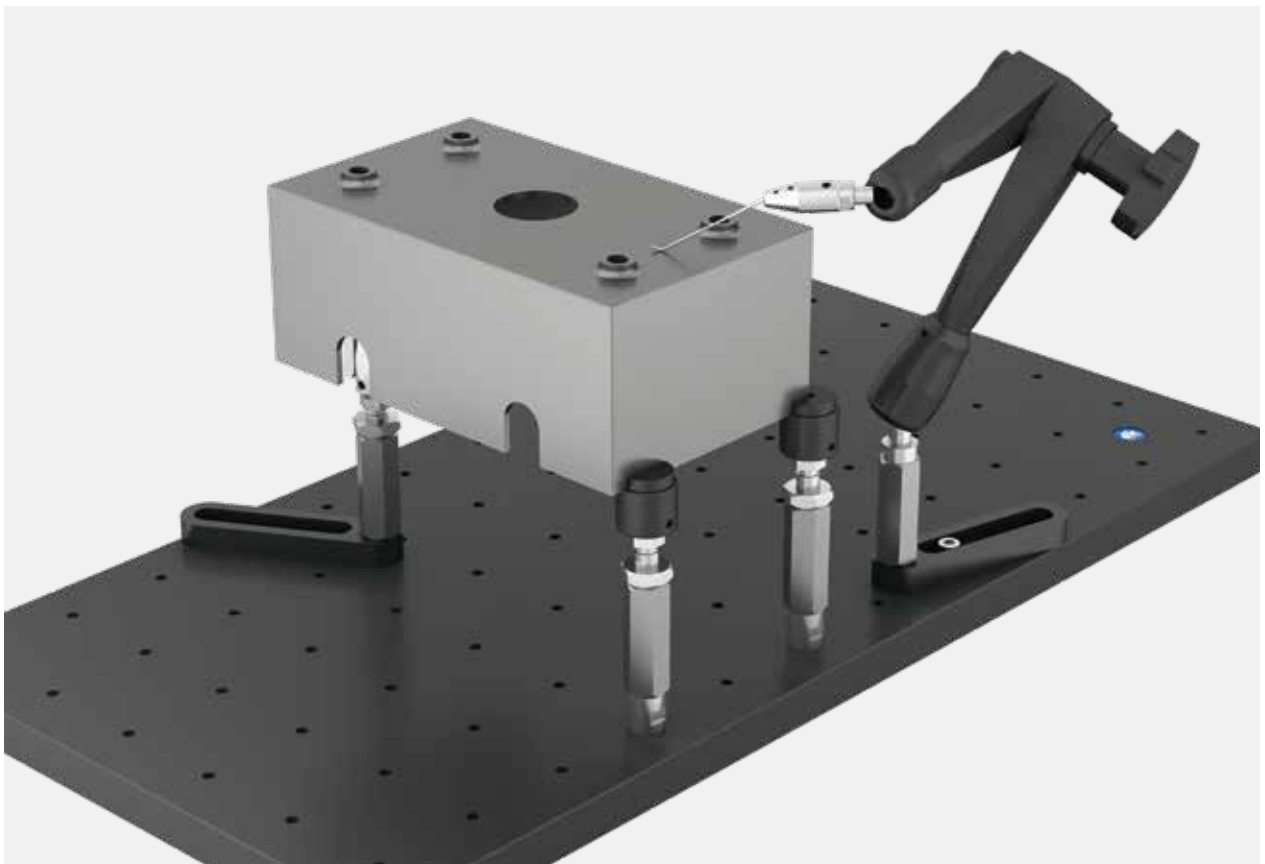
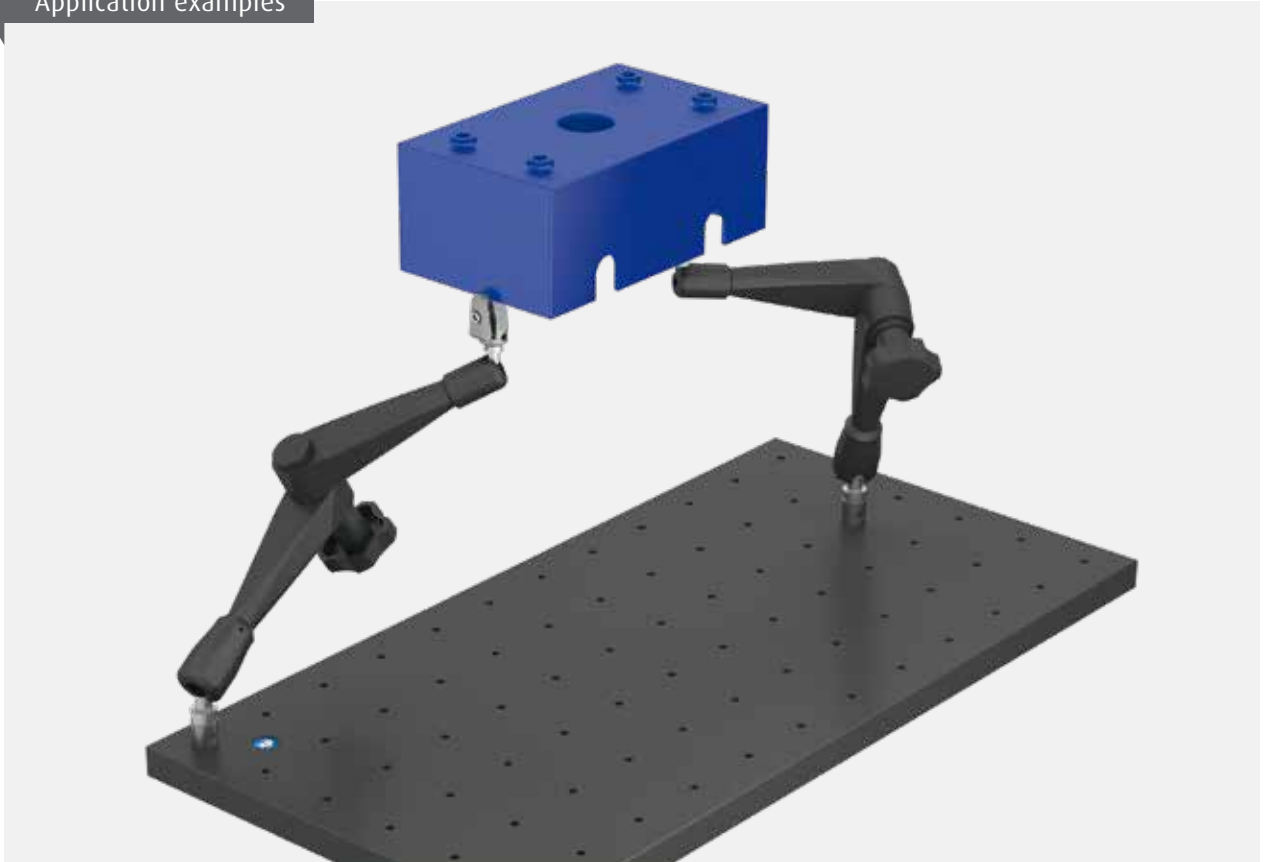

Spring fingers

Description

For the simple and quick holding down of workpieces.
Self-locking on round columns due to the applied tension by manually pressing down.

Material

Stainless steel.



Application example

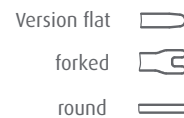
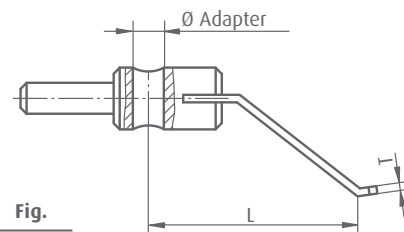

Order No.	Adapter Ø	Version	T	L	Fig.
269037	4	Flat	0.4	30	
343700	4	Flat	0.8	30	
269038	4	Round	1.1	40	
269039	4	Round	1.1	60	
343710	4	Flat	0.8	30	
302750	6	Round	1.1	50	
302760	6	Round	1.5	50	
302800	6	Flat	1	50	1
302900	6	Flat	1	75	
302810	6	Flat	1	90-125	2
302910	6	Flat	1	115-150	
302300	12	Flat	1	75	3
302400	12	Flat	1	95	
302320	12	Flat	1	120-150	
302500	12	Flat	1.5	75	
302600	12	Flat	1.5	95	
302520	12	Flat	1.5	120-150	
302350	12	Round	2.5	80	4
302340	12	Round	3	80	
302510	12	Forked	1.5	75	5
302610	12	Forked	1.5	95	

Columns with screw

Description

Columns with threaded connection for mounting spring fingers or for use as a stop element.

Material

Stainless steel.



Application example



Order No.	Column Ø	Thread	Length
269042	4	M 4	30
269043	4	M 4	50
269044	4	M 4	75
368100	6	M 6	30
368120	6	M 8	30
368200	6	M 6	50
368220	6	M 8	50
368300	6	M 6	75
368400	6	M 6	100
368500	6	M 6	125
368505	6	M 6	150
368600	12	M 6	50
368620	12	M 8	50
368700	12	M 6	100
368720	12	M 8	100
368800	12	M 6	150
368820	12	M 8	150
368900	12	M 6	200
368920	12	M 8	200
368610	12	M 10	50
368710	12	M 10	100
368810	12	M 10	150
368910	12	M 10	200

M ...

Adapter plates for columns

Description

Adapter plates for columns with M6 threads (e.g. for spring fingers) for mounting on M8 and M10 hexagonal extension pieces, self-aligning pads, rest pins and M10 quick-change adapters.

Material

Stainless steel.



Order No.	Hole	Overhang
353700	Ø 10	50
353800	Ø 10	72

Application example



Spring fingers with quick-change adapter

Description

Spring finger with SWA 5 quick-change mount for fastening to articulated arms.

Material

Stainless steel.

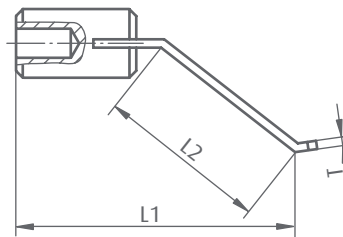

Order No.	Connection	T	L1	L2	Version	Fig.
269300	SWA 5	1.1	55	35	Round	
268300	SWA 5	1.1	70	50	Round	1

SWA 5

Application example

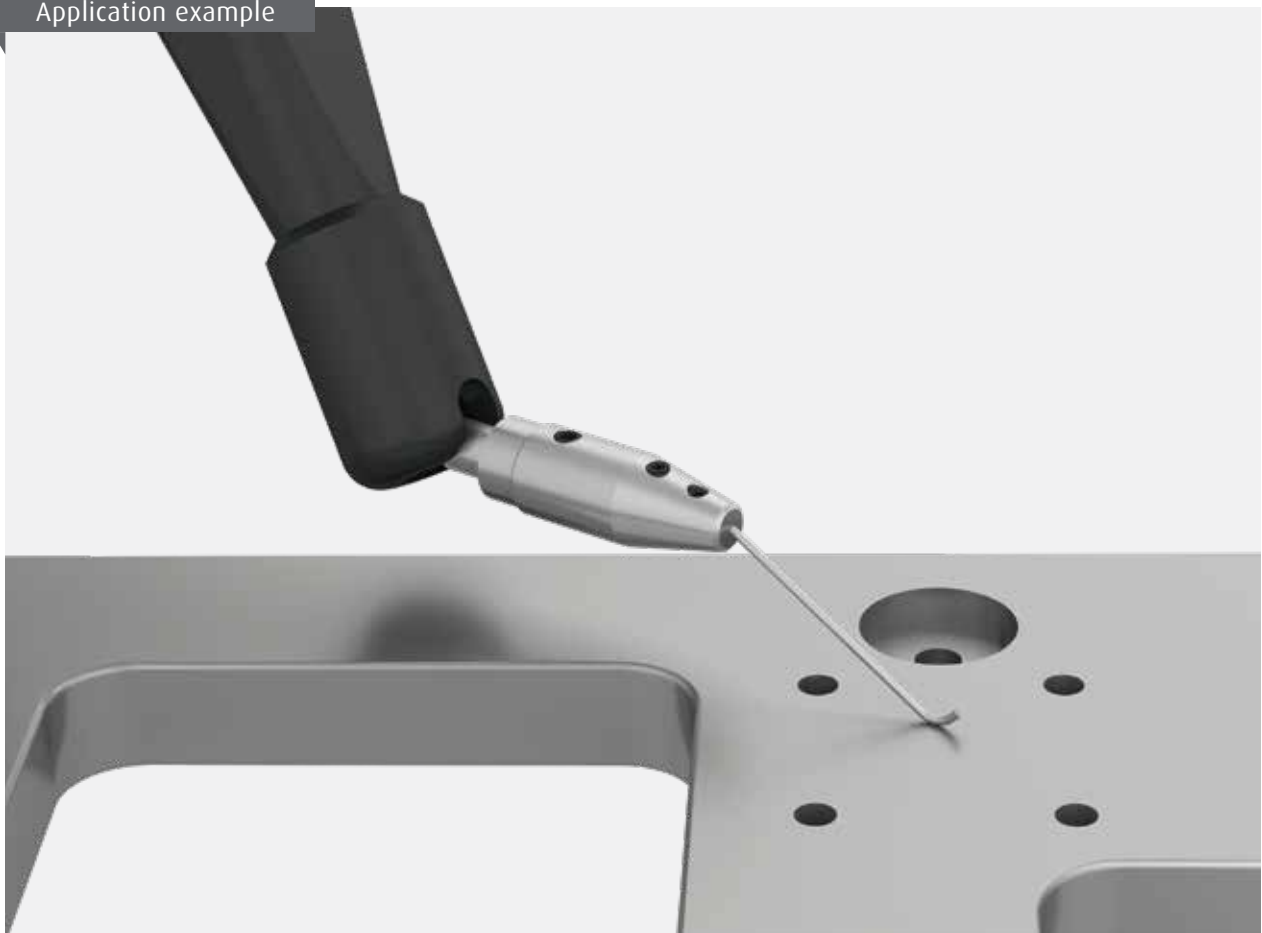

Toggle clamps with support

Description

Toggle clamps with support and M10 thread.

Supplied with

Locknut.



Application example



Order No.	Overhang	Clamping range	Height
336300	32	0-20	100
336400	51	0-27	115

M 10

Application example



Application example

Toggle clamp (used without support) with workpiece...

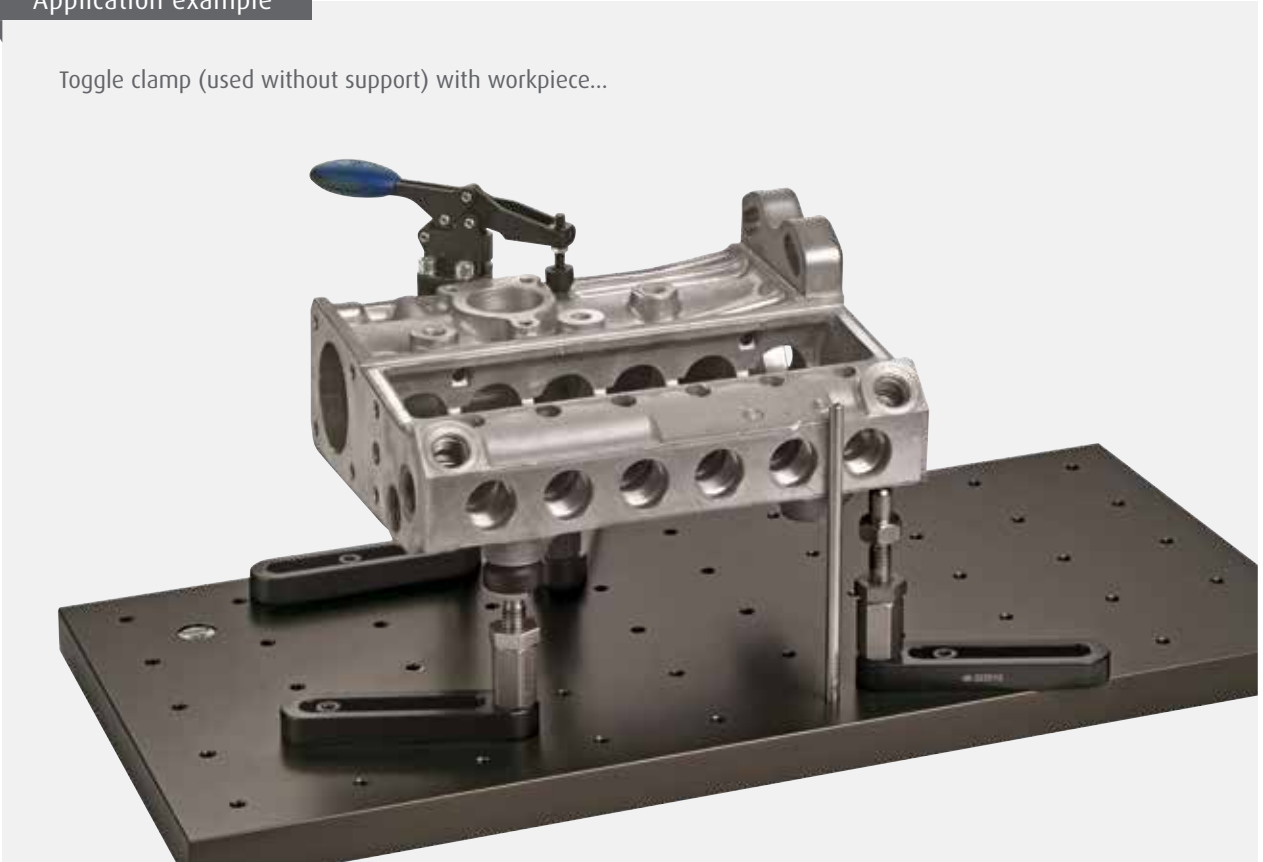

...and without workpiece



Parallel clamps

Description

Parallel clamps with a maximum clamping range of 75 mm. The jaw blocks have 4 faces and are available in different versions - flat, with a prism for holding round workpieces or convex for holding workpieces that are highly sensitive to bending. The clamps are mounted on SWA 5 or SWA 8 quick-change adapters.

Material

Stainless steel/steel/aluminium.



Application examples

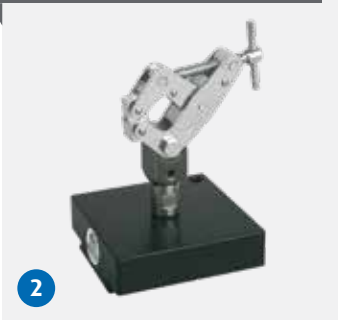

Combined with an SWA 5 quick-change mount on an SWA 29 adapter... or on an articulated arm



Order No.	Clamping range	Connection	Jaw faces	Version	Fig.
278800	0-25	SWA 5	3 flat, 1 long prism	Both jaws rotatable	1
278600	0-25	SWA 5	2 flat, 1 long prism, 1 convex	Both jaws rotatable	1
278400	0-25	SWA 8	3 flat, 1 long prism	Both jaws rotatable	1
334900	0-25	SWA 8	2 flat, 1 long prism, 1 convex	Both jaws rotatable	1
278500	0-25	SWA 39	3 flat, 1 long prism	Both jaws rotatable	2
279610	0-50	SWA 8	3 flat, 1 long prism	Both jaws rotatable	
279620	0-75	SWA 8	3 flat, 1 long prism	Both jaws rotatable	

Parallel clamps with guide pin

Description

Parallel clamp with guide pin fixed in lower jaw to secure the jaws against rotation. Mounted on SWA 5, SWA 8 or SWA 39 quick-change adapters.

Material

Stainless steel/aluminium.

Application example



Order No.	Clamping range	Connection	Version	Fig.
279200	0-25	SWA 5	cross prism in lower jaw	
279210	0-25	SWA 8	cross prism in lower jaw	
279600	0-50	SWA 8	cross prism in lower jaw	1
279300	0-50	SWA 39	cross prism in lower jaw	2

SWA 5

SWA 8

SWA 39

Application example



Tension clamp

Description

Tension clamp for mounting on articulated arms. The tension clamp is designed for use with an articulated arm, the draw hook is pulled out by hand and hooked over a workpiece to provide tension. Connection with SWA 8 quick-change mount.

Material

Stainless steel.



Order No.	Connection	Size	Length	Hook travel	Tensile force (N)
376800	SWA 8	hook shaft Ø10	81	11	80

SWA 8

Prism with spring finger

Description

120° prism on a column with a spring finger. Connection with SWA 8 quick-change mount.

Material

Stainless steel.

Application example

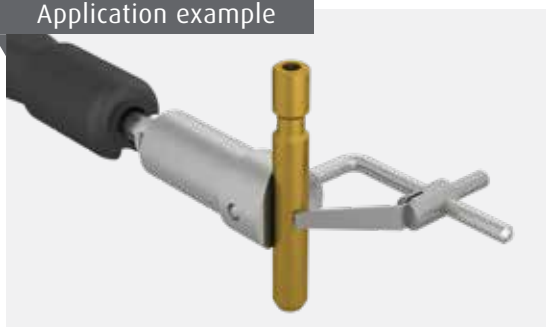

Order No.	Connection	Clamping range	Prism length	Height
285810	SWA 8	Ø 2–25	20	45

SWA 8

Clips

Description

Clip for fixating thin, rigid parts.
Clamping with a ball-head screw. Connection with SWA 5 or SWA 8 quick-change mount.

Material

Steel.



Application example

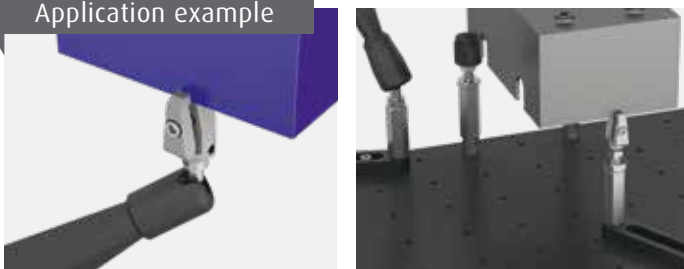

Order No.	Connection	Jaw depth	Clamping width
302100	SWA 5	5	3
302000	SWA 8	5	3

SWA 5

SWA 8

Accessories

+ Four-way hexagon key

Description

Practical and compact cross design with 3 key sizes per tool. Covers all hexagon socket sizes used in the Spannfix and Schienenfix ranges.

Material

Steel/stainless steel.

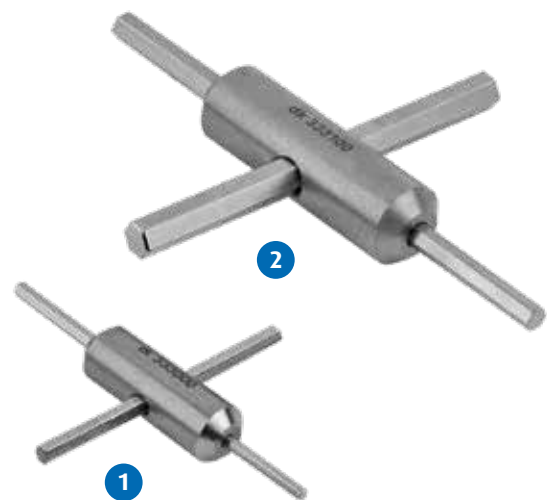

Order No.	Size	Fig.
333000	2 / 2.5 / 3	1
333100	4 / 5 / 6	2

Quick-action clamp with fastening screw

Description

SWA 39 quick-action clamp for direct mounting in tapped holes or T-slots. Mounted on a 12mm high intermediate plate.

Material

Hard-coated aluminium/stainless steel.

Supplied with

Fasteners



Order No.	Fastening screw	Height
285204	M 4	23.5
285205	M 5	23.5
285206	M 6	23.5
285208	M 8	23.5
285210	M 10	23.5
285212	M 12	23.5

SWA 39
M ...

Application example



Application examples

The SWA39 elements can form a support in the context of the fixation of large parts e.g. when using the *NADELFIX* negative form range.

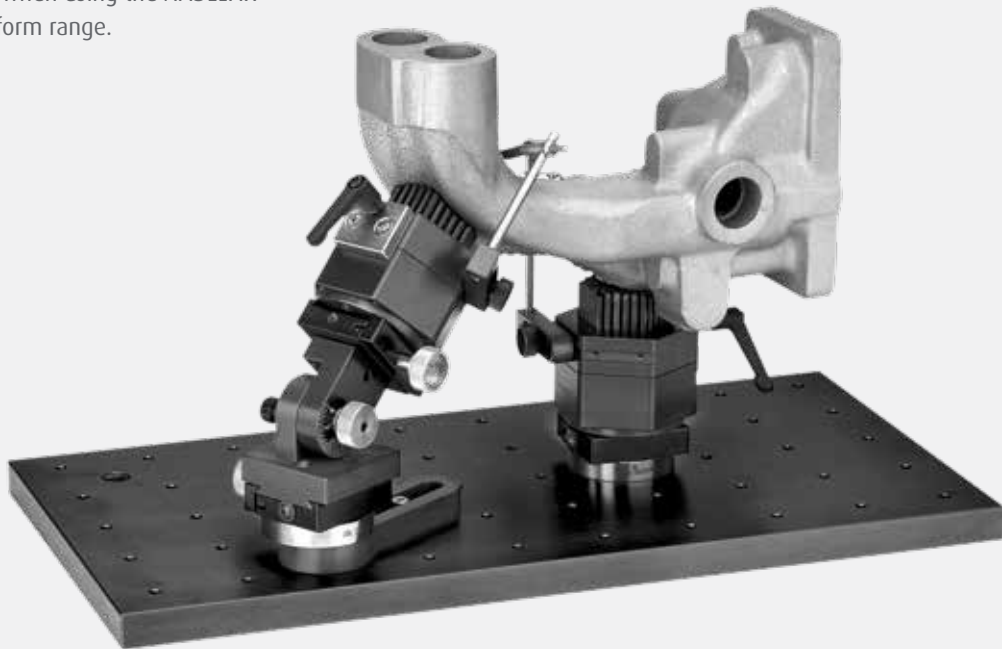

Especially in combination with standard clamping elements such as vice and chucks, the system offers a rapid and extremely flexible, exactly reproducible positioning of clamping elements by means of the SWA 39 quick-action clamp for M 6.

The result is a zero-point clamping setup for workpieces which can be dismantled and identically reassembled.



Spannfix ECO basic set

Description

Set with diverse supports, extension pieces and stops. Workpieces are held using spring fingers.

The basic part is a baseplate with M6 mounting holes for rapid and flexible positioning of modular elements.

Available in sizes 500 x 250 mm or 600 x 300 mm.

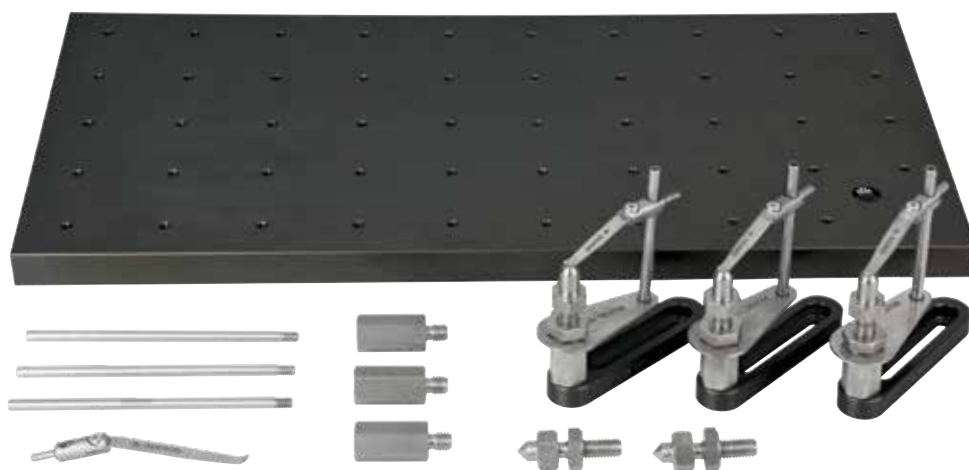

Application example

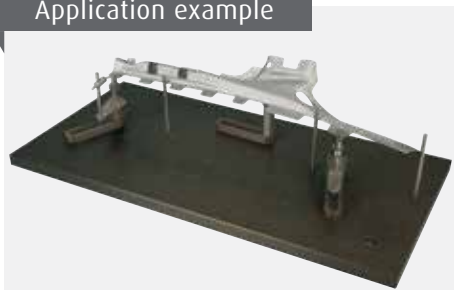

Set versions

Order No.	Description
285130	Spannfix ECO basic set "1"
285140	Spannfix ECO basic set "2"

Set contents

Order No.	Description	Set "1"	Set "2"
395030	Baseplate with tapped holes, 500 x 250 mm	1	-
395040	Baseplate with tapped holes, 600 x 300 mm	-	1
322005	Screw jack set with spring finger	3	3
322600	Screw jack with 90° point	2	2
322300	35 mm extension piece	3	3
368500	125 mm columns, for spring finger or as stops	3	3
302900	75 mm spring finger	1	1

Spannfix ECO expansion set

Description

Expansion set with diverse support, extension and clamping modules.

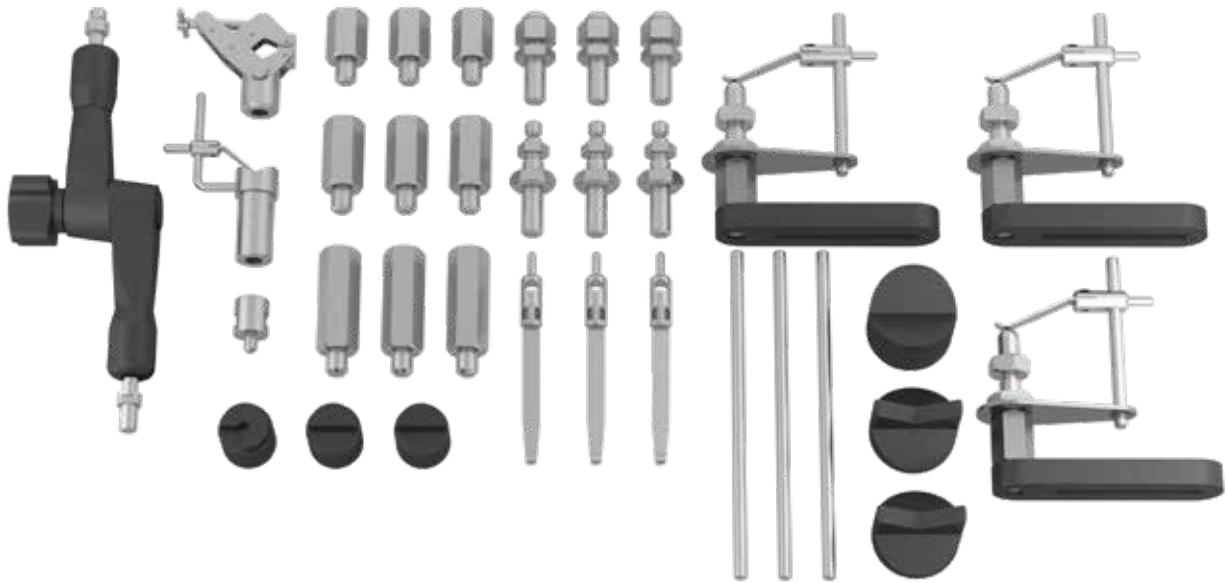

Set versions

Order No.	Description
285155	Spannfix ECO expansion set

Set contents

Order No.	Description	Quantity
296700	SU/SWA 8 articulated arm	1
278400	0-25 mm parallel clamp	1
285810	Prism with spring finger	1
322200	25 mm extension piece	3
322300	35 mm extension piece	3
322400	50 mm extension piece	3
323000	Self-aligning pads M10	3
329500	M 10/SWA 8 quick-change mount	3
275000	Thread reducer M6/M8	1
322005	Screw jack set with spring finger	3
368505	150 mm column for spring finger	3
302900	75 mm spring finger	3
303810	SWA 8 stepped support	2
303815	SWA 8 angular support	1
323500	SWA 8 120° prism, 8 mm	2
323400	SWA 8 120° prism, 40 mm	1

Spannfix ECO complete set

Description

The set contains diverse supports, extension pieces and stops. Workpieces are held using spring fingers or parallel clamps. The basic part is a baseplate with M6 mounting holes for rapid and flexible positioning of modular elements. Set "1" includes a 500 x 250 mm baseplate, set "2" includes a 600 x 300 mm baseplate. The complete set enables a wide variety of metal and plastic plate, milled and turned parts to be clamped.

Ordering information

When ordering, let us know the thread or T-slot size on your measuring equipment.

Set contents

Order No.	Description
285160	Spannfix ECO complete set "1"
285170	Spannfix ECO complete set "2"

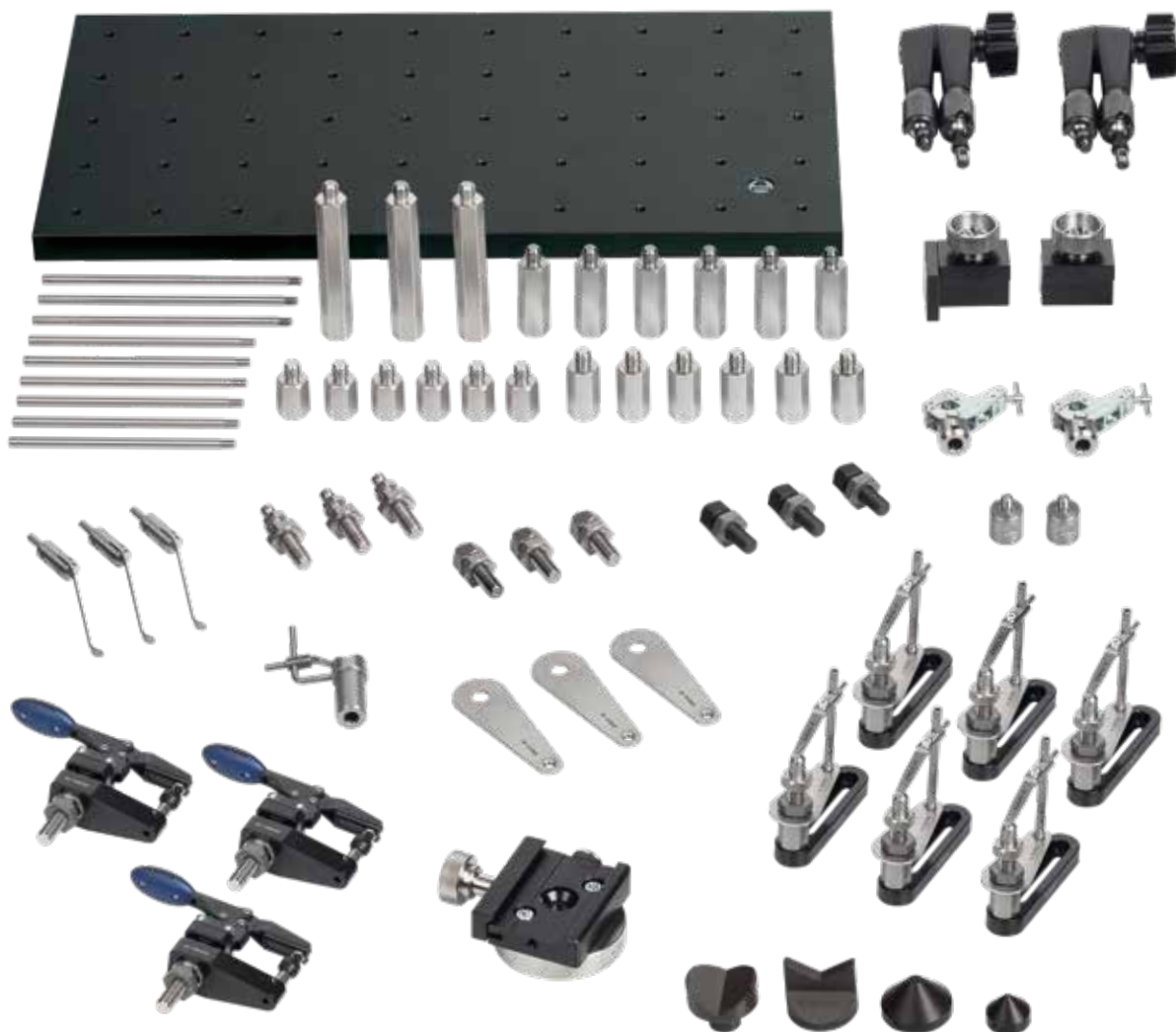

Set contents

Order No.	Description	Set "1"	Set "2"
395030	Baseplate with tapped holes, 500 x 250 mm	1	
395040	Baseplate with tapped holes, 600 x 300 mm		1
281436	Baseplate clamping claws (set)	1	1
285206	Quick-action clamp	1	1
322005	Screw jack set with spring finger	6	6
322600	Screw jack with 90° point	3	3
323000	Self-aligning pads	3	3
368500	125 mm columns, for spring finger or as stops	6	6
368505	150 mm columns, for spring finger or as stops	3	3
353800	Adapter plates for columns	3	3
302900	75 mm spring finger	3	6
322200	25 mm extension	6	6
322300	35 mm extension	6	6
322400	50 mm extension	6	6
304400	100 mm extension	3	3
336400	Toggle clamps with support	3	3
329500	Quick-change mounts	3	3
323500	8 mm prism 120°	1	1
323400	40 mm prism 120°	1	1
303700	25 mm centre point, 90°	1	1
303800	40 mm centre point, 90°	1	1
275000	Thread reducer M6/M8	2	2
296700	Articulated arms type SU	2	2
278400	0-25 mm parallel clamp	2	2
285810	120° prism with spring finger	1	1

Application example



QUADERFIX

Clamping system for tactile measuring – Cuboid elements

- » Modular fixture system constructed from standard cuboid elements
- » Drilled through holes on a 25 mm grid
- » Compatible with the *SPANNFIX* product range

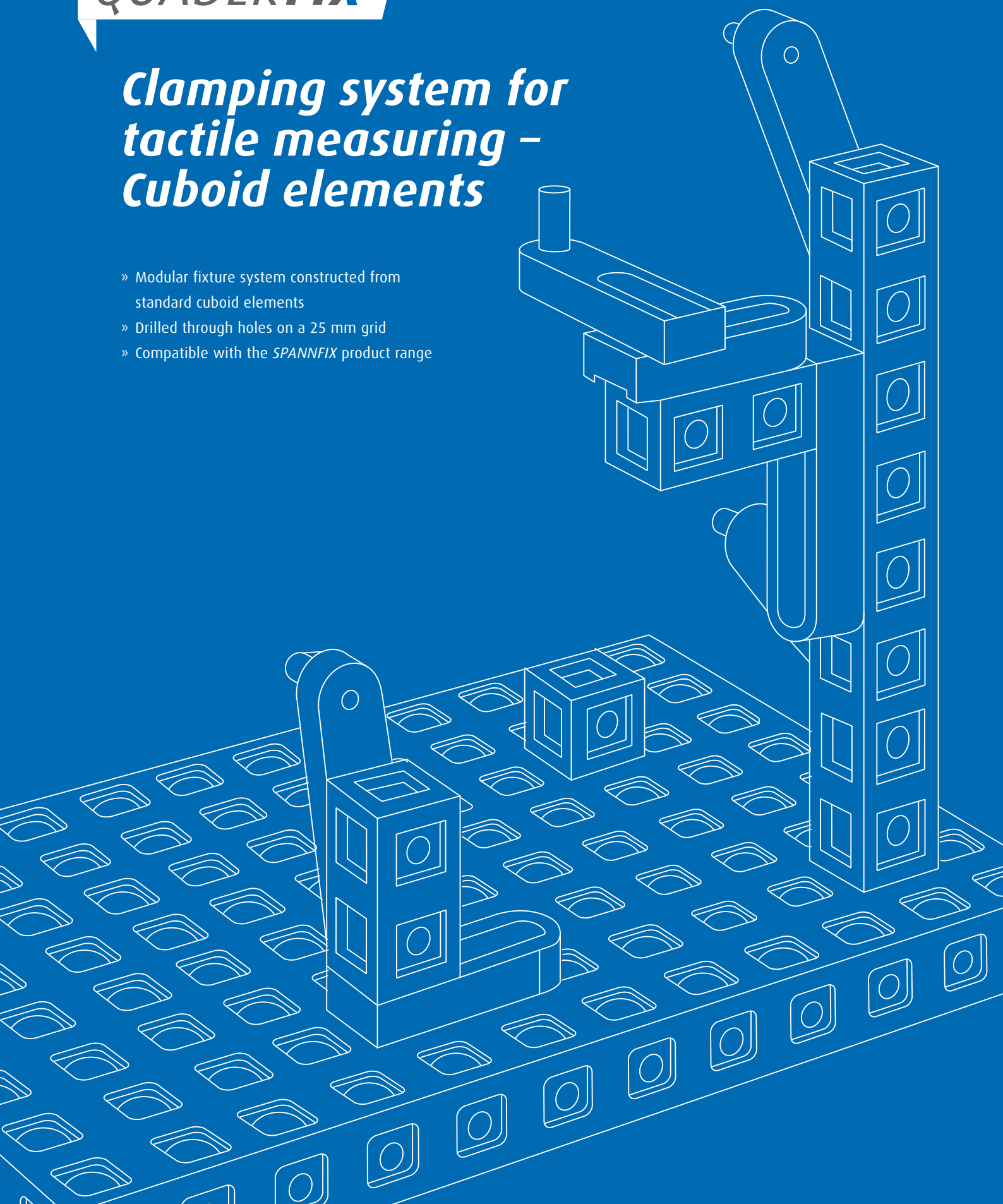

Basic elements
+ accessories



Cuboid baseplates

Page 192 [+](#)

Structural elements
+ accessories



Cuboid columns

Page 194



Cuboid plates

Page 195



Cuboid V-blocks

Page 196



Cuboid inverted V-block pairs

Page 196



Cuboid reinforcement brackets

Page 198



Cuboid reinforcement struts

Page 198



Cuboid rotatable adapters

Page 199



Column connector swivelling

Page 199



Cuboid adjustable mounting rails

Page 200



Cuboid X/Y positioning elements

Page 200



Bushes and adapters

Page 201



Adapter nut

Page 201



Rail for support pins

Page 202



Adapter for support pins

Page 202



Support pins

Page 203



Hexagonal extensions M6

Page 204



Jack screws M6

Page 204



Base rail M10

Page 206



Thread reducer extension piece

Page 206



Hexagonal extensions M10

Page 207



Self-aligning pads M10

Page 208



Jack screws M10

Page 208



Quick-change mount M10

Page 209



Screw jack set with spring finger

Page 210 [+](#)



Cuboid stops

Page 211

Clamping elements



Spring fingers

Page 212



Columns with screw

Page 213



Adapter plates for columns

Page 214



Toggle clamps with support

Page 215



Cuboid T-slot adapter

Page 216



Quick-action clamp Quaderfix

Page 217

Sets

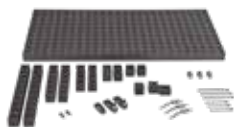

Quaderfix basic set

Page 218



Quaderfix expansion set

Page 220



Quaderfix fasteners

Page 221

Reproducible, anti-twist 3D fixtures through profile grid pattern

QUADERFIX elements are as easy to understand as building blocks, free spatial positioning and as rigid as if milled from a solid block. The program is so variable and simultaneously, equipped with so many accessories and high compatibility to the other dk fixating systems that highest versatility is the result. Even though QUADERFIX is basically designed to support dk's market leadership in the field of test piece sizes up to 1,000 mm, there is no weight and size limit for the workpieces to be mounted in this fixation program. It is therefore ideal for providing users optimum support where part sizes are mainly, but not only in the medium size range. The system integrity over basic, construction, positioning and clamping elements applies within QUADERFIX and at the same time extends over the majority of the other dk fixation systems. This makes this program incredibly high-performance.

QUADERFIX is therefore integral to dk's unique market position as developer, manufacturer and retailer of user-oriented, efficient and sustainable fixturing systems.

Basic elements

- 1 Cuboid baseplate (page 192)



- Other accessories (page 193)



Structural elements

- 2 Cuboid columns (page 194)



- 3 Support pins (page 203)



- 4 Cuboid X/Y positioning element (page 200)



- 5 Adapter nut (page 201)



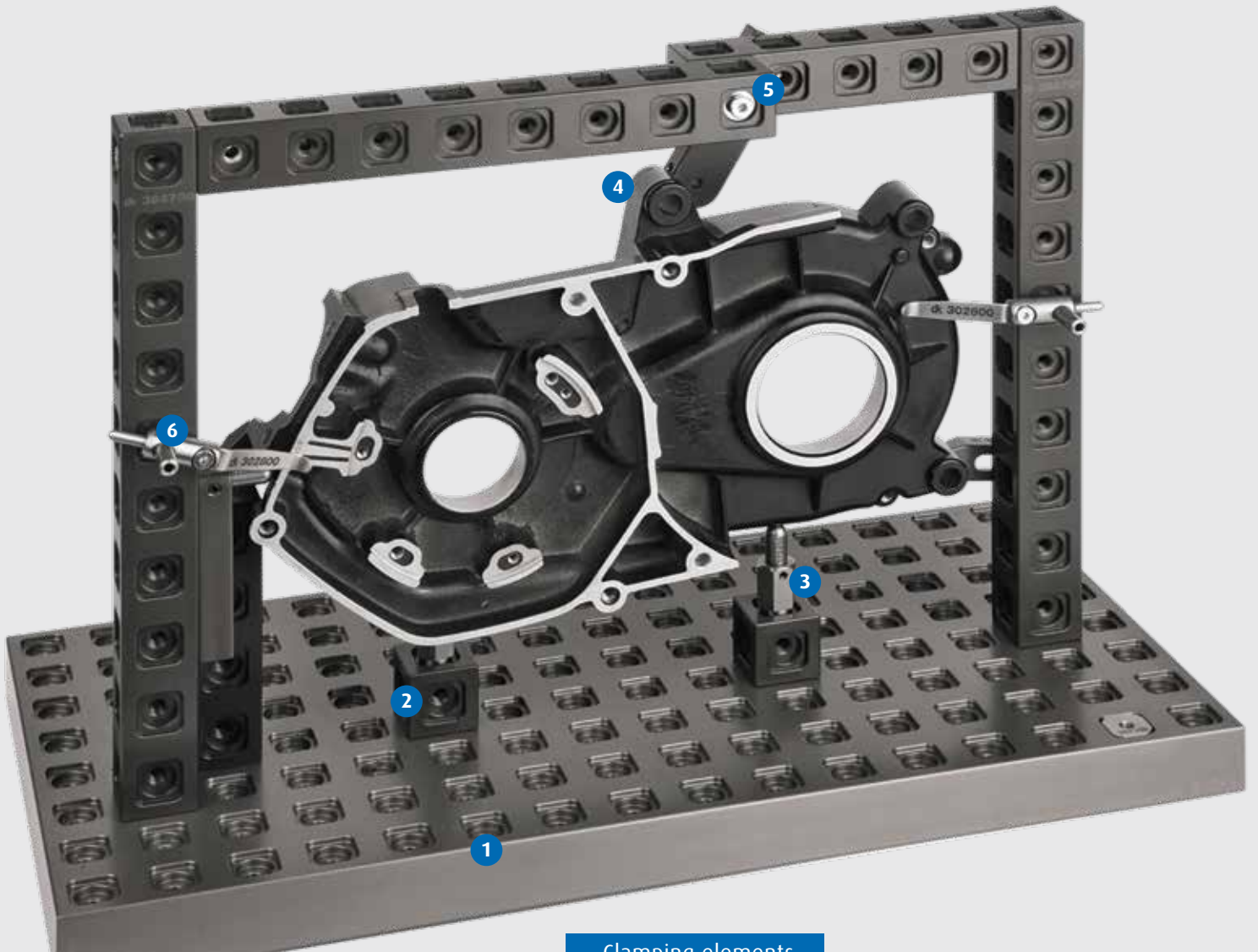

Other versions
(pages 195–197)



Accessories (page 202)



Other versions (page 200)



Clamping elements

6 Spring fingers (page 212)



All clamping elements included in Spannfix PRO (pages 130 to 143) and Spannfix ECO (pages 172 to 181) can also be used with the QUADERFIX system.



**FAST
REASSEMBLY
LIFELONG**

Cuboid baseplates

Description

Baseplate with square push-fit sockets for anti-twist mounting of the modular elements and M6 connection threads in a 25 mm grid pattern.



Material

Hard-coated aluminium.

Order No.	Length	Width	Height	Weight
361700	400	200	25	4.7
362000	500	250	25	7.4
362100	600	300	25	10.7

Quad

Application example

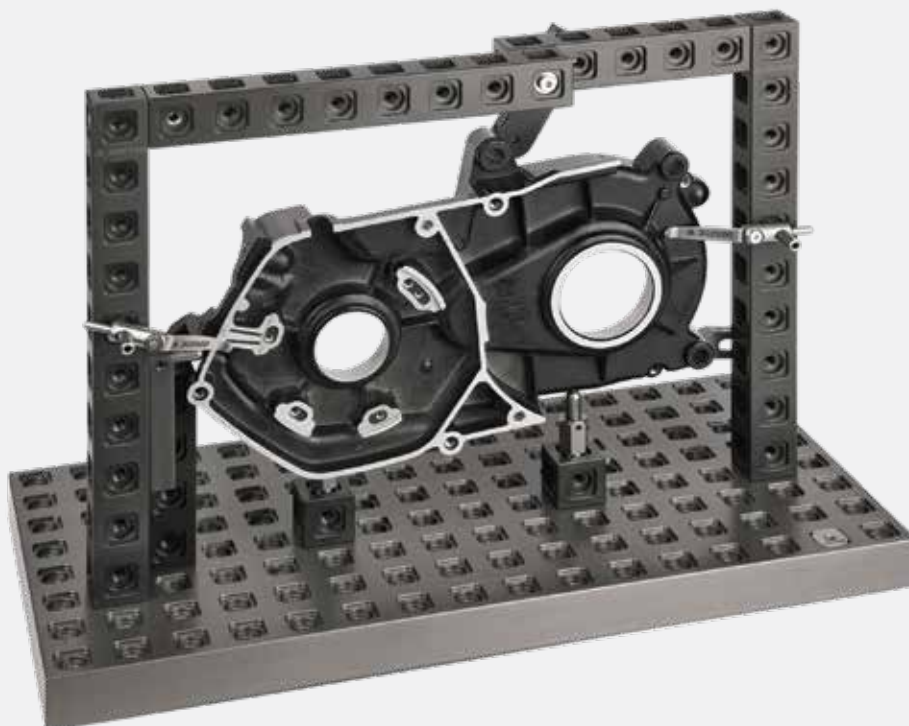

+ Column and plate connector

Description

Plate connector for Quaderfix baseplates.
For joining columns and plates.

Material

Hard-coated aluminium.



Order No.	Length	Width	Height	
363300	100	25	12	Quad

+ Clamping claws

Description

A set of clamping claws for the 25 mm thick dk Quaderfix plates. The claws are screwed onto the measuring machine table. Check the table thread sizes before ordering. These elements provide a stop for repeat positioning accuracy while simultaneously securely clamping the dk baseplates.



Order No.	For plate thickness	Thread	Contents
281406	25	M 6	1 set
281408	25	M 8	1 set
281410	25	M 10	1 set
281412	25	M 12	1 set

M ...

Application example

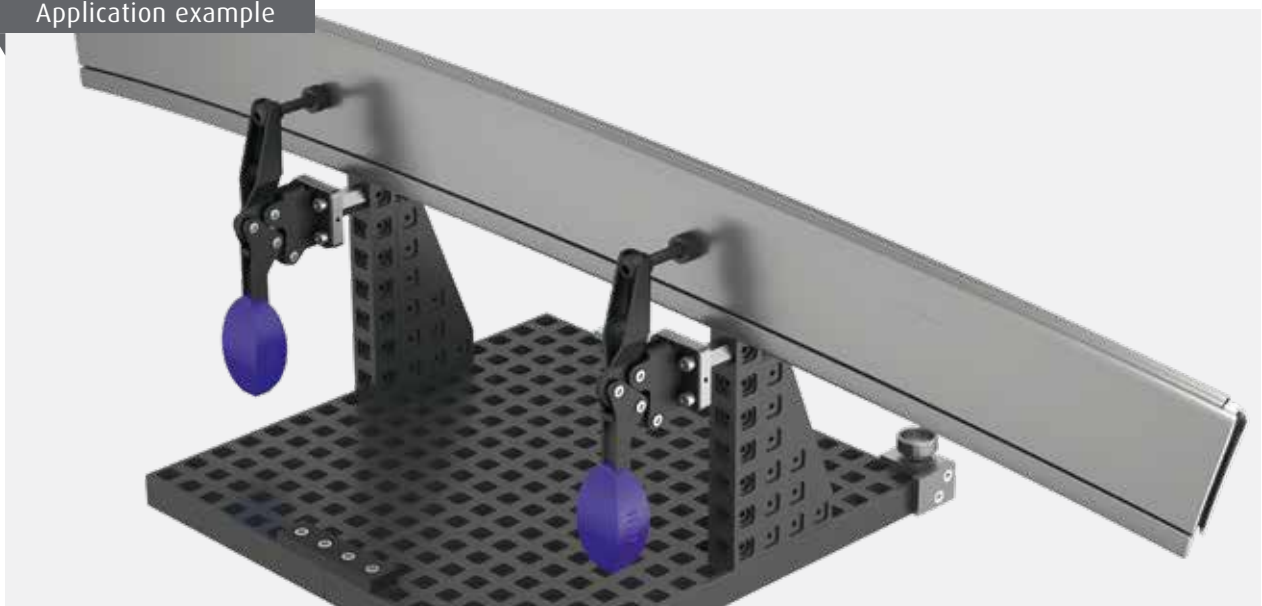

Cuboid columns

Description

Cuboid column with a 25 mm connection thread spacing. Square push-fit sockets for anti-twist mounting of module elements with M6 connection threads, M5 on end faces.

Material

Hard-coated aluminium.



Application example

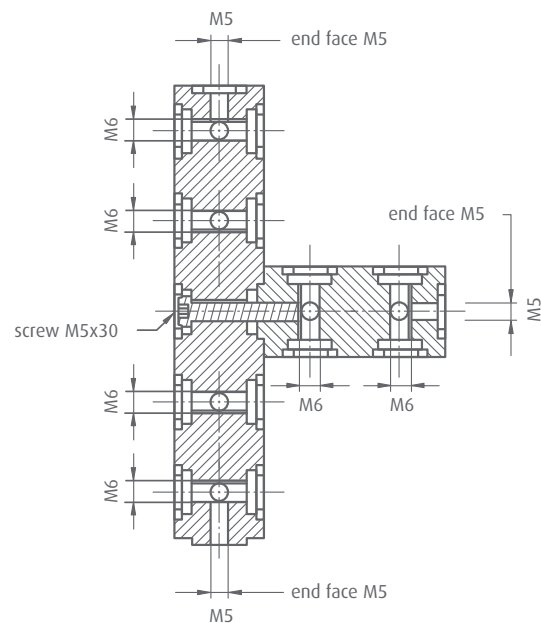

Order No.	Length	Width	Height	Weight
364000	25	25	25	0.03
364100	50	25	25	0.07
364200	75	25	25	0.1
364300	100	25	25	0.13
364400	125	25	25	0.17
364500	150	25	25	0.2
364600	200	25	25	0.27
364700	250	25	25	0.34
364800	500	25	25	0.68



Cuboid plates

Description

Cuboid plates with a 25 mm grid pattern. Square push-fit sockets for anti-twist mounting of module elements with M6 connection threads, M5 on side faces. Also suitable as baseplate for smaller clamping tasks.

Material

Hard-coated aluminium.



Application examples



Order No.	Length	Width	Height	Weight
360100	50	100	25	0.29
360300	50	150	25	0.43
360400	50	200	25	0.57
360500	50	250	25	0.72
360600	50	500	25	1.44
360900	100	200	25	1.3
361600	200	300	25	3.6

Quad

Cuboid V-blocks

Description

Cuboid 120° V-blocks Square push-fit socket for anti-twist mounting of module elements with M6 connection threads, M5 on top faces.

Material

Hard-coated aluminium.

Contents

1 pair.



Order No.	Length	Width	Height	Clamping Ø	Weight	Fig.
359400	100	25	50	100	0.27	1
359500	150	25	50	200	0.36	

Quad

Cuboid inverted V-block pairs

Description

Pair of inverted V-blocks. Square push-fit sockets for anti-twist mounting of module elements with M6 connection threads, M5 on bottom face.

Material

Hard-coated aluminium.

Contents

One pair.



Order No.	Prism	Length	Width	Height	Weight	Fig.
359600	90°	25	25	25	0.04	1
359700	90°	50	25	25	0.08	
359800	120°	25	25	25	0.04	
359900	120°	50	25	25	0.07	

Quad

Application examples

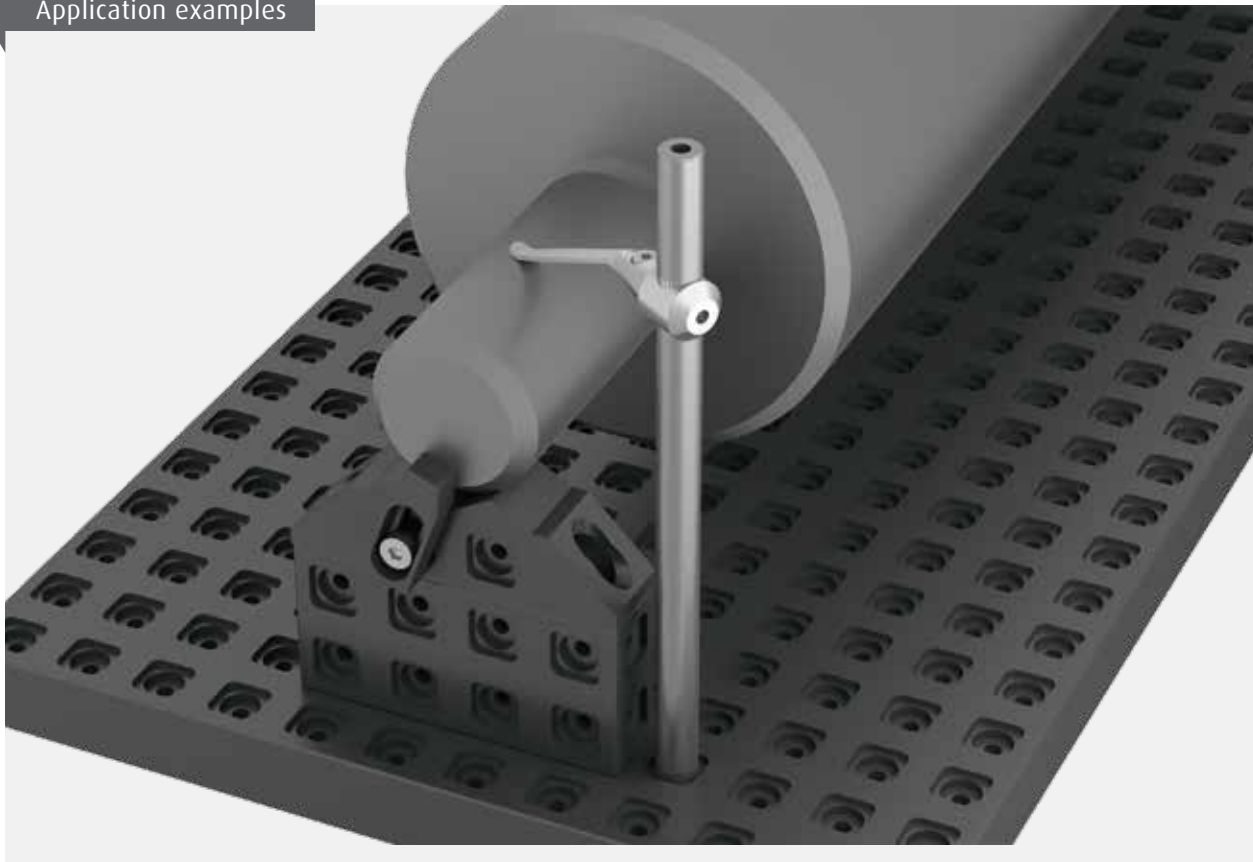

Cuboid reinforcement brackets

Description

Angle block for reinforcement or to ease assembly. With the bracket 366000 cuboid columns or V-block elements can be mounted on the baseplate from above. Fastening from the plate underside is not required.

Material

Hard-coated aluminium.



Application example

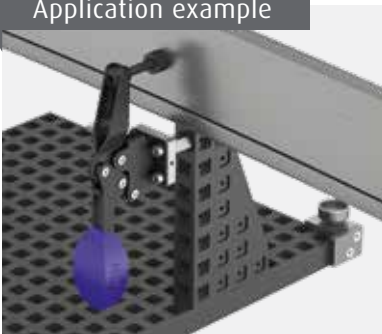

Order No.	Length	Width	Height	Weight
366000	25	25	25	0.04
357000	100	50	25	0.24
357100	150	75	25	0.49

Quad

Cuboid reinforcement struts

Description

Struts for increasing rigidity and strengthening larger constructions or by very heavy workpieces.

Material

Hard-coated aluminium.

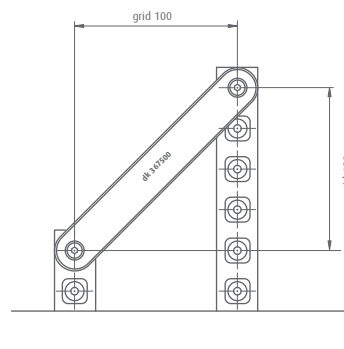
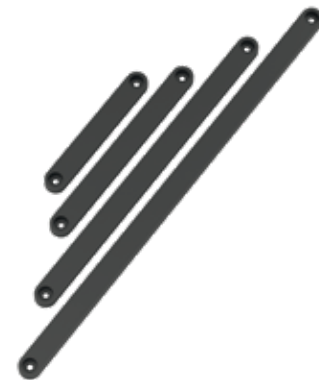

Order No.	Pattern	Length	Hole spacing	Width	Thickness
367500	100/100	166	142	25	12
367600	150/150	236	212	25	12
367700	250/250	378	354	25	12
367800	350/350	520	495	25	12

Quad

Cuboid rotatable adapters

Description

Cuboid rotatable adapters Enable e.g. cuboid columns or V-blocks to be mounted in a rotated position.

Material

Hard-coated aluminium.



Application example

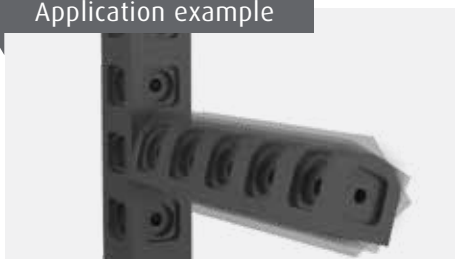

Order No.	Length	Width	Height	Weight
366500	25	25	25	0.04

Quad

Column connector, swivelling

Description

Swivelling connector for columns. To connect columns in a continuously adjustable angle.

Material

Hard-coated aluminium.

Contents

1 pair.



Application example



Order No.	Length	Width	Height	Version
363600	58	25	8	Swivelling

Quad

Cuboid adjustable mounting rails

Description

Adjustable rails for mounting cuboid elements or threaded columns.

Material

Hard-coated aluminium.



Application example



Quad

Order No.	Length	Width	Height	Adjustment range	Fig.
357800	83	25	12.5	38	1
366400	60	25	25	15	2

Cuboid X/Y positioning elements

Description

X/Y adjustment element for positioning cuboid elements outside the 25 mm grid pattern.

Material

Hard-coated aluminium.

Application example



Quad

Order No.	Length	Width	Height	Adjustment range
357500	65	65	25	15

Bushes and adapters

Description

Centring bush and plate for locating cuboid elements that are to be screwed together. Centring plate secured against rotation.

Material

Stainless steel.



Order No.	Description	Fig.
367000	Centring plate	1
367200	Centring bush	2

Quad

Adapter nut

Description

Adapter for fastening cuboid elements with M5 threads.

Material

Stainless steel.



Order No.	Description
367100	M5 adapter nut

Quad

Rail for support pins

Description

Adjustable rail for support pins.
Hole Ø4 mm / Slot width 6 mm.

Material

Hard-coated aluminium.



Application example

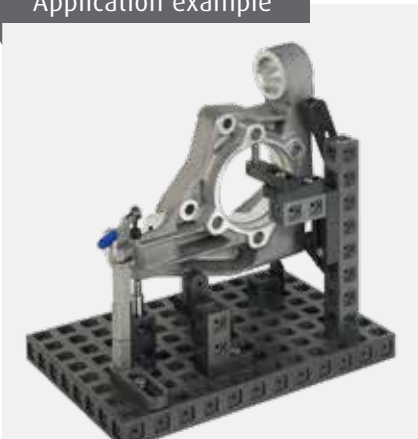

Order No.	Length	Width	Height	Adjustment range
357700	72	20	12	25

Adapter for support pins

Description

With Ø4 mm hole for support pins.
M5 or M6 connection thread.

Material

Stainless steel.



Order No.	Male thread	Female thread	Height	Fig.
356600	M 5	-	20	
356400	M 6	-	20	1
356700	-	M 5	20	2



Support pins

Description

Support pins and centre points for adapters and rails with $\varnothing 4$ mm holes.

Material

Stainless steel.

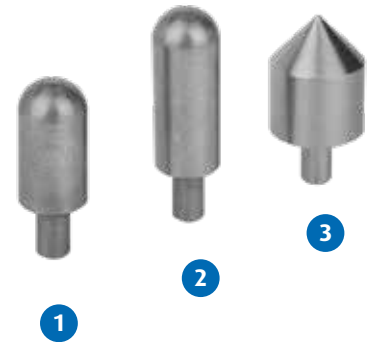

Application example



Order No.	Version	Diameter	Fig.
319400	R4 x 15 mm pin	8	1
319500	R4 x 20 mm pin	8	2
319300	90° centre point	12	3

Application example

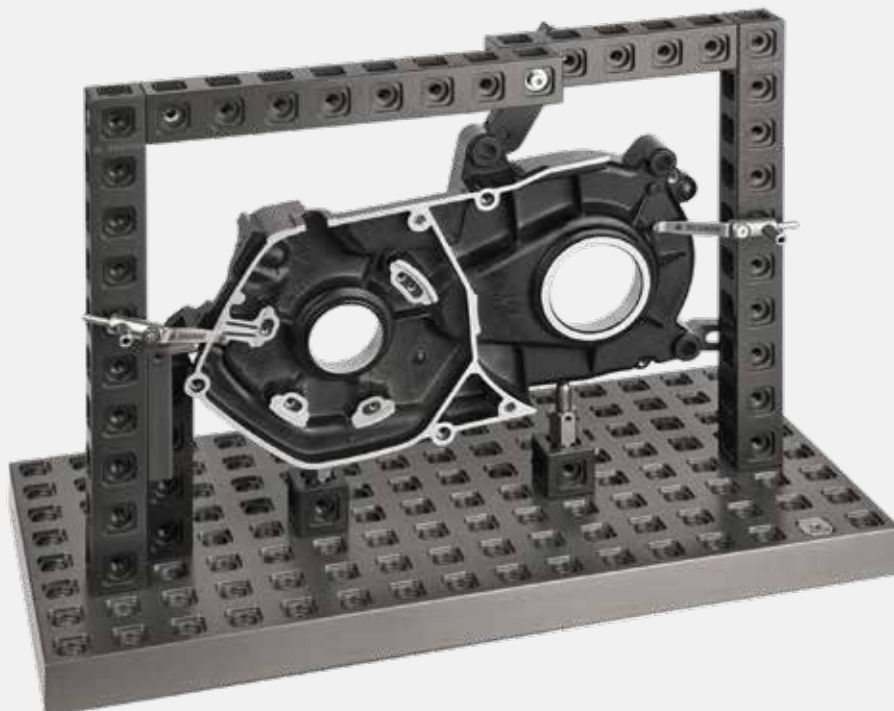

Hexagonal extensions M6

Description

M6 extension pieces for screwing directly onto baseplates or onto cuboid columns. Hexagon 13 mm.



Order No.	Male thread	Female thread	Length
322250	M 6	M 6	15
322350	M 6	M 6	25
322450	M 6	M 6	50

Jack screws M6

Description

Height adjustable supports. The M6 thread enables screwing directly into baseplates, horizontally into cuboid columns or joining to M6 hexagonal extensions.



Order No.	Version	Length	Fig.
322750	R3 mm ball-end	40	1
323050	self-aligning pad, steel, +/- 10°	35	2
323060	self-aligning pad, plastic, +/- 10°	35	
323070	Ø6 mm 5 N magnetic pin	42	3

Application example

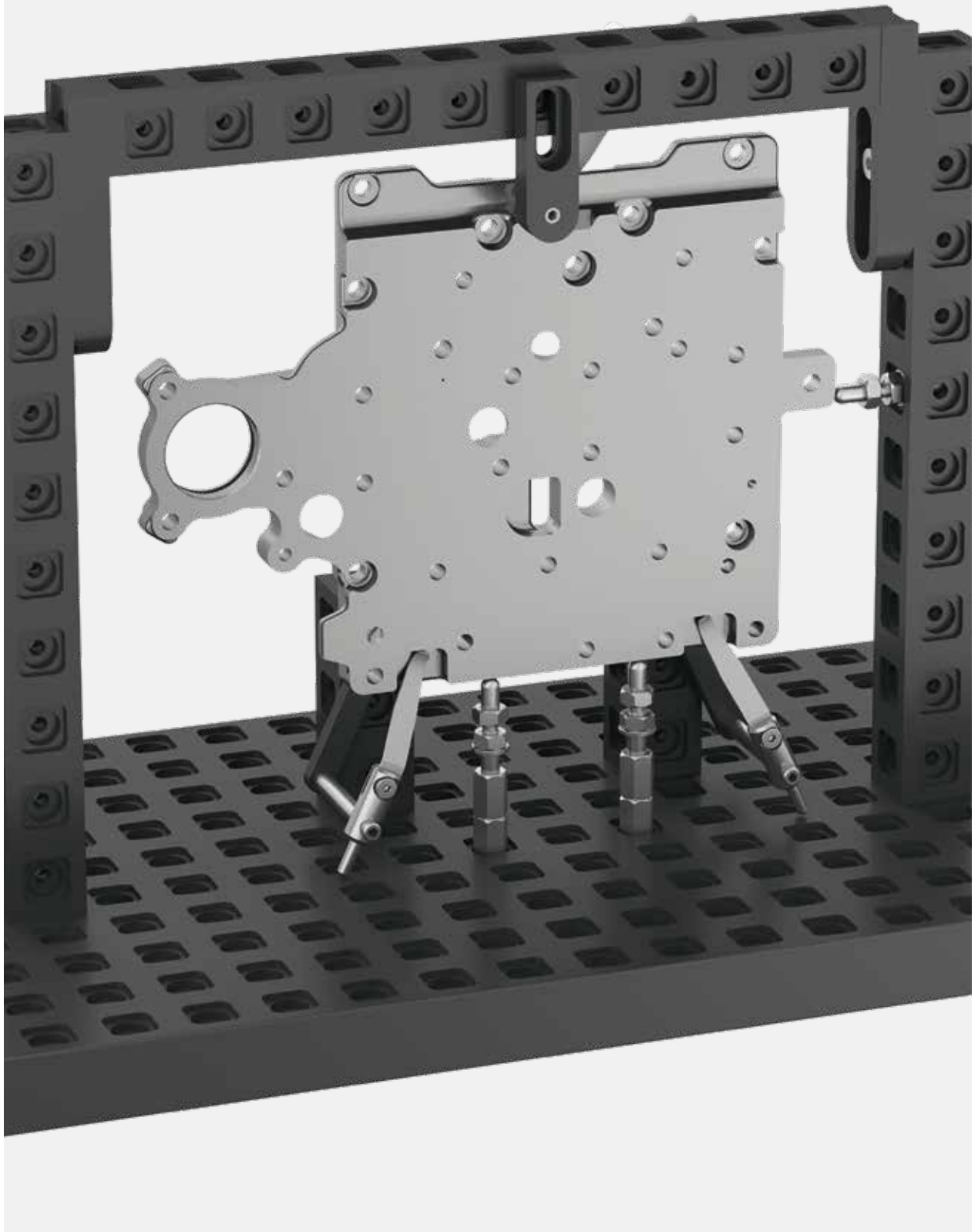

Base rails M 10

Description

Adjustable base rail with slot and M10 thread for mounting M10 extension pieces.

Material

Hard-coated aluminium.

Supplied with

M6 screw.



Order No.	Slot width	Adjustment range	Length	Width	Height
322010	6	60	105	25	12

M 10	M 10
M ...	T-Nut

Thread reducer extension piece

Description

Adapter element with centring ring for cuboid elements.

Material

Stainless steel.



Order No.	Connection 1	Connection 2	Length
369000	Male M 5	Female M 6	12
369200	Male M 5	Female M 8	28
356200	Male M 5	Female M 10	39
369100	Male M 6	Female M 8	28
356000	Male M 6	Female M 10	39
356300	Female M 5	Female M 10	30

M ...
Quad

Hexagonal extensions M10

Description

Hexagonal extension pieces with male thread one end and female thread other end. For screwing onto thread reducers and base rails to incrementally raise the height. Width across flats 17 mm.

Material

Stainless steel.



Order No.	Male thread	Female thread	Length
322200	M 10	M 10	25
322300	M 10	M 10	35
322400	M 10	M 10	50
304400	M 10	M 10	100
253500	M 10	M 10	150

M 8

M 10

Application example



Self-aligning pads M10

Description

Support with flattened, swivel ball to compensate for surface irregularities. Can be screwed onto hexagonal extension pieces or directly into base rails.

Material

Stainless steel/black oxidised steel.

Supplied with

Locknut.



Order No.	Support	Swivel range	Adjustment range	Length
323000	Ø 8	± 15°	15	46

M 10

Jack screws M 10

Description

Height adjustable supports for centring and supporting test parts.

Material

Stainless steel.

Supplied with

Locknut.



Order No.	Version	Adjustment range	Length	Fig.
322600	90° cone point, Ø10	15	50	1
322700	R5 mm ball-end	25	63	2

M 10

M 10 quick-change mount

Description

Quick-change adapter M 10 for SWA 5 / SWA 8 modules.

Material

Stainless steel.

Supplied with

Locknut.



Order No.	Version	Adjustment range	Length
329400	SWA 5	25	55
329500	SWA 8	25	57

SWA 5	SWA 8
M 10	M 10

Accessories

+ Centre points

Description

90° centre points with SWA 8 quick-change mount.

Material

Hard-coated aluminium.

Order No.	Diameter	Height	Fig.
303600	15	20	1
303700	25	20	2
303800	40	24	3

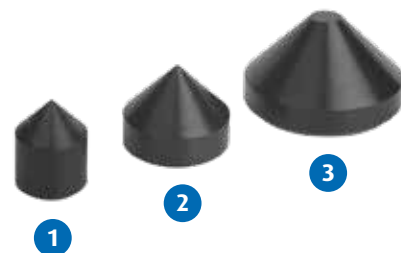

SWA 8

+ Prism supports

Description

120° prism supports with SWA 8 or SWA 5 quick-change mount.

Material

Hard-coated aluminium.

Order No.	Clamping range	Prism length	Connection	Height	Fig.
323500	Ø 2-60	8	SWA 8	35	1
323400	Ø 2-60	40	SWA 8	33	2



SWA 5 SWA 8

Accessories

+ Flat supports

Description

Flat supports in various versions: flat face, straight step and prism step. With SWA 8 quick-change mounts.

Material

Hard-coated aluminium.



Order No.	Version	Diameter	Height	Step height	Fig.
303805	Flat face	25	20		1
303810	Straight step	25	20	5	2
303815	Prism step	25	20	5	3

SWA 8

Screw jack set with spring finger

Description

Adjustable base rail with support and spring finger. The support height is adjustable.

Material

Hard-coated aluminium/stainless steel.

Supplied with

Base rail (322010), extension piece (322200), jack screw (322700), adapter plate for columns (353700), column with screw (368300), spring finger (302800), locknut and M6 fastening screw.

See T-slot nuts page 108 for fastening the base rail in a T-slot.



Order No.	Adjustment range	Length	Width	Support height
322005	60	105	25	80-90

M 6 T-Nut

Cuboid stops

Description

Stops for cuboids. Fixed or adjustable versions with ball support.

Material

Hard-coated aluminium/steel.



Order No.	Version	Adjustment range	Fig.
366600	Fixed	15 mm rail	1
366700	Adjustable	15 mm rail, 20 mm stop	2

Quad

Application example

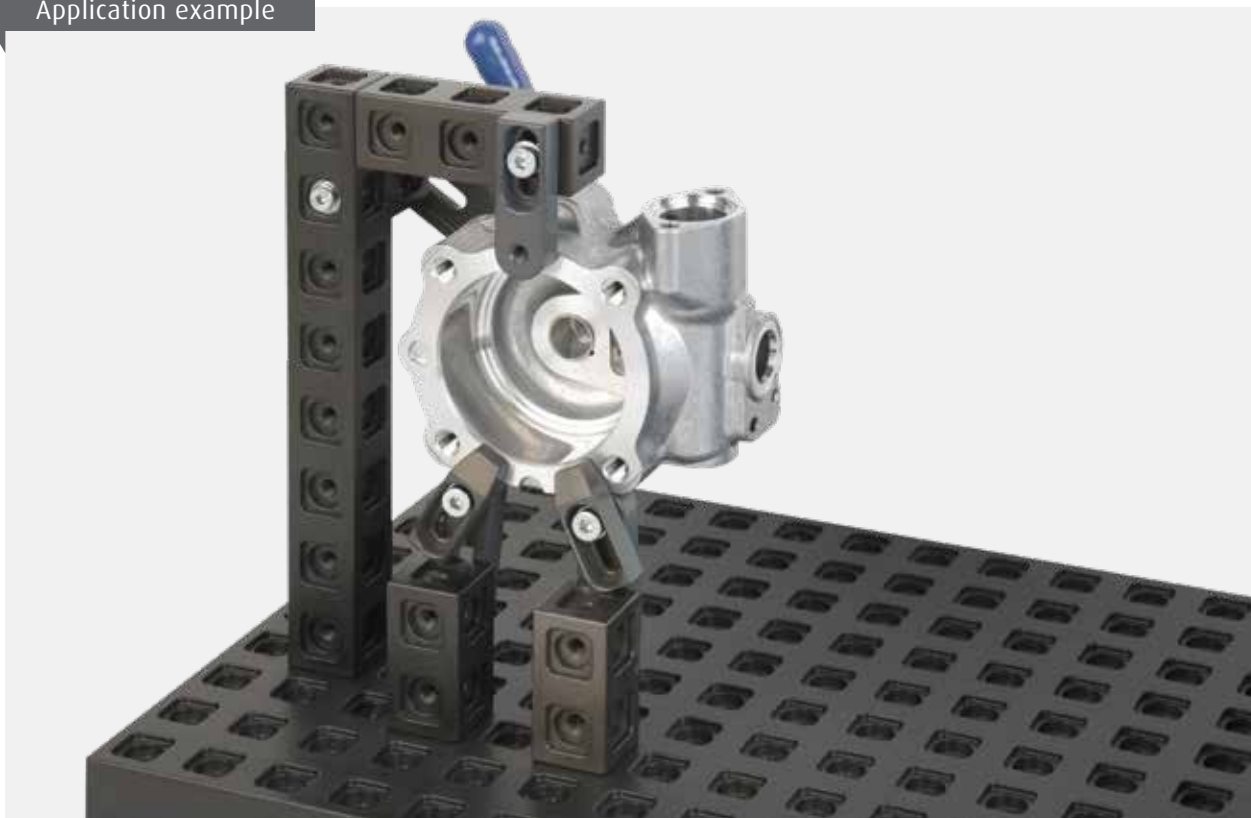

Spring fingers

Description

For the simple and quick holding down of workpieces.
Self-locking on round columns due to the applied tension by manually pressing down.

Material

Stainless steel.



Application example

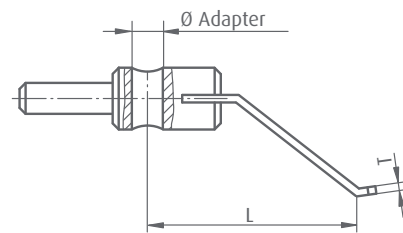

Order No.	Adapter Ø	Version	T	L	Fig.
302750	6	Round	1.1	50	
302760	6	Round	1.5	50	
302800	6	Flat	1	50	1
302900	6	Flat	1	75	
302810	6	Flat	1	90-125	2
302910	6	Flat	1	115-150	
302300	12	Flat	1	75	3
302400	12	Flat	1	95	
302320	12	Flat	1	120-150	
302500	12	Flat	1.5	75	
302600	12	Flat	1.5	95	
302520	12	Flat	1.5	120-150	
302350	12	Round	2.5	80	4
302340	12	Round	3	80	
302510	12	Forked	1.5	75	5
302610	12	Forked	1.5	95	

Columns with screw

Description

Columns with threaded connection for mounting spring fingers or for use as a stop element.

Material

Stainless steel.



Application example

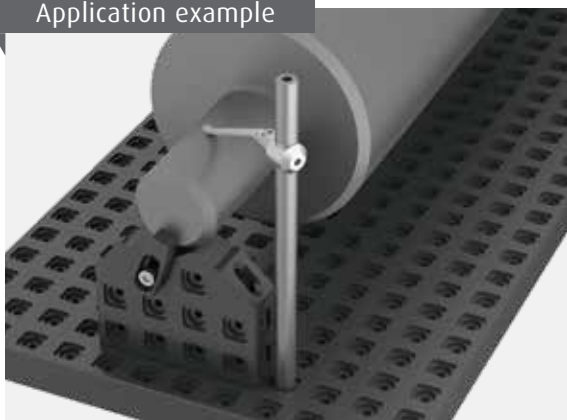

Order No.	Column Ø	Thread	Length
368100	6	M 6	30
368120	6	M 8	30
368200	6	M 6	50
368220	6	M 8	50
368300	6	M 6	75
368400	6	M 6	100
368500	6	M 6	125
368505	6	M 6	150
368600	12	M 6	50
368620	12	M 8	50
368700	12	M 6	100
368720	12	M 8	100
368800	12	M 6	150
368820	12	M 8	150
368900	12	M 6	200
368920	12	M 8	200
368610	12	M 10	50
368710	12	M 10	100
368810	12	M 10	150
368910	12	M 10	200

M ...

Adapter plates for columns

Description

Adapter plates for columns with M6 threads (e.g. for spring fingers) for mounting on M10 hexagonal extension pieces, self-aligning pads, rest pins and quick-change adapters.

Material

Stainless steel.



Order No.	Hole	Overhang
353700	Ø 10	50
353800	Ø 10	72

Application example

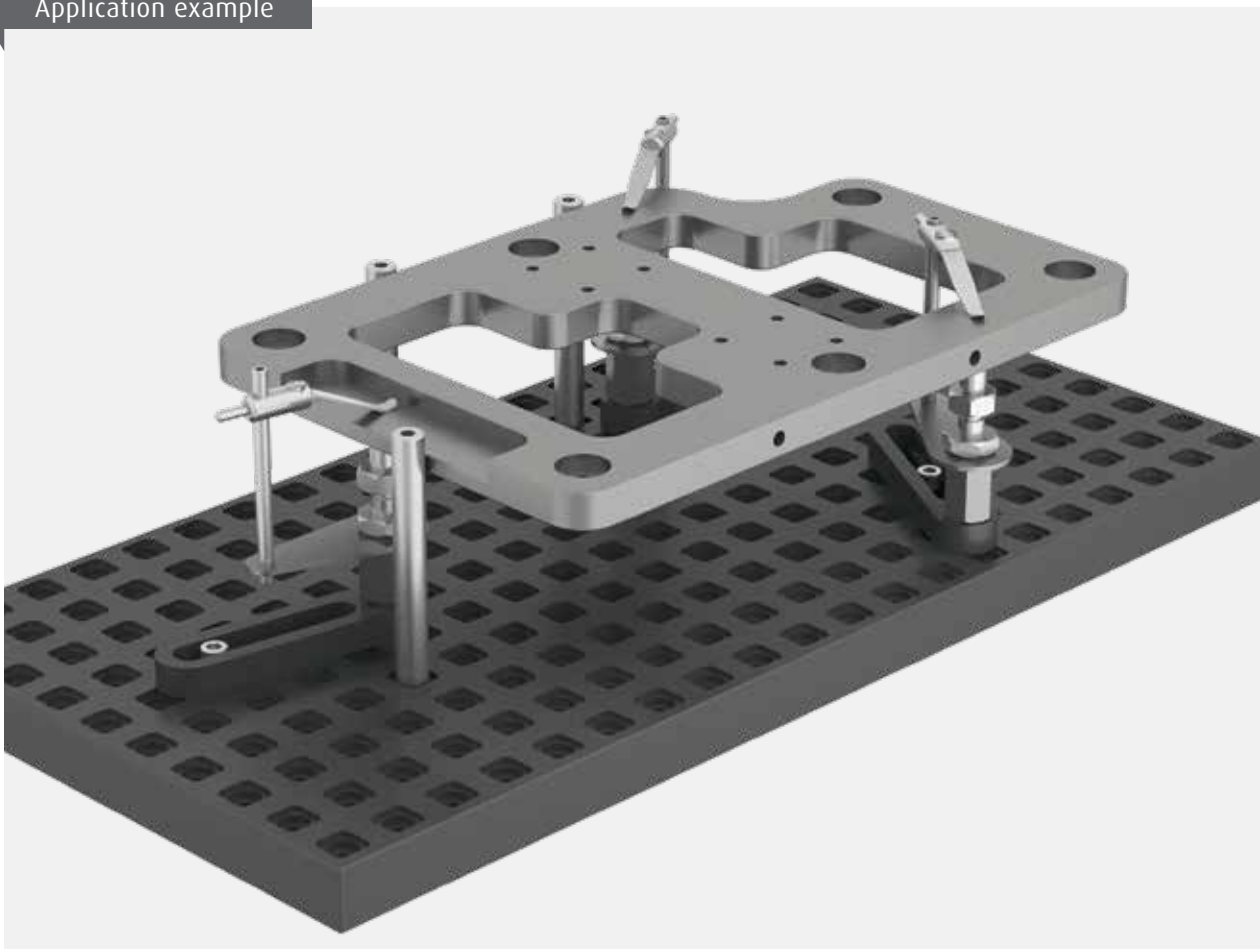

Toggle clamps with support

Description

Toggle clamp with support and M10 thread.

Supplied with

Locknut.



Application example



Order No.	Overhang	Clamping range	Height
336300	32	0-20	100
336400	51	0-27	115

M 10

Application example



Toggle clamp (used without support) with workpiece.

T-slot / Cuboid adapter

Description

Adapter for mounting cuboid modules on Spannfix T-slot plates.

Material

Aluminium/steel.

Supplied with

T-slot nut.



Application example



Order No.	Length	Width	Height	Weight
366300	50	25	35	0.09

Quad
T-Nut 6

Application example

With this interface, *QUADERFIX* components can be mounted onto *SPANNFIX COMPONENTS*.



SWA 39 quick-action clamp for QUADERFIX

Description

SWA 39 quick-action clamp for direct fastening on cuboid plates.

Material

Hard-coated aluminium.

Supplied with

Fastening screw.



Order No.

Height

362900

21.5

SWA 39
Quad

Application example

With this interface, quick-change SWA 39 components can be mounted onto the QUADERFIX system.



Quaderfix basic sets

Description

Set with various cuboid elements for mounting medium-sized test parts. The basis is formed by a 500 mm x 250 mm or 600 mm x 300 mm baseplate.

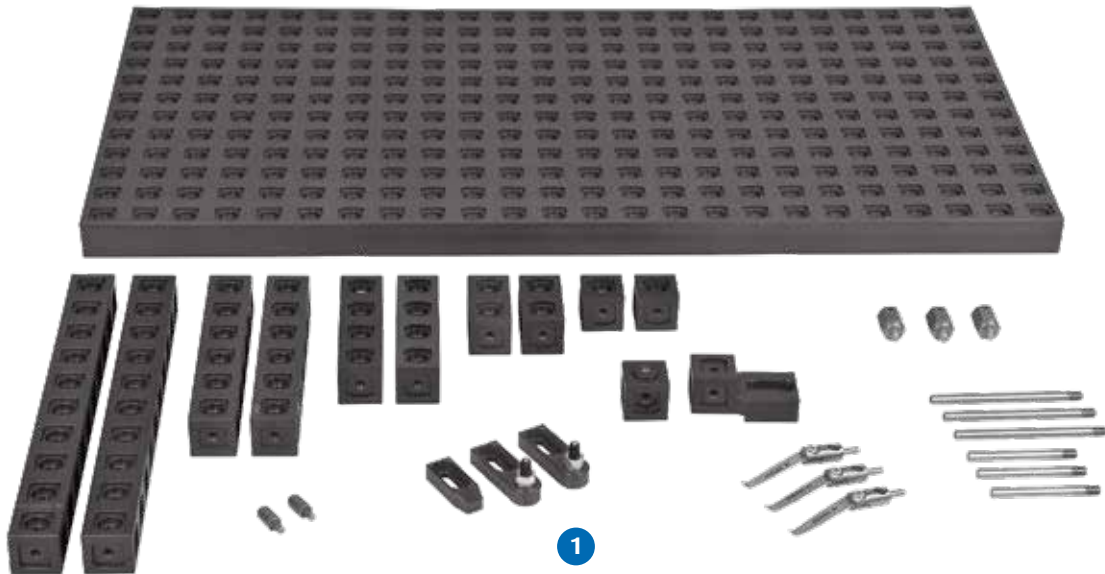

* Fasteners not shown.

Application example

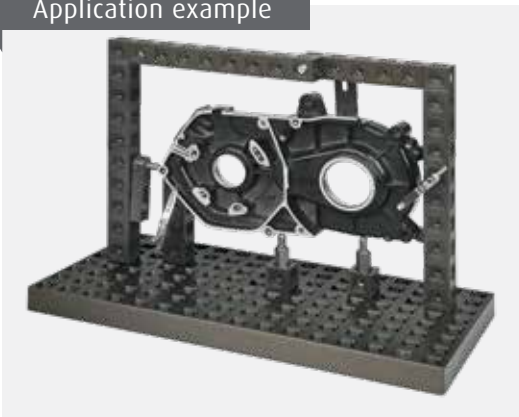

Set versions

Order No.	Description	Baseplate	Fig.
369915	Quaderfix basic set "1"	500 x 250	
369920	Quaderfix basic set "2"	600 x 300	1

Set contents

Order No.	Description	Set "1"	Set "2"
362000	500 x 250 mm cuboid baseplate	1	-
362100	600 x 300 mm cuboid baseplate	-	1
364700	250 mm cuboid columns	2	2
364500	150 mm cuboid columns	2	2
364300	100 mm cuboid columns	2	2
364100	50 mm cuboid columns	2	2
364000	25 mm cuboid columns	2	2
366500	Cuboid rotatable adapters	1	1
366400	Cuboid adjustable mount	1	1
366700	Cuboid adjustable stop	2	2
366600	Cuboid fixed stop	1	1
368200	50 mm columns for spring fingers	3	3
368300	75 mm columns for spring fingers	3	3
302800	50 mm spring finger	3	3
356600	M5 adapter for support pins	2	2
356400	M6 adapter for support pins	1	1
319400	R4 x 15 mm support pin	3	3
369800	Quaderfix fastener set "1"	1	1

Application example

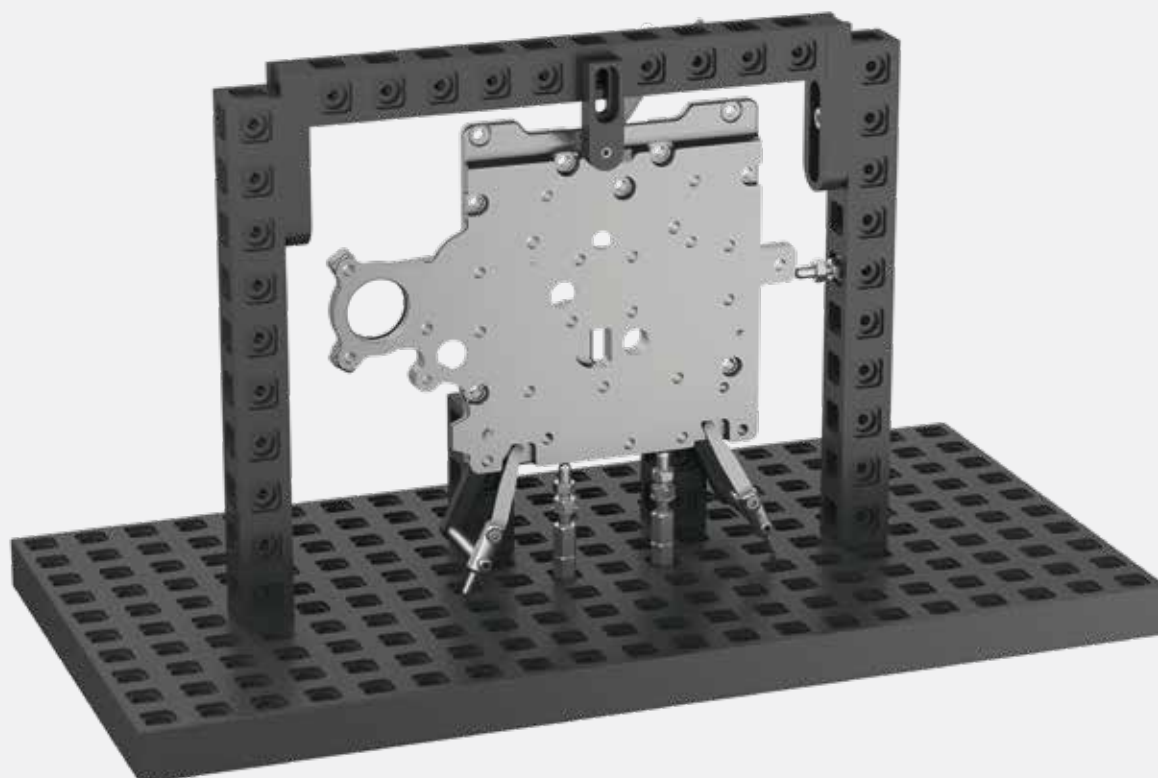

Quaderfix expansion set

Description

Expansion set with further Quaderfix modules for assembling more complex clamping fixtures.



Set versions

Order No.	Description
369930	Quaderfix expansion set

Set contents

Order No.	Description	Quantity
364700	250 mm cuboid column	1
364600	200 mm cuboid column	2
364500	150 mm cuboid column	1
364400	125 mm cuboid column	1
364300	100 mm cuboid column	1
364100	50 mm cuboid column	1
364000	25 mm cuboid column	1
366500	Cuboid rotating adapter	2
366400	Cuboid adjustable mount	1
366700	Cuboid adjustable stop	1
366600	Cuboid fixed stop	1
359700	Pair of cuboid 90° inverted V-blocks, 50 mm	1
359400	Pair of 120° cuboid V-blocks, 100 mm	1
368400	100 mm columns for spring fingers	3
302800	50 mm spring finger	1
302900	75 mm spring finger	2
356600	M5 adapter for support pins	1
356400	M6 adapter for support pins	2
357700	Rails for support pins	2
319500	R4 x 20 mm support pins	3
319300	90° centre point for support pins	3

Quaderfix fasteners

Description

Fasteners for Quaderfix in a practical assortment box. Consisting of i.e. bushes, adapters and clamping screws in various lengths, for mounting individual cuboid elements. Two set versions available.



Set versions

Order No.	Description	Fig.
369800	Quaderfix fastener set "1"	1
369900	Quaderfix fastener set "2"	

Set contents

Order No.	Description	Set "1"	Set "2"
367000	Centring plates	10	20
367100	M5 tapped bushes	5	10
367200	Centring rings	5	10
369100	Thread reducers - male M6 / female M8	-	2
369200	Thread reducers - male M5 / female M8	-	1
	Screws M5 x 14	15	30
	Screws M5 x 16	15	30
	Screws M5 x 30	15	30
	Screws M5 x 45	10	20
	Screws M6 x 12	15	30
	Screws M6 x 16	15	30
	Screws M6 x 20	15	30
	Screws M6 x 25	15	30
	M5 washers	40	40
	M6 washers	40	40
	2.5 mm hexagonal key	-	1
	3 mm hexagonal key	-	1
	4 mm hexagonal key	-	1

SCHIENENFIX

Clamping system for optical and multi-sensorial measuring

- » Modular clamping elements for optical or optical/tactile measuring
- » For high-precision edge measurement in reflected and transmitted light
- » Toothed rails as workpiece rests or for fastening clamping modules
- » For optical/tactile measuring machines, measuring projectors and measuring microscopes

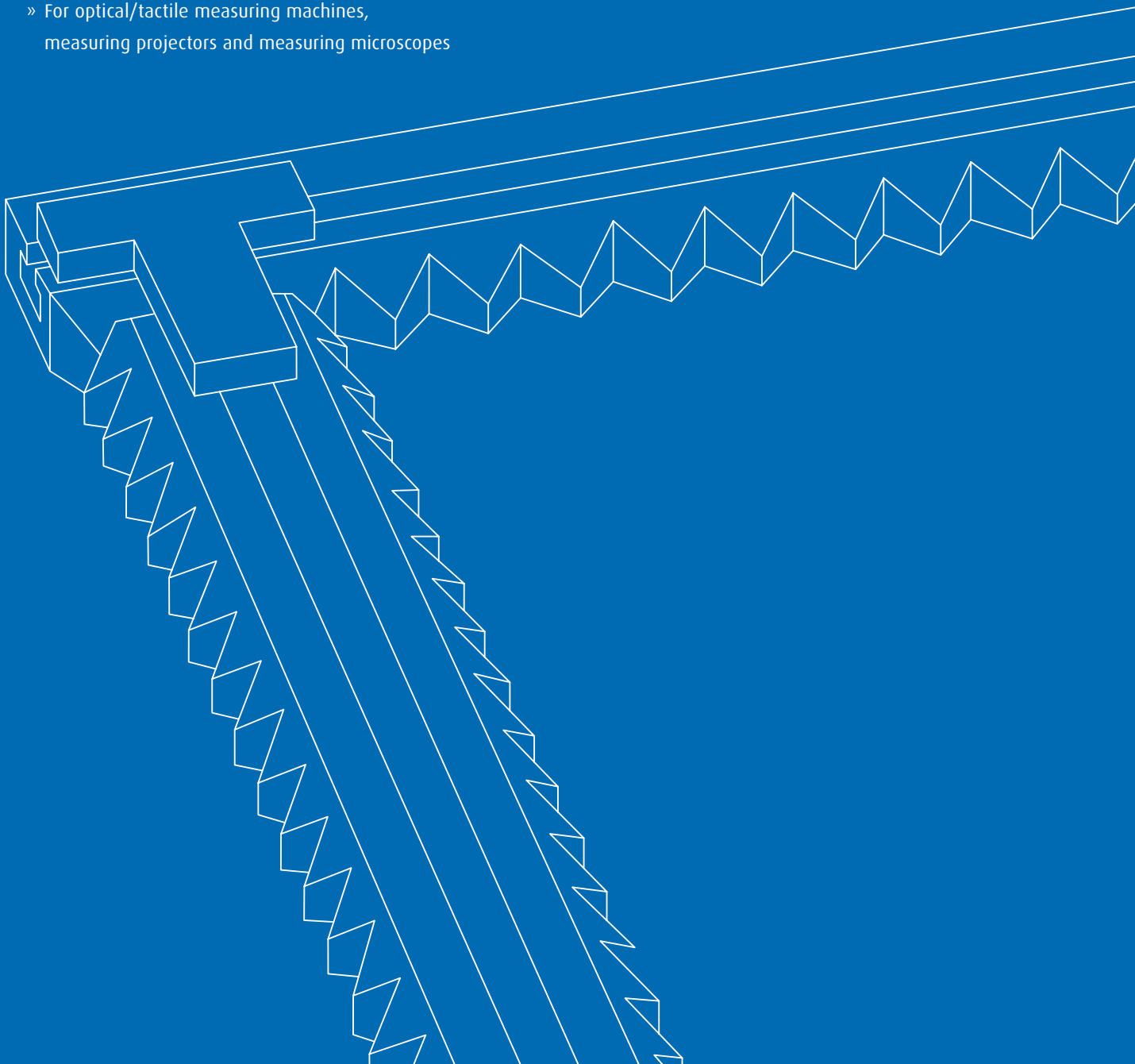

Basic elements
+ accessories



Base rails

Page 228



Connecting rails

Page 229



Rail connecting adapters

Page 230



T-slot nuts and screws

Page 230



Clamping claws

Page 231



Clamping elements

Page 232



Base mount

Page 233



Quick-action clamp

Page 234



Quick-action clamp 90° angle element

Page 235



90° angle element

Page 235

Structural elements
+ accessories



Articulated arms

Page 236



Satellite mount

Page 236



Rotary unit

Page 237



SWA 5 quick-change mount

Page 238



Rotary unit with fine adjustment and indexing

Page 239



Quick-change pallet system

Page 240

Clamping elements
+ accessories



Spring finger for horizontal clamping

Page 242



Spring finger for vertical clamping

Page 243



Square columns for spring finger

Page 243



SWA 5 spring finger for vertical clamping

Page 245



Spring finger with fastener

Page 245



Spring clamp for vertical clamping

Page 244



Stop set

Page 246



Rest angle with spring finger

Page 247



Small screw jack set

Page 248



Small screw jack set with spring finger

Page 248



Toggle clamp for toothed rails

Page 251



15 mm precision vice

Page 252



25 mm precision vice

Page 254



35 mm precision vice

Page 255



50 mm precision centric vice

Page 256



50 mm precision vice

Page 257



50 mm precision vice

Page 258



Clamping elements
(continued)



V-block with spring finger
Page 262



V-block with magnetic prism
Page 262



V-block bracket
Page 263



V-blocks
Page 264



Mini tailstock
Page 266



Tailstock
Page 268



Dividing head
Page 270



Precision mini chuck
Page 274



34 mm precision three-jaw chuck
Page 275



50 mm precision three-jaw chuck
Page 276



65 mm precision three-jaw chuck
Page 277



Small-parts clamp, stepped jaw
Page 278



Small-parts clamp, smooth
Page 279



Small-parts clamp with prism jaw
Page 280



Small-parts clamp with screw tightener
Page 280



Stop for small-parts clamps
Page 281



U-clamp
Page 281



Magnet
Page 282



Parallel clamps
Page 283

Other clamping elements
+ accessories



Multispannfix
Page 284



Nadelfix 2.5
Page 286



Inspection vice
Page 287



Four-way hexagon key
Page 287

Sets



Schienenfix basic sets

Page 288



Schienenfix expansion sets for turned parts

Page 290



Schienenfix expansion sets for milled and plate parts

Page 291

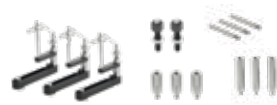

3-point support set

Page 292



Pallets with clamping elements

Page 293



Universal clamping sets

Page 294



Clamping component sets

Page 296

Perfect modularity for optical and multi-sensorial measuring with zero-point referencing

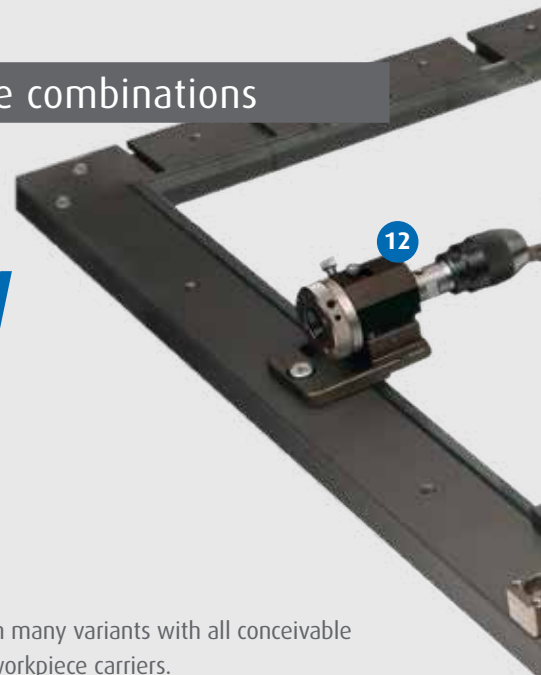

The outstanding advantages begin with the simplest toothed rail angle rests:

- Wide or fine tooth pitch as a secure yet virtually transparent unit for easy edge measurement
- Standard tooth pitches for precise repeat aligning of parts or structural elements
- Integrated T-slot for redesigning the rest angle or expansion to more complex base rail layouts
- T-slot as a mount for a wide range of attachable base, structural, adjustment, support and clamping elements

"Fast Reassembly Lifelong" also and particularly applies to *SCHIENENFIX*, which not only fully integrates the *SWA39* parts via standard interfaces, but also offers interfaces for the *SWA5* and *SWA8* quick-change adapter systems. dk only supplies rigid angles milled from solid material or Plexiglas plates with tapped holes if very special parts require them or if special processes are improved by them. Interchangeable pallet systems to set-up outside the machine for measuring other identical or completely different test parts are available

in many variants with all conceivable workpiece carriers.

dk *FIXIERSYSTEME* developed and standardised these efficient interchangeable systems as part of the *SPANNFIX* range from the conception of optical measurement technology.

Basic elements

- 1 Base rails (page 228)



- 2 Connecting rails (page 229)



- 3 Rail connecting pieces (page 230)



Structural elements

- 6 Clamping claws (page 231)



- 10 Quick-action clamp 90° angle element (page 235)



- 12 Rotary swivel mount (page 239)



- 13 Thread adapter (page 206)



- 14 Articulated arm (page 236)



Other accessories (page 237)



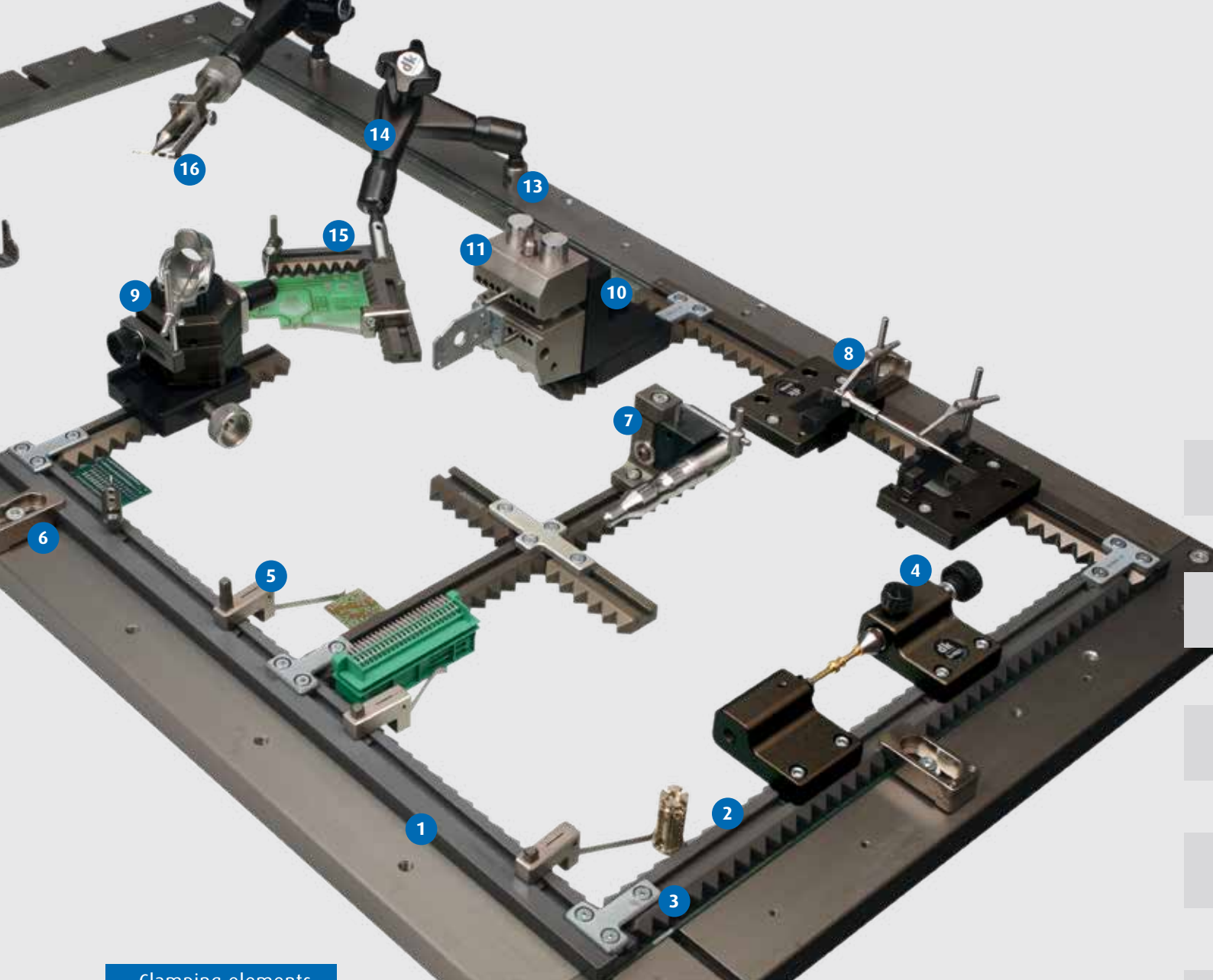

Clamping elements

- 4 Mini tailstock (page 266)
Other accessories (pages 26 & 269)



- 5 Spring finger for horizontal clamping (page 242)



- 7 V-block bracket (page 263)



- 8 V-blocks (page 264)



- 9 Nadelfix 2.5 (page 286)



- 11 50 mm precision vice (page 257)



- 15 Stop angle with spring finger (page 247)



- 16 Small-parts clamp, stepped jaw (page 278)



FAST REASSEMBLY LIFELONG

The basic principle of all dk fixing systems. The compatibility of the dk programs makes the utility value perfect.

Base rails

Description

Single-side toothed rail with T-slot. To use as a rest or for mounting modular structural and clamping elements. With 5 mm or 10 mm tooth pitch.

Material

Hard-coated aluminium.

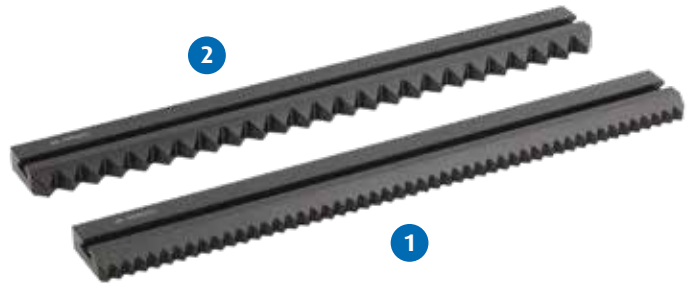

Order No.	Tooth pitch	Length	Width	Height	Fig.
344920	5	200	28	10	
345020	5	250	28	10	1
345220	5	350	28	10	
345420	5	450	28	10	
345620	5	500	28	10	
344900	10	200	28	10	
345000	10	250	28	10	2
345200	10	350	28	10	
345400	10	450	28	10	
345600	10	500	28	10	
2999XX	5 or 10	acc. to customer specs.		10	

T-Nut 5

Application example

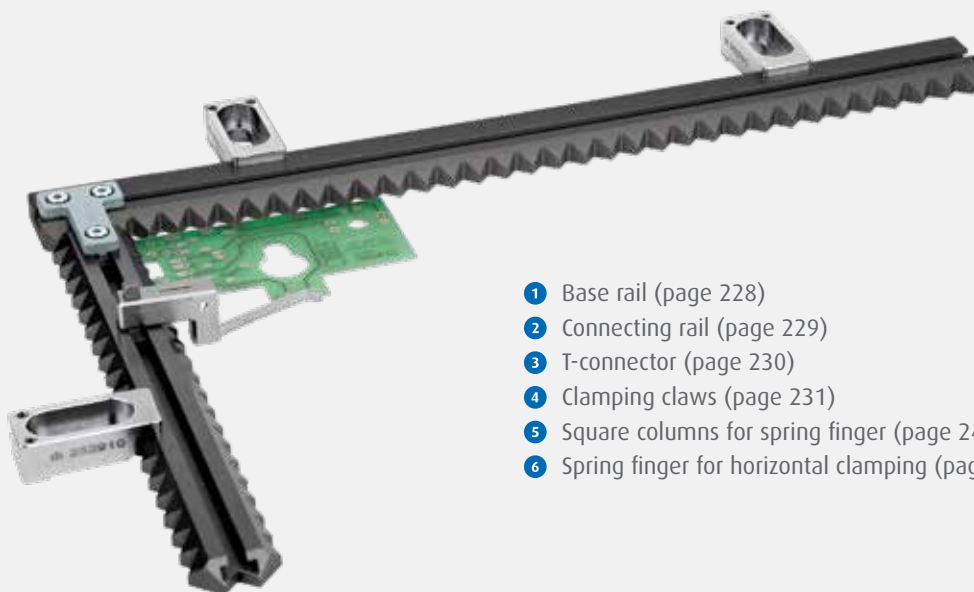

- 1 Base rail (page 228)
- 2 Connecting rail (page 229)
- 3 T-connector (page 230)
- 4 Clamping claws (page 231)
- 5 Square columns for spring finger (page 243)
- 6 Spring finger for horizontal clamping (page 242)

Connecting rails

Description

Rails with T-slot to use as a rest or for mounting modular structural and clamping elements. Connecting rails, toothed on 2 long sides and one end face. Rails toothed all 4 sides can also be used as connecting rails between 2 other rails. Angle or frame constructions also possible as a combination of different tooth pitches.

Material

Hard-coated aluminium.

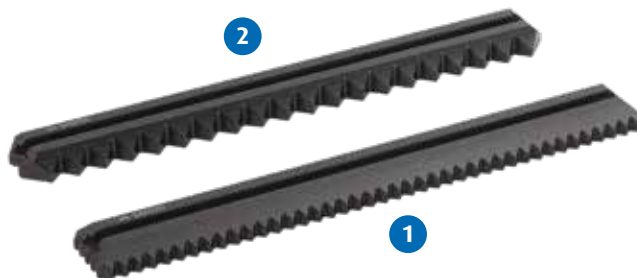

Order No.	Grid	Tooth pitch	Length	Width	Height	Fig.
347020	3	5	60	28	10	
347220	3	5	100	28	10	
347420	4	5	150	28	10	
346020	4	5	200	28	10	1
346220	4	5	250	28	10	
346420	4	5	350	28	10	
346620	4	5	400	28	10	
347000	3	10	60	28	10	
347200	3	10	100	28	10	
347400	4	10	150	28	10	
346000	4	10	200	28	10	2
346200	4	10	250	28	10	
346400	4	10	350	28	10	
346600	4	10	400	28	10	

T-Nut 5

Application example

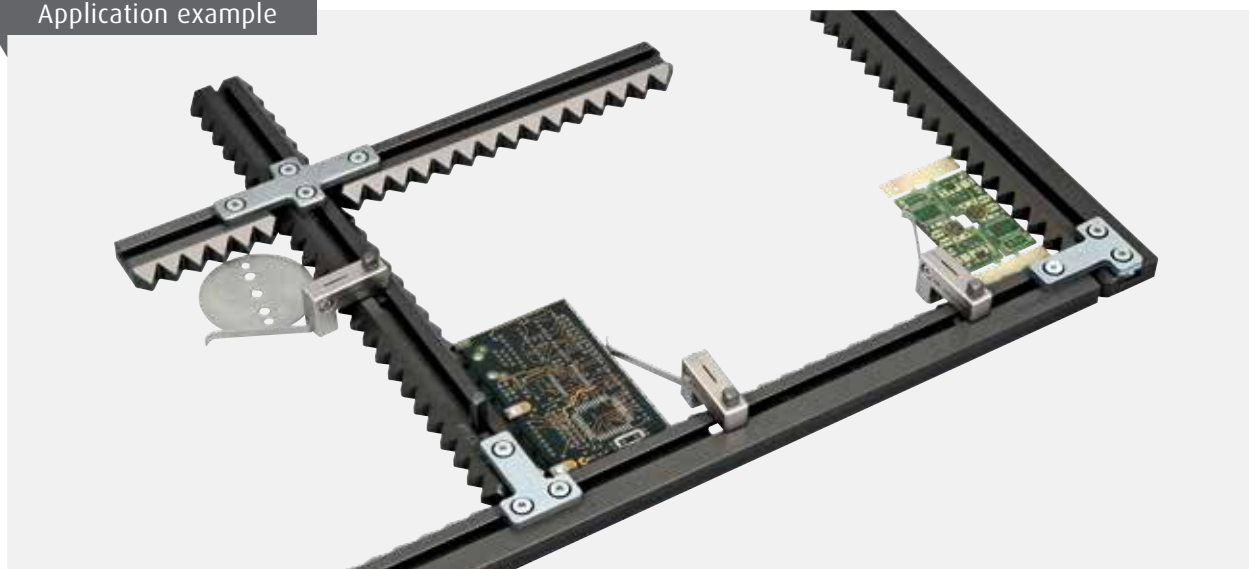

Rail connecting pieces

Description

Connecting piece for toothed rails.
Aligned and clamped in a T-slot.

Material

Hard-coated aluminium/steel.

Supplied with

T-slot nuts and fastening screws.



Order No.	Form	Length	Width	Height	Fig.
348000	T connector	28	40	3.5	1
348200	Cross connector	28	73	3.5	2

T-Nut 5

T-slot nuts and screws

Description

T-slot nuts and screws for clamping claws, fastening joints and satellite mounts.

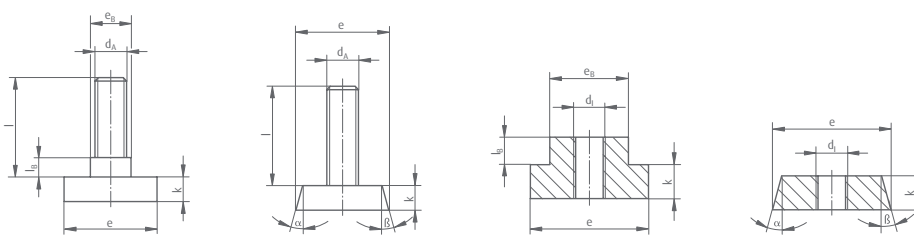

Order No.	dA	dl	e	eB	k	l	lB	α	β	Type
265300	M 5	-	10	-	2.5	14.5	-	-	-	I
265310	M 5	-	10	-	3	20	-	-	-	I
264100	M 5	-	11.8	-	2.8	15	-	-	-	I
265000	M 6	-	10.2	-	1.8	12	-	-	-	I
264600	M 6	-	11	-	4.8	16	-	-	-	I
264000	M 6	-	11.8	-	2.8	10.5	-	-	-	I
264800	M 6	-	15	7.9	7	15	5	-	-	I
347700	-	M 4	10	-	2.5	-	-	-	-	IV
264700	-	M 5	11	-	4.8	-	-	-	-	IV
265500	-	M 5	15	7.9	7	-	5	-	-	III

Clamping claws

Description

Clamping claw for clamping toothed rails to the measuring equipment table. Setscrews enable compensation for height differences of the glass plate. Different clamping claw lengths to match the distance between the measuring field on the machine and the mounting holes on the measuring table.



Supplied with

Fastening screws. When clamping in a T-slot, order T-slot nuts separately.

↳ See page 244 for T-slot nuts

Order No.	Length	Fastener/thread	Measuring field to hole centre
262910	35	no screw	35-55
262914	35	M 4	35-55
262915	35	M 5	35-55
262916	35	M 6	35-55
262918	35	M 8	35-55
262920	45	no screw	35-65
262924	45	M 4	35-65
262925	45	M 5	35-65
262926	45	M 6	35-65
262928	45	M 8	35-65
262940	60	no screw	60-80
262944	60	M 4	60-80
262945	60	M 5	60-80
262946	60	M 6	60-80
262948	60	M 8	60-80
262950	110	no screw	70-110
262954	110	M 4	70-110
262955	110	M 5	70-110
262956	110	M 6	70-110
262958	110	M 8	70-110

M ...

Application example



Clamping elements

Description

Fastening set for connecting toothed rails. Connecting rails can be secured in the T-slot of the lower rail using these clamps.



Application example



Order No.

Contents

349800

1 set of 2 clamps

T-Nut 5

Application example



Base mount

Description

SWA 39 quick-action clamp for the direct mounting of fixturing modules from the SWA 39 product range on measuring equipment tables. With slot for screws up to M6.

Material

Hard-coated aluminium.



Order No.	Length	Width	Height
263710	150	85	15

SWA 39
M ...

Application example

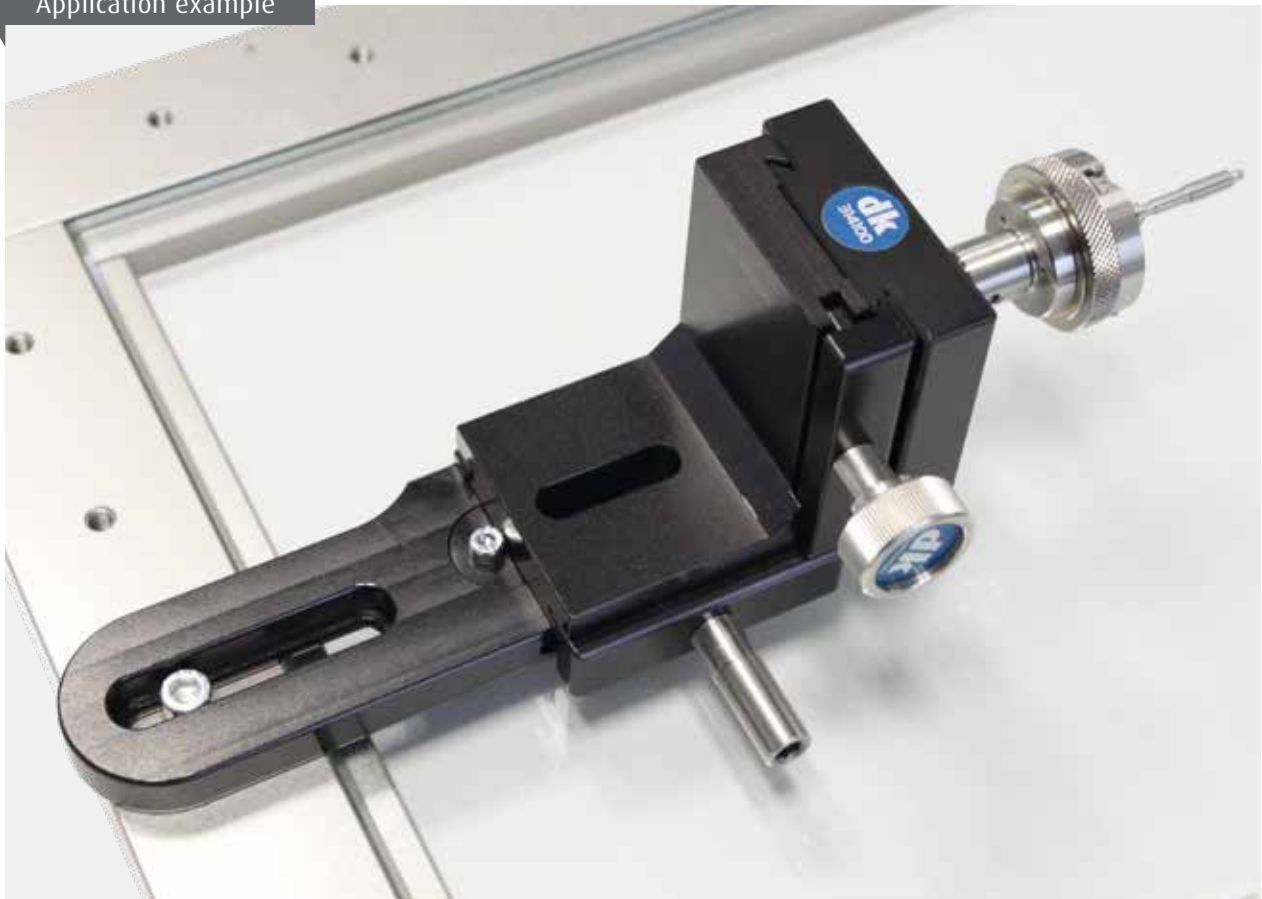

Quick-action clamp

Description

SWA 39 quick-change mount for mounting on toothed rails. Alignment on T-slots via centring pins in the base.

Material

Hard-coated aluminium/steel.

Supplied with

T-slot nuts.



Order No.	Length	Width	Height
273320	80	63	15

SWA 39
T-Nut 5

Application example



Quick-action clamp 90° angle element

Description

Quick-action clamp angle element for mounting clamping elements. The angle element is fitted to a quick-action clamp or can be fastened using screws up to M8.

Material

Hard-coated aluminium.



Application example



Order No.	Length	Width	Height
283300	60	90	48

SWA 39

SWA 39
M ...

90° angle element

Description

Angle element for mounting quick-action clamp 273320 from the SWA 39 product range. The angle element is mounted directly onto the toothed rail.

Material

Hard-coated aluminium.

↳ For quick-action clamp, see page 234.



Application example



Order No.	Length	Width	Height
273330	25	40	50

T-Nut 5

Articulated arms

Description

Progressive clamping articulated stands with a connection screw in the base and a quick-change adapter on the arm. Mechanical articulated arm. Central locking. Holding force at right angles 100 N (type MU) or 80 N (type SU).

For thread reducer for other thread sizes, see page 168.

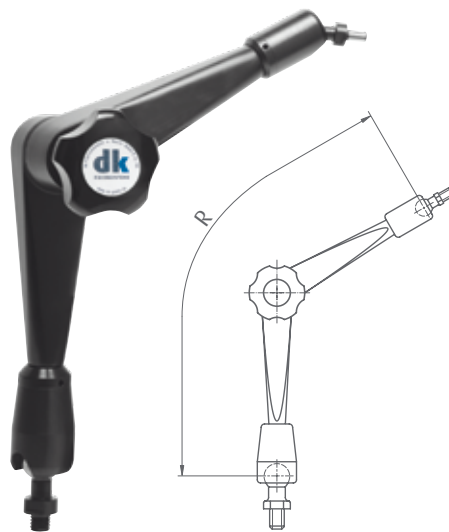

Application example



Order No.	Model	Thread	Adapter	Action radius (R)
296800	SU	M 8	SWA 5	160
296700	SU	M 8	SWA 8	160
296900	MU	M 10	SWA 5	280
297000	MU	M 10	SWA 8	280

SWA 8	SWA 5
M ...	M ...

Satellite mounts

Description

Adapter for mounting articulated arms on tables with slots or threads. This element enables the articulated arm to be position at a shallower angle.

Material

Stainless steel.

Contents

Supplied without T-slot nut.

For T-slot nuts, see page 230. Ordering information: include the thread size on your measuring equipment.



Application example



Order No.	Connection	Joint connection	For articulated arm	Mount
269700	M4-M8 or slot	M 8	SU	Horizontal

M ...	M ...
T-Nut	M ...

Rotary unit

Description

Attachment module that indexes every 90°. This module enables equipment such as small-parts clamps or magnetic V-blocks to be rotated and indexed every 90°.

Material

Stainless steel.



Application example



Order No.	Length	Connection 1	Connection 2
269600	30	SWA 5 female	SWA 5 male

SWA 5

Application examples



SWA 5/SWA 8 quick-change mount

Description

SWA 5 and SWA 8 quick-change mount. Mounted on quick-change clamp SWA 39 or T-slot nut for mounting in T-slots 5.

Material

Stainless steel.



Application example



Order No.	Length	Width	Height	Bottom adapter	Top connector	Fig.
314620	15	15	17	T-slot	SWA 5	1
314100	60	60	34	SWA 39	SWA 5	2
314200	60	60	34	SWA 39	SWA 8	2

SWA 5	SWA 5	SWA 8
T-Nut 5	SWA 39	SWA 39

Application example



Rotary unit with fine adjustment and indexing

Description

Free rotating spindle, indexing every 30° and can be clamped at any rotary angle. With SWA 5 connection for many clamping elements such as mini chucks and small-parts clamps. Position of increments and horizontal spindle position can be finely adjusted. Mounting on toothed rail or measuring table.

Material

Hard-coated aluminium/stainless steel.

Supplied with

T-slot nut and fastening screw for mounting on toothed rails. With operating tools



Application examples



Order No.	Centre height	Swivel	Weight
314900	25	± 15°	0.17

SWA 5 T-Nut	SWA 5 M ...
----------------	----------------

Application example



Quick-change pallet system

Description

Pallets with T-slot and M6 threads for mounting diverse clamping modules. For reproducible positioning the pallets can be set against a square and held there using spring fingers or toggle clamps. Can also be held magnetically using fixation set 345815.

Material

Hard-coated aluminium.

↳ Special sized versions available on request.



Order No.	Outer dimensions	Window dimensions	Version	Fig.
345801	305 x 100 x 10	200 x 72	Normal	1
345821	195 x 100 x 10	160 x 72	Short	2
345830	305 x 136 x 10	200 x 100	KY	
345815	Fixation set for magnetically holding pallets on toothed rail angles			3

T-Nut 5

M 6

Application example



Benefits of the quick-change pallet systems from dk

- Universal and mobile carrier plate
- Elements from the SWA 39, SWA 5 and SWA 8 systems can be mounted and positioned
- Improved metrology machine OEE through setup and fixating the test piece outside the machine
- Precise repeat positioning on the machine by using the rail system
- Rapid, tool-free positioning and fixation on dk rail systems using magnetic contacts or mechanically with spring fingers or toggle clamps
- Measuring table not occupied with permanently mounted clamping modules
- Durable aluminium hard-coat pallets instead of fragile acrylic glass
- no acrylic glass between test part and light source and thus no falsifying deflection of light by thread matrix and damage to the sensitive plastic surface
- Ideal utilization of the metrology machines together with the dk toothed rail system, which can be assembled in completely arbitrary geometries and also permits the placement of several pallets



Application examples

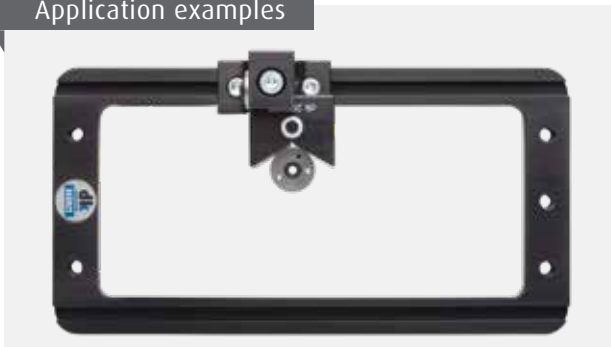

Spring fingers for horizontal clamping

Description

Spring fingers for clamping workpieces horizontally on toothed rails. Versions with different finger lengths and for right or left clamping. Small parts can be held in the angle corners using the bent finger versions. Lock effected by tilting the spring finger adapter (5 mm square).

Material

Brass/stainless steel.

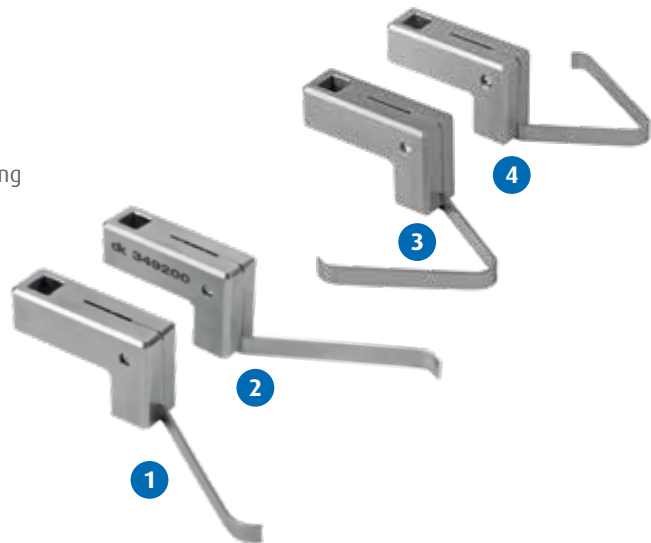

Application example

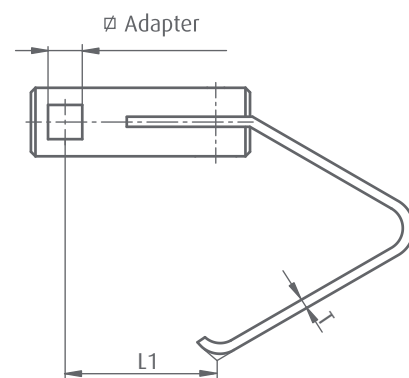
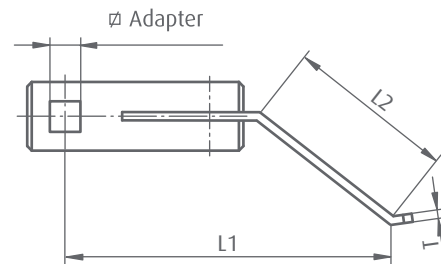

Order No.	Adapter square ∅	Clamping direction	T	L1	L2	Fig.
349100	5	Left	0.6	60	34	1
349200	5	Right	0.6	60	34	2
349300	5	Left	0.6	66	50	
349400	5	Right	0.6	66	50	
349150	5	Left	0.6	23	-	3
349250	5	Right	0.6	23	-	4

Spring fingers for vertical clamping - square column

Description

Spring finger for the vertical clamping of test parts on rail elements. Lock effected by tilting the spring finger adapter (5 mm square).

Material

Hard-coated aluminium/steel.

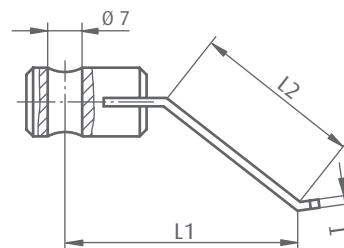
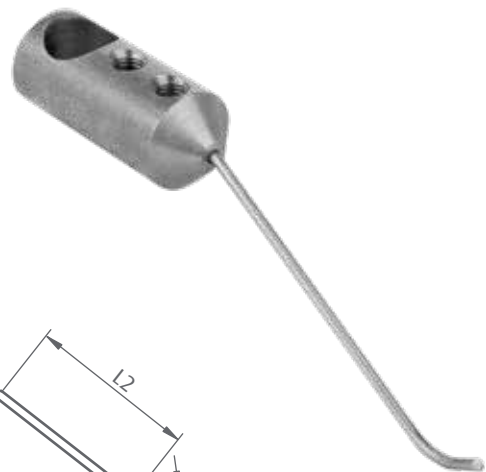

Order No.	Adapter \varnothing	Version	T	L1	L2
269100	5	Round	1.1	50	34
268100	5	Round	1.1	70	50

Square columns for spring fingers

Description

Clamping column (5 mm square) for mounting spring fingers. For T-slots.

Material

Hard-coated aluminium.



Application examples

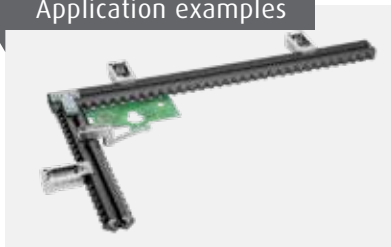

Order No.	Mount \varnothing	Length
268500	5	20
268600	5	30
268700	5	50

T-Nut

Accessories

+ Spring fingers for vertical clamping - round column

Description

Quick and easy holding of workpieces.

Material

Stainless steel

Order No.	Adapter Ø	Version	T	L
269037	4	Flat	0.4	30
343700	4	Flat	0.8	30
343710	4	Flat/narrow	0.8	30

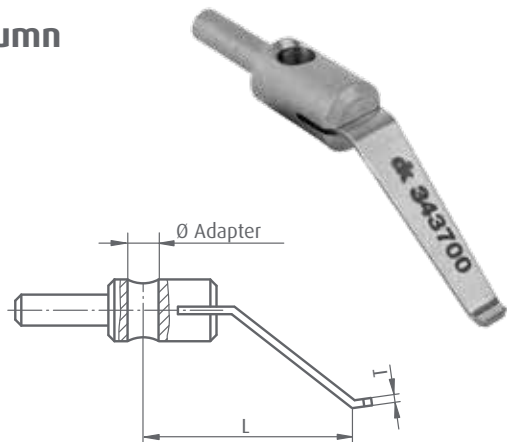

+ Columns for spring fingers

Description

Columns for mounting spring fingers.

Material

Stainless steel

Order No.	Column Ø	Thread	Length
269042	4	M 4	30
269043	4	M 4	50
269044	4	M 4	75



+ Slot key for spring fingers

Description

Slot key for mounting 4 mm round columns on slot rails and quick-change pallets of the Schienenfix range.

Material

Stainless steel



Application example



Order No.	Suitable for	Thread
347700	T-slot 5	M 4

Spring finger for vertical clamping – SWA 5

Description

Spring fingers with SWA 5 quick-change mount.
The spring fingers clamp can be flexibly positioned using an articulated arm.

Material

Stainless steel.

Application example

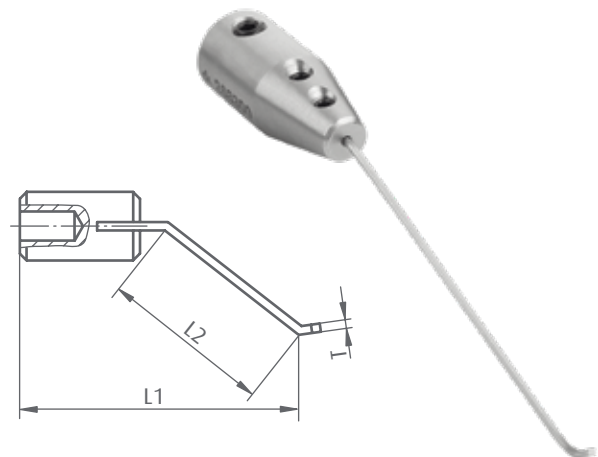

SWA 5

Order No.	Adapter Ø	Version	T	L1	L2
269300	SWA 5	Round	1.1	60	34
268300	SWA 5	Round	1.1	75	50

Spring finger with fastener

Description

Spring finger with mount for toothed rails. Columns with M4 threads can be mounted vertically or horizontally on the holder.

Material

Aluminium/stainless steel.

Supplied with

Spring finger (343700), column (269043) and column holder (347900).

↳ For other spring fingers, see the "Spannfix" section on page 59 or for columns with other lengths see page 60.



Application examples



T-Nut 5

Order No.	Length	Width	Height
267915	90	12	14

Stop set

Description

The stop teeth are located on the toothed rails and can be positioned anywhere along the T-slot. Complex parts can be positioned securely and reproducibly with three point of contact. The stop teeth are available in two lengths.

Material

Hard-coated aluminium/stainless steel.

Supplied with

3x stop teeth and 3x connectors (348100).



Order No.	Tooth length	Version	Fig.
347500	30 mm	Aluminium	1
347510	50 mm	Aluminium	

Application example



Rest angle with spring clamp

Description

Toothed rail angle with T-slot and two spring fingers for holding small parts. With the integrated quick-change interface SWA 5, the angle can be flexibly positioned on the measuring table using an articulated arm.

Material

Hard-coated aluminium/stainless steel.

Supplied with

2 T-slot nuts (268600) and 2 spring fingers.

For 268900: 1 x 269200, 1 x 269100

↳ For articulated arms, see page 236.

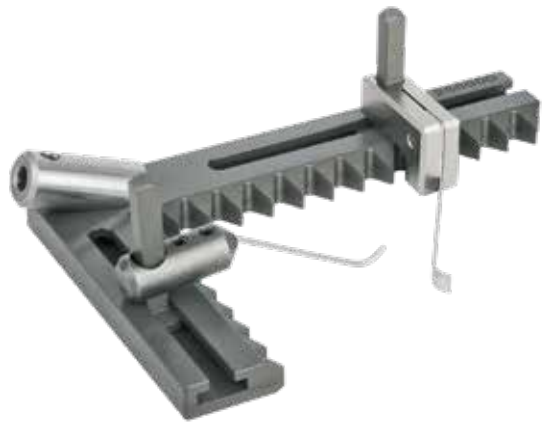

Order No.	Connection	Leg length	Leg height	Tooth pitch
268900	SWA 5	120 x 80	10	7.5

T-Nut 5
SWA 5

Application examples



Small screw jack set

Description

Adjustable base rail with height-adjustable support.

Supplied with

1x base rail (322050), 1x 15 mm extension piece (322250),
1x screw jack (322750), 1x T-slot nut (347700).

Application example



Order No.	Adjustment range	Length	Width	Height
322001	50	81	12	53

T-Nut 5

Small screw jack set with spring finger

Description

Adjustable base rail with height-adjustable support.
With spring finger for holding the workpiece.

Supplied with

1x base rail (322050), 1x 15 mm extension piece (322250),
1x screw jack (322750), 1x 30 mm adapter plate (353750), 1x 50 mm
column (269043), 1x spring finger (343700),
1x T-slot nut (347700).

Application example



Order No.	Adjustment range	Length	Width	Height
322006	50	81	12	80

T-Nut 5

Accessories

+ Base rail

Description

Adjustable base rail with slot and M 6 mounting thread.

Supplied with

Fastening screw and T-slot nut.



Order No.	Adjustment range	Total length	Width	Height
322050	50	81	12	10
322051	50	131	12	10

+ Mounting plates

Description

Mounting plates for spring finger columns with M 4 or M 6 thread. For mounting on extension pieces or directly on base rail.



Order No.	Thread for columns	Mounting hole	Overhang
353750	M 4	6	30
353850	M 6	6	50

+ Columns for spring fingers

Description

Columns for holding spring fingers.



Order No.	Column Ø	Thread	Length
269042	4	M 4	30
269043	4	M 4	50
269044	4	M 4	75
368100	6	M 6	30
368200	6	M 6	50
368300	6	M 6	75

+ Spring finger

Description

For the quick and easy holding of workpieces. For other versions, see page 130.

Order No.	Adapter Ø	T	L
269037	4	0.4	30
343700	4	0.8	30
302800	6	1	50

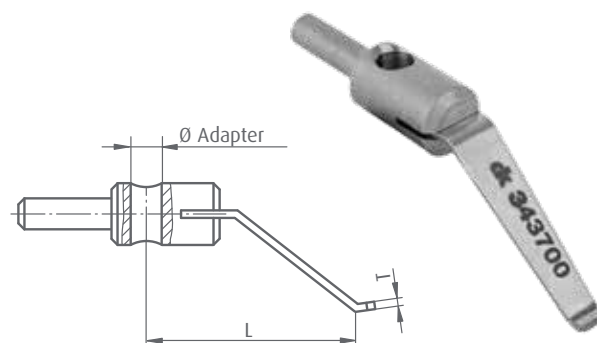

Accessories (continued)

+ Screw jacks

Description

Height-adjustable supports for supporting test parts.
With M 6 thread an adjustment range of 15 mm.



Order No.	Version	Length	Fig.
322750	With R3 mm ball end	40	1
323050	Self-aligning pad, steel, +/- 10°	35	2
323070	Ø 6 mm magnet, magnetic force 5 N	42	3

+ Hexagonal extension pieces

Description

Extension pieces with M 6 male and female thread.
Width across flats 10 mm.



Order No.	Male thread	Female thread	Length
322250	M 6	M 6	15
322350	M 6	M 6	25
322450	M 6	M 6	50

Horizontal toggle clamp for toothed rails

Description

Horizontal toggle clamp for mounting on toothed rails.

Material

Steel/hard-coated aluminium.

↳ Risers can be used to increase the clamping height, see below.



Order No.	Overhang	Clamping range	Height
336900	18-32	0-16	35

T-Nut 5

Accessories

+ Risers

Description

1 pair of risers to increase horizontal toggle clamp height.

Material

Hard-coated aluminium.



Order No.	Height
349640	12
349645	30

T-Nut 5

Application example



15 mm precision vice

Description

Miniature vice with prism jaw. With SWA 39, SWA 5 or M 4 connection. Brass or stainless steel versions available. M4 hole centre distance is 42 mm.

Supplied with

Stainless steel (270921) and plastic exchangeable jaws.



SWA 39	SWA 5	M ...
--------	-------	-------

Order No.	Version	Jaw width	Clamping width	Total height	Material	Fig.
270910	SWA 39	15	14.5	61	Brass	1
270915	SWA 39	15	14.5	61	Stainless steel	1
270900	SWA 5	15	14.5	27	Brass	2
270905	SWA 5	15	14.5	27	Stainless steel	2
270920	2 x M 4	15	14.5	15	Brass	3
270925	2 x M 4	15	14.5	15	Stainless steel	3

Accessories

+ Prism jaws

Order No.	Material	Jaw width	Supplied with	Description
270921	Stainless steel	15	1 set with 1 smooth and 1 prism jaw	With vertical and horizontal prisms



+ Stepped jaw

Order No.	Material	Jaw width	Contents	Description
270922	Stainless steel	15	1 jaw	Step height 1.5 mm Step depth 1 mm



Application examples



25 mm precision vice

Description

Miniature vice with prism jaw. With SWA 39, SWA 5 or M 4 connection. Aluminium and stainless steel versions available. M4 hole centre distance is 62.5 mm.

Supplied with

Stainless steel (270971) and plastic exchangeable jaws.

Application example



1



2



3

SWA 39

SWA 5

M ...

Order No.	Version	Jaw width	Clamping width	Total height	Material	Fig.
270960	SWA 39	25	24.5	53	Aluminium	1
270965	SWA 39	25	24.5	53	Stainless steel	1
270950	SWA 5	25	24.5	38	Aluminium	2
270955	SWA 5	25	24.5	38	Stainless steel	2
270970	2 x M 4	25	24.5	25	Aluminium	3
270975	2 x M 4	25	24.5	25	Stainless steel	3

Accessories

+ Prism jaws

Order No.	Material	Jaw width	Contents	Description
270971	Stainless steel	25	1 set with 1 smooth and 1 prism jaw	With vertical and horizontal prisms



+ Stepped jaw

Order No.	Material	Jaw width	Contents	Description
270972	Stainless steel	25	1 jaw	Stepped height 1.8 mm Step depth 1.3 mm



+ Stop

Order No.	Material	Length	Adjustment range
318250	Stainless steel/ aluminium	75	50



35 mm precision vice

Description

M 5 connection. Aluminium and stainless steel versions available. Jaws with Ø2 mm holes for clamping pins. M5 hole centre distance is 83 mm.

Supplied with

Stainless steel (270861) and plastic exchangeable jaws and 4x Ø2 pins.

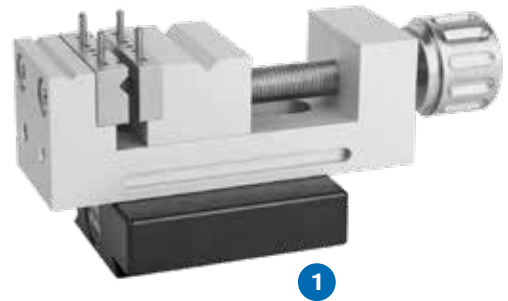

1



2

Application example



SWA 39

M ...

Order No.	Version	Jaw width	Clamping width	Total height	Material	Fig.
270850	SWA 39	35	34.5	55	Aluminium	1
270855	SWA 39	35	34.5	55	Stainless steel	1
270860	2 x M 5 / 4 x M 4	35	34.5	35	Aluminium	2
270865	2 x M 5 / 4 x M 4	35	34.5	35	Stainless steel	2

Accessories

+ Prism jaws

Order No.	Material	Jaw width	Contents	Description
270861	Stainless steel	35	1 set with 1 smooth and 1 prism jaw	With vertical and horizontal prisms



+ Stepped jaw

Order No.	Material	Jaw width	Contents	Description
270862	Stainless steel	35	1 jaw	Step height 2 mm Step depth 1.5 mm



+ Stop

Order No.	Material	Length	Adjustment range
318250	Stainless steel/ aluminium	75	50



50 mm precision centric vice

Description

Centric vice with stepped jaws and adaptation options for a range of accessory elements.
 Pin holes for raised positioning of parts for access from all sides.
 Versions with an SWA 39 quick-change adapter which can be offset through 90°.

Material

Surface-hardened steel and hard-coated aluminium.

Supplied with

4 pins, adjustable stop and operating tools.



Order No.	Version	Jaw width	Clamping width
282150	SWA 39 (removable)	50	120 mm

SWA 39

M ...

Application example

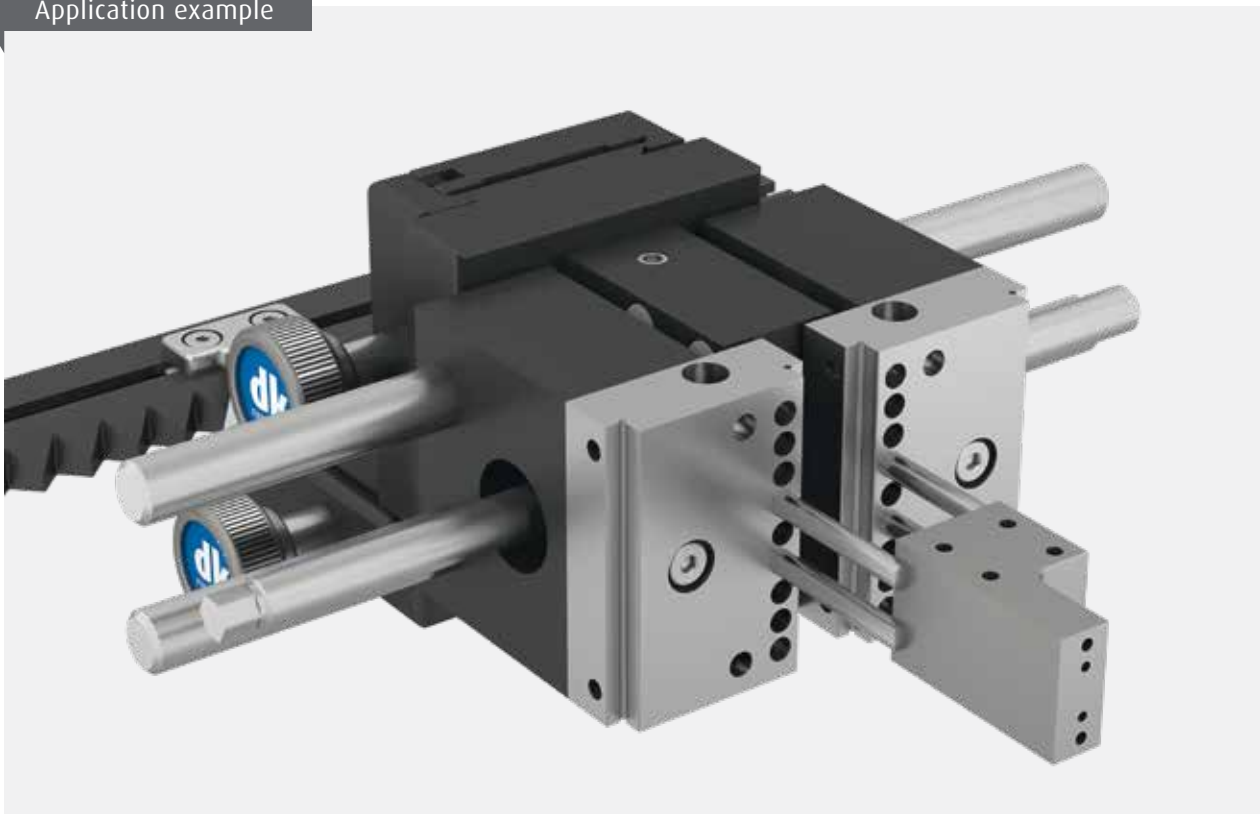

50 mm precision vice

Description

Vice with exchangeable clamping width extension guide shafts. With stepped jaws and Ø4 mm holes for clamping pins. Available with and without SWA 39 quick-change adapter and with and without accessories. The versions without quick-change adapter have 4 contact faces at right angles to each other.

Material

Surface-hardened steel.

Supplied with

Versions with accessories include an adjustable stop (318110), a set of shafts for extending the clamping width to 75 mm, 4 pins and a magnetic push-in knurled knob (282101).

✂ A quick-change adapter (397020) can be retrofitted on versions without SWA 39, see page 29.



1



2

Application example

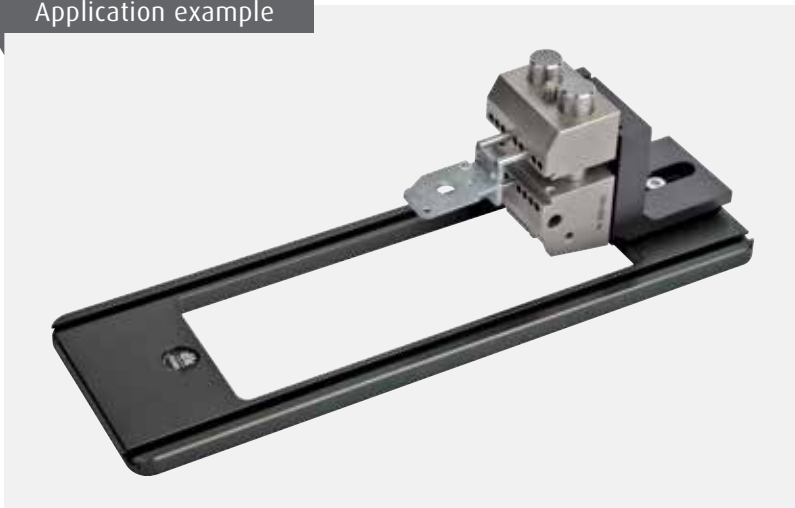

SWA 39

M ...

Order No.	Jaw width	Version	Accessories	Clamping width	Weight	Fig.
282100	50	SWA 39	yes	75*	1.05	1
282105	50	SWA 39	no	35*	0.87	
282110	50	4 contact faces	yes	75*	1.01	
282115	50	4 contact faces	no	35*	0.82	2

* Can be extended up to 150 mm with extra shaft sets.

50 mm spring-loaded vice

Description

Spring-loaded clamping system for rapid and repeatable positioning with limitable clamping force. Can be set to push or pull. For horizontal or vertical mounting on slot rails of the dk SCHIENENFIX range or on quick-change pallets.

Material

Hard-coated aluminium.

Supplied with

Screws, T-slot nuts and springs in 3 different strengths.



Order No.	Version	Jaw width	Clamping width	Clamping force
349900	For T-slot 5	50	Unlimited	Limitable

T-Nut 5

Application examples



Accessories for all 50 mm clamping elements (centric clamping vice, vice, spring-loaded vice)

+ Smooth jaws

Order No.	Material	Jaw width	Contents	Description
282400	Stainless steel	50	1 set	-



+ Prism jaws

Order No.	Material	Jaw width	Contents	Clamping diameter
282700	Stainless steel	50	1 set with 1 smooth and 1 prism jaw	Recommended from 2 mm



+ Prism jaws for end face clamping

Order No.	Material	Jaw width	Contents	Clamping diameter
306610	Stainless steel	50	1 set	15-50 mm



+ Smooth jaws for small parts

Order No.	Material	Jaw width	Contents	Description
282410	Stainless steel	50	1 jaw	For clamping small parts in the stepped jaw



Application examples



Accessories (continued)

+ Pin jaws

Order No.	Material	Jaw width	Contents	Description
282430	Stainless steel	50	1 set	For shorter clamping widths



+ Two-point contact prism jaws

Order No.	Material	Jaw width	Contents	Clamping diameter
306900	Hard-coated aluminium	5	1 prism jaw and 1 straight jaw	3–20 mm



+ Three-point contact prism jaws

Order No.	Material	Jaw width	Contents	Clamping diameter
306800	Hard-coated aluminium	5+16	1 double prism jaw and 1 straight jaw	Recommended up to 30 mm



+ Clamping pins, stepped

Order No.	Contact face	Length	Contents	Description
282300	Straight	24 x Ø 4	Set of 4	For raised parts positioning
282310	Straight	35 x Ø 4	Set of 4	
326500	120° prism	25 x Ø 4	2 prism pairs	



+ Support discs with pins

Order No.	Version	Disc size	Contents	Description
338300	Adjustable	Ø 16 x 9	Set of 4	For raised parts positioning



+ Universal stop

Order No.	Material	Supplied with
277510	Steel	2 exchangeable stop points



+ Stop for 50 mm vices (not for spring-loaded vices)

Order No.	Material	Length	Overhang	Description
318100	Steel	50	20	
318200	Steel	50	40	
318110	Steel	150	20	
318210	Steel	150	40	



+ Knurled knob for 50 mm vice (not spring-loaded vice or centric vice)

Order No.	Version
282101	Magnetic
282102	Magnetic with adjustable torque, approx. 0.1–0.3 Nm



Application examples



V-block with spring finger

Description

Small 120° V-block for holding rotationally symmetrical parts with spring fingers. Mounted on an SWA 39 quick-change adapter.

Supplied with

Bracket (343800) and spring finger (343700).



Order No.	Clamping range	Prism length	Block width	Connection	Height	Fig.
277410	Ø 2-25	10	30	SWA 39	45	2
277400	Ø 2-25	25	30	SWA 39	45	3
267900	Ø 2-25	25	30	SWA 5	25	1



V-block with magnetic prism

Description

Small 120° V-block for holding parts magnetically. With an SWA 5 quick-change mount.

Material

Hard-coated aluminium.



Application example



Order No.	Clamping range	Prism length	Block width	Mount	Height
268000	Ø 2-25	25	30	SWA 5	25



V-block holder

Description

90° support for mounting small V-blocks on T-slot. The V-blocks can be clamped in 3 different positions.

Material

Hard-coated aluminium/steel.

Application example



Order No.	Length	Width	Height
267910	20	42	52

T-Nut 5

Application example



V-block support

Description

V-block support set for holding shafts horizontally. The ends of the test pieces can be seen through the openings in the plate. The V-block supports can be mounted on the rail system at any distance from each other. The height of one of the V-blocks is adjustable. Prism width 4 mm.

Material

Aluminium/steel.

Supplied with

2 V-block supports with T-slot nuts, columns and spring fingers.



Order No.	Clamping range	Length	Width	Height
345100	Ø 2-28	75	50	40

T-Nut 5

Application example



Application examples for special V-block supports

Special V-blocks for 2 shafts on a pallet.



Special V-blocks for 3 shafts on a pallet.



Small tailstocks

Description

Pair of tailstocks, one with a fixed centre and one with a movable centre, for mounting in T-slots. The movable centre is spring-loaded and can be locked. The tailstocks can be mounted left or right. The centre height of 22 mm when mounted on a toothed rail can be increased with riser blocks.

Material

Hard-coated aluminium/steel.

Supplied with

Dead centres Ø12/60° (2x 349758), T-slot nuts and fastening screws.



Order No.	Centre height
349600	12 (22 mm on toothed rails)

T-Nut 5

Application examples



+ Dead centres

Description

60° centre for small tailstocks.

Material

Steel.

Order No.	Point	Diameter	Version	Fig.
349758	60°	0-12	-	1
349759	60°	0-12	half centre	2
349770	60°	10-22	flat point	



+ Female centres

Description

Female centres for small tailstock.

The end of the test piece can be viewed through the slit.

Material

Steel.

Order No.	Cone	Clamping range	Slit width	Fig.
349700	90°	Ø 0.5-5	0.3	1
349720	90°	Ø 2-15	1	2
349730	90°	Ø 14-30	3	



+ V centres

Description

V centre for small tailstock. The end of the test piece can be viewed through the slit.

Material

Steel.

Order No.	Prism	Diameter	Slit width
349752	90°	2-15	1



+ Riser blocks

Description

1 pair of riser blocks to increase tailstock

height.

Hard-coated aluminium.

Order No.	Height
349640	12
349645	30



Tailstocks

Description

Pair of tailstocks with one fixed and one movable centre. The movable centre is spring-loaded and can be locked. Can be mounted on all elements with T-slot 6 i.e. baseplate 262510 or Spannfix Pro slot plates. The one-part version 306020 can be combined with dividing head 261050 (page 270).

Material

Hard-coated aluminium/steel.

Supplied with

1 piece, movable centre only



Order No.	Version	Centre height	Width	Height	Fig.
306000	2 piece	50	30	75	1
306020	Single-part, only movable centre	50	30	75	

T-Nut 6

Application example

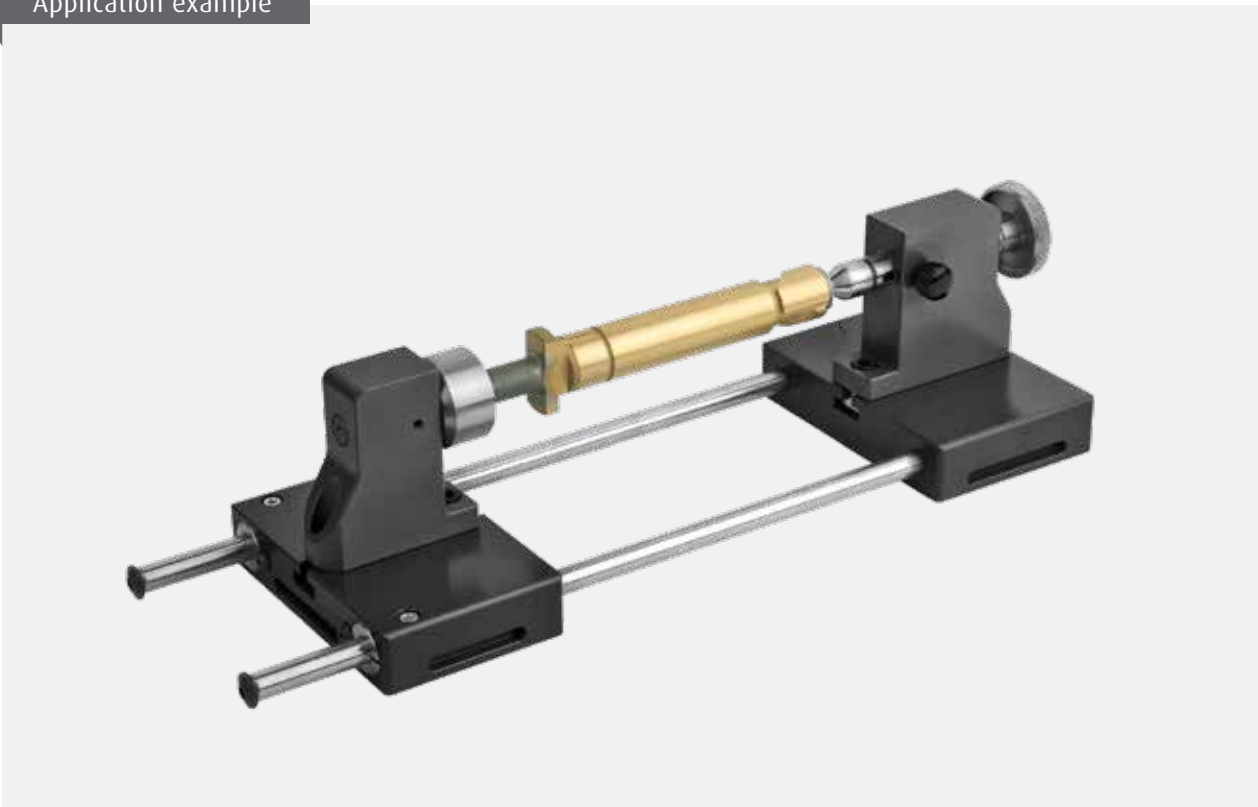

+ Adjustable baseplate

Description

Mounting plate with 6 mm T-slot for mounting tailstocks and/or dividing heads. Suitable for transmitted light measurements on projectors. Infinite adjustment on shaft guides with lock. Plate can be anchored with clamping claws.

↳ For clamping claws, see page 271.

Material

Hard-coated aluminium/steel.

Clamping length

0–210 mm.

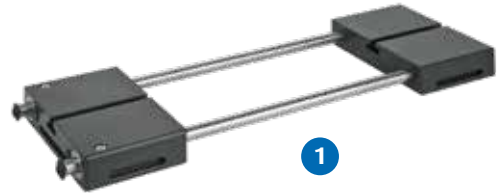

Order No.	Length	Width	Height	Fig.
262510	370	120	25	1

T-Nut 6

+ Revolving centres

Description

60° live centre for movable tailstock.

Material

Stainless steel. Point hardened.



Order No.	Point angle	Diameter
306110	60°	10
306120	60°	20

+ Dead centres

Description

A set of dead centres.

Material

Hardened steel.



Order No.	Point angle	Diameter
306100	60°	15–30

+ Female centres

Description

A set of female centres.

Material

Hardened steel.



Order No.	Cone angle	Diameter	Slit width
306320	90°	9–15	1.5
306325	90°	16–30	3

Dividing heads

Description

Dividing head with spindle ratio reduction 1:40. Precise indexing with a graduated dial and vernier scale. With ER16 collet chuck for 0.5–10 mm collets. Chucks from the range of accessories can also be mounted. Spindle locked with a knurled screw. The dividing head can be flexibly mounted using a variety of baseplates, attachment plates and mounting plates from the accessory range. Longer components can also easily be set up by using the movable tailstock (page 268) and the adjustable baseplate (page 271). The dividing head riser must be used for use with the tailstock.

Material

Aluminium/steel.

Supplied with

Collet chuck.



ER 16	ER 16
T-Nut 6	4x M4

Order No.	Version	Spindle concentricity	Vernier scale accuracy	Centre height	L/W/H	Mount	Fig.
261000	Standard	± 0.01 mm	± 10 min	24	90 / 120 / 60	4 x M 4	1
261050	Riser for use with tailstock	-	-	50	90 / 90 / 26	T-slot 6	

Application example



+ Adjustable baseplate

Description

Mounting plate with 6 mm T-slot for mounting tailstocks and/or dividing heads. Suitable for transmitted light measurements on projectors. Infinite adjustment on shaft guides with lock. Plate can be anchored with clamping claws.

Material

Hard-coated aluminium/steel.

Span

0–210 mm.

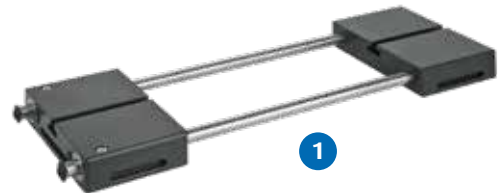

Order No.	Length	Width	Height	Fig.
262510	370	120	25	1

T-Nut 6
M ...

+ Attachment plate for clamping claws

Description

Intermediate plates for dividing heads for mounting on measuring instruments and for raising the centre height when three-jaw chucks are used.



Order No.	Length	Width	Height	Fastening
262800	60	60	30	clamping claws

4 x M4
M ...

+ Clamping claws

Description

Clamping claw set for anchoring attachment plates for dividing heads. With slot for screws up to M8.

Supplied with

2 claws with fastening screws acc. to customer specifications.



Order No.	Adjustment range	Length
263000	20	60

Accessories

+ Mounting plate

Description

Baseplate with SWA 39 quick-change mount for dividing heads. For mounting on SWA 39 quick-change clamps. For raising the centre heights when using three-jaw chucks.

Material

Hard-coated aluminium.



Order No.	Length	Width	Height
263100	60	60	20

+ Display unit

Description

Digital display unit for dividing heads. Display accuracy ± 10 s. Connection 230 V / 50 Hz.

Supplied with

Rotary encoders and connectors for standard dividing heads.



Order No.	Length	Width	Height
261200	235	220	85

Application example



+ Precision three-jaw chuck

Description

Version with ER16 for mounting on dividing heads. Intermediate plates for raising the dividing head may be required with larger chucks or workpieces.

Material

Steel



Order No.	OD	Mount	Concentricity	Information
261350	50	ER 16	± 0.04	On request
261351	65	ER 16	± 0.04	
261352	34	ER 16	± 0.04	On request

ER 16

+ Collets

Description

For the dividing head collet chuck.

Material

Steel



↪ A complete set of collets which includes all diameters can be ordered under part number 263450. See table below.

Order No.	Clamping Ø
263400	0.5-1
263401	1-2
263402	2-3
263403	3-4
263404	4-5
263405	5-6
263406	6-7
263407	7-8
263408	8-9
263409	9-10
263450	Complete set of collets 0.5-10 mm (art. No. 263400 to 263409)

ER 16

Precision mini chuck

Description

Precision mini chuck with inside jaws. For internal and external clamping of rotationally symmetrical parts. Mounted on SWA 39 or SWA 5 quick-change adapters.

Material

Hard-coated aluminium/steel.



Order No.	Connection	For OD	For ID	Height	Diameter	Fig.
283700	SWA 39	0.2-3	3-5	59	24	
283900	SWA 39	0.5-5	5-9	79	32	1
283600	SWA 5	0.2-3	3-5	60	24	2
283800	SWA 5	0.5-5	5-9	80	7932	



Application example



34 mm precision three-jaw chuck

Description

Hand-operated three-jaw chuck with tool-free reversible jaws for internal and external clamping of rotationally symmetrical workpieces.

Chuck precision without further attachments:

Radial runout < 0.03 mm

Axial run-out < 0.01 mm

Repeat accuracy < 0.01 mm

With SWA 39 quick-change adapter. Also available with SWA 5 quick-change adapter which can be held on the shaft OD (14 mm).

Material

Completely stainless steel.

More information available in the SWA 39 section from page 16.



Application examples

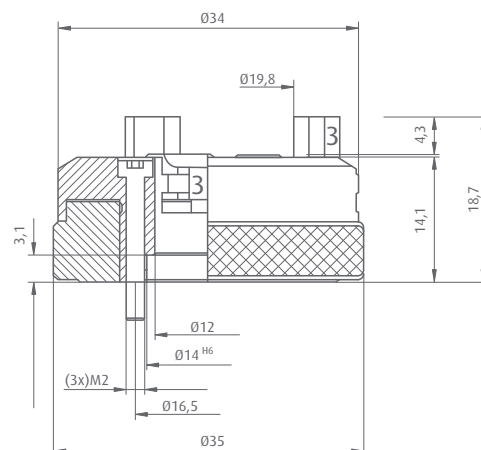
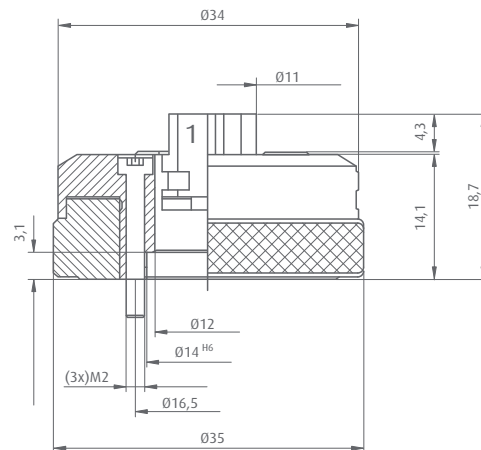
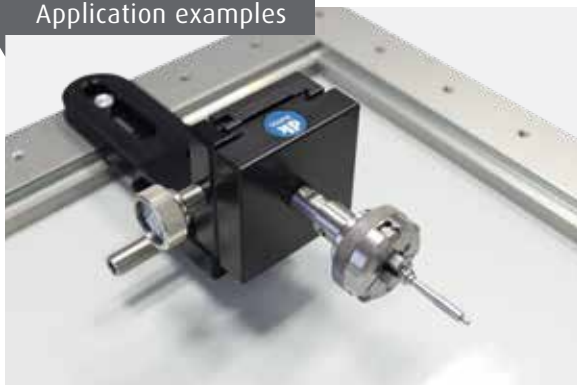

Order No.	Connection	Size	Height	
329000	SWA 39	34	72	SWA 39 SWA 5
329010	SWA 5	34	38.5	

50 mm precision three-jaw chuck

Description

Hand-operated three-jaw chuck with tool-free reversible jaws for internal and external clamping of rotationally symmetrical workpieces. With pin hole and 2 sets of pins in a range of heights for raised fixing of parts for access from all sides. Pin holes $\varnothing 2$, depth 7 mm.

Precision of jaw chucks without additional extensions:
 Radial runout < 0.03 mm
 Axial run-out < 0.01 mm
 Repeat accuracy < 0.01 mm
 With SWA 39 quick-change adapter. Also available with mounting holes or MK 2 supports.

Material

Hard-coated steel and aluminium.

Supplied with

With control apparatus and 2 sets of 3 12 mm and 18 mm pins.

More information available in the SWA 39 section from page 62 onwards.



2



3

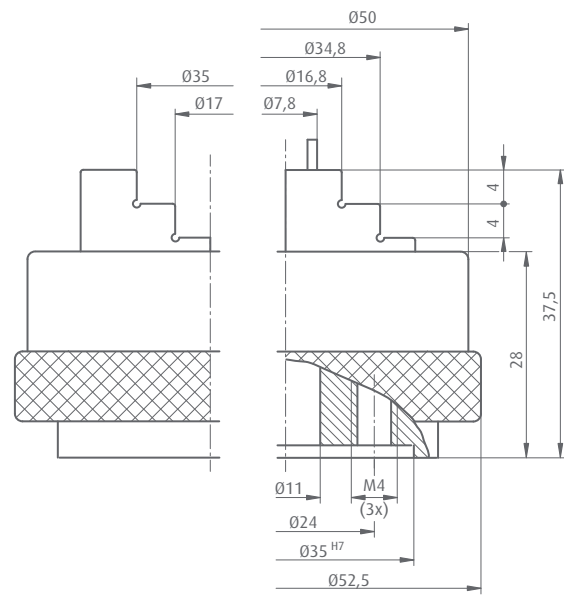

Order No.	Connection	Size	Height	Fig.
329705	SWA 39	50	58	1
329720	3 x M 4	50	38	2
329725	MK 2*	50	46.5	3



* Other supports available on request.

Small-parts clamp with stepped jaw

Description

Small-parts clamp with stepped jaw one side. For clamping small parts. Clamps with spring force. With an SWA 5 quick-change mount.

Material

Steel.

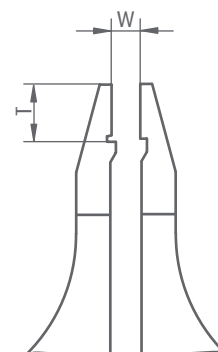

Order No.	Jaw width	Clamping width (W)	Jaw depth (T)	Length
265700	1.5	0-1.6	2.1	82
266100	3	0-1.6	2.1	82
266600	5	0-1.6	2.1	82

SWA 5

Application example



Small-parts clamp, smooth

Description

Small-parts clamp with smooth jaw. For clamping small parts. Clamps with spring force. With an SWA 5 quick-change mount.

Material

Steel.

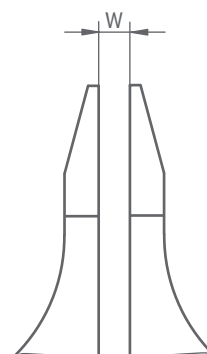

Order No.	Jaw width	Clamping width (W)	Length
265800	1.5	0-1.6	82
266000	3	0-1.6	82
266500	5	0-1.6	82

SWA 5

Application example



Small-parts clamp with prism jaw

Description

Small-parts clamp with prism jaw. For holding rotationally symmetrical parts. Clamps with spring force. With an SWA 5 quick-change mount.

Material

Steel.

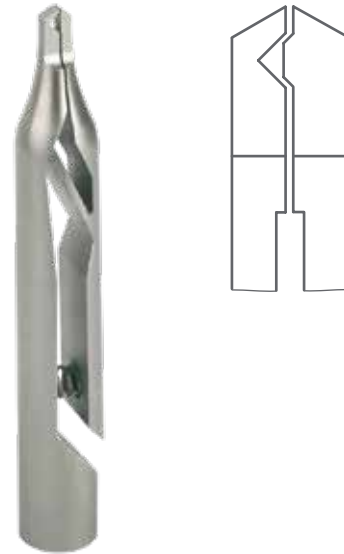

Order No.	Jaw width	Clamping diameter	Length
265900	1.5	0.3-1.5	82
266200	2	0.5-2.0	82
266700	2.5	1.5-3.0	82

SWA 5

Small-parts clamp with screw tightener

Description

Small-parts clamps with different jaw types. Clamps with a screw. With an SWA 5 quick-change mount.

Material

Steel.

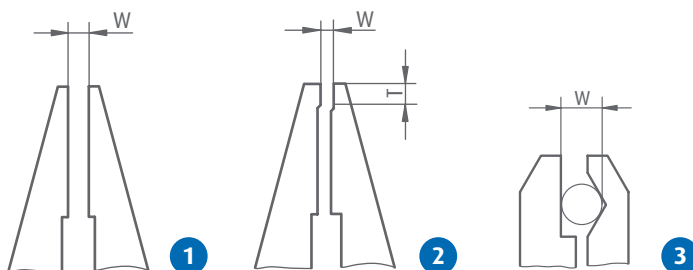

Order No.	Jaw type	Jaw width	Clamping width (W)	Jaw depth	Length	Fig.
267500	Smooth	4.8	0-5	-	82	1
267600	Stepped	4.8	0-5	1.8	82	2
267610	Prism	4.8	3.2-6	-	82	3

SWA 5

Stop for small-parts clamps

Description

Adjustable stop for small-parts clamps. Fits on all spring operated small-parts clamps.

Material

Steel/stainless steel.



Application example



Order No.	Length	Width	Height
266800	55	17	27

U-clamp

Description

Micro U-clamp for holding small parts with a screw. Connection with an SWA 5 quick-change mount.

Material

Stainless steel.



Application example

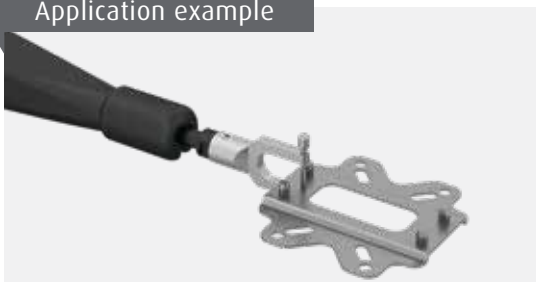

Order No.	Jaw thickness	Clamping width	Clamping depth
266900	4	0-12	15

SWA 5

Magnet

Description

Permanent magnet with an SWA 5 quick-change mount.

Material

Stainless steel.



Order No.	Magnet Ø	Magnetic force (N)	Length
267810	16	95	26



Application example



Parallel clamps

Description

Parallel clamps with a clamping range of 0–25 mm. The jaws without a guide pin can be rotated. Those with a guide pin are held parallel. The jaw faces are available in different versions: Flat, with a prism for holding round workpieces or convex for holding highly sensitive workpieces. The parallel clamps are mounted on an SWA 5 quick-change adapter.

Material

Stainless steel/steel/aluminium.

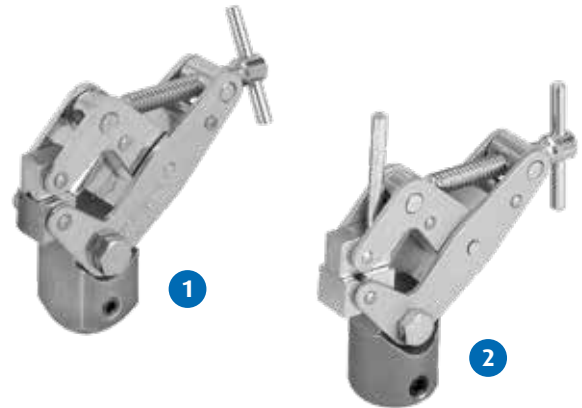

Order No.	Lower jaws	Upper jaws	Version	Fig.
278800	3 flat, 1 long prism	3 flat, 1 long prism	Both jaws rotatable	1
278600	2 flat, 1 long prism, 1 convex	2 flat, 1 long prism, 1 convex	Both jaws rotatable	1
279200	Cross prism	Flat	With guide pin	2

SWA 5

Application example



Multispannfix

Description

Universal clamping device for simple, quick fixation of rotationally symmetrical and cubic parts. Rest frame height 5 mm.

Material

Hard-coated aluminium/safety glass/acrylic glass rest frame.

Supplied with

Spring-loaded thrust clamp and cone tip (269055).



Order No.	Size	Length	Width	Clamping range	Fig.
269050	1	124	100	40	1

Application example



+ Spring thrust clamp

Description

Spring thrust clamp with cone tip and adapter for T-slots.

Material

Stainless steel/brass.



Order No.	Length	Application
269057	115	For size 1

T-Nut 5

+ Cone tip

Description

Thrust tip for spring thrust clamp for high and precise clamping force transfer.

Material

Stainless steel.



Order No.	Version
269055	Cone tip

+ Movable clamping tip

Description

Movable clamping tip for a secure hold even by imperfectly aligned spring thrust clamps.

Material

Stainless steel.



Order No.	Version
269056	Movable clamping tip

NADELFIX 2.5

Description

NADELFIX for fix-variable self-moulding from products. Ideal for clamping moulded parts. With SWA 39 quick-change mount. Function and advantages are described on page 76.

Supplied with

Clamping fixture comprising rail (396120), column (269043) and spring finger (269038). Fasteners included

↳ For other Nadelfix clamping elements and accessories, see the SWA 39 section on pages 76 to 79.

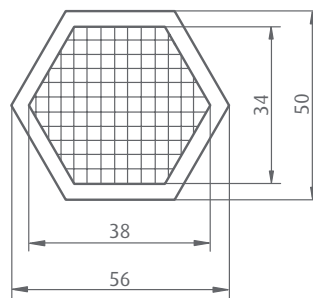

Order No.	Pin Ø	Support area	Total height	Spring travel
396030	2.5	38 x 34	55	Max. 10

SWA 39

Application example



Inspection vice

Description

Due to a perpendicularity and parallelism precision of 0.005 mm, all 4 sides can be used. Horizontally and vertically ground prism jaws. Vice and fixed jaw machined from a single piece. By using the attachment sets the vices can also be used in the SWA 39 system.

Material

Alloyed tool steel, hardened to 60 HRC and finely ground.



Order No.	Total length		Width	Height	Clamping width	Weight	Perpendicularity / parallelism
	Open	Closed					
270720	116	91	20	22	24.5	0.175 kg	5 µm
270730	SWA 39 adapter set for 20 mm vice (270720)						
270740	175	140	35	35	34.5	0.775 kg	5 µm
270750	SWA 39 adapter set for 35 mm vice (270740)						
270760	235	175	50	50	59.5	1.970 kg	5 µm
270770	SWA 39 adapter set for 50 mm vice (270760)						

SWA 39

Four-way hexagon key

Description

Practical and compact cross design with 3 key sizes per tool. Covers all hexagon socket sizes used in the Spannfix and Schienenfix ranges.

Material

Steel.

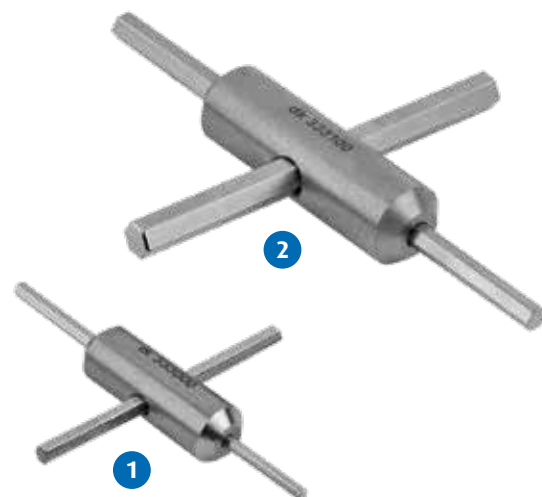

Order No.	Size	Fig.
333000	2 / 2.5 / 3	1
333100	4 / 5 / 6	2

Schienenfix basic sets

Description

Clamping set for optical measurement tasks. For constructing a simple frame that can be clamped to the measuring equipment table using claw clamps. Includes 4 spring fingers for quick and easy holding of test parts. There are sets with 5 mm or 10 mm tooth pitch each in three set versions for different measuring table sizes available.

Ordering information

All sets are supplied with M4, M5 and M6 screws. If the thread on your equipment is different, please let us know when placing your order.

Toothed rails for other table sizes available on request.

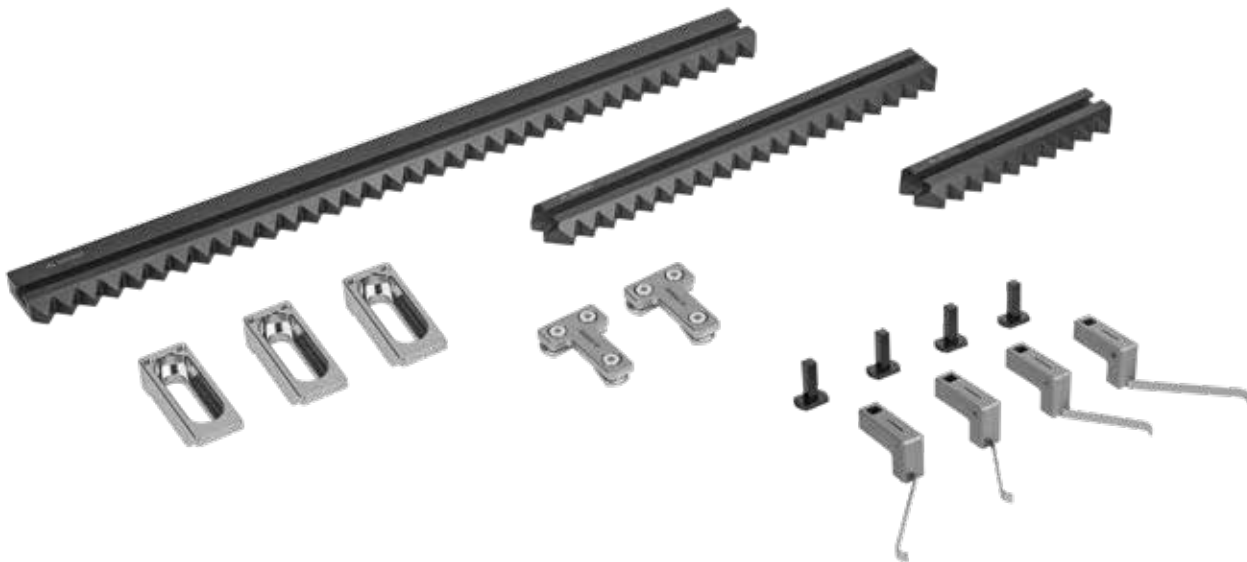

Set versions

Order No.	Description	Tooth pitch	Measuring window
269915	Basic set, model "1"	5	200 x 100
269925	Basic set, model "2"	5	300 x 200
269935	Basic set, model "3"	5	400 x 200
269910	Basic set, model "4"	10	200 x 100
269920	Basic set, model "5"	10	300 x 200
269930	Basic set, model "6"	10	400 x 200

Set contents – toothed rails with fine toothing

Order No.	Description	Set "1"	Set "2"	Set "3"
345020	Base rail, 250 mm / T 5	1	-	-
345220	Base rail, 350 mm / T 5	-	1	-
345420	Base rail, 450 mm / T 5	-	-	1
347220	Connecting rail, 100 mm / T 5	2	1	1
346020	Connecting rail, 200 mm / T 5	-	1	1
348000	Rail connecting pieces	2	2	2
262924...26	45 mm clamping claws, M 4-M 6	3	3	3
349100	34 mm spring finger, left	1	1	1
349200	34 mm spring finger, right	1	1	1
349300	50 mm spring finger, left	1	1	1
349400	50 mm spring finger, right	1	1	1
268500	Mounts for spring finger, 20 mm	4	4	4
-	Screws M 4 / M 5 / M 6 (3 of each)	1	1	1

Set contents – toothed rails with standard toothing

Order No.	Description	Set "4"	Set "5"	Set "6"
345000	Base rail, 250 mm / T 10	1	-	-
345200	Base rail, 350 mm / T 10	-	1	-
345400	Base rail, 450 mm / T 10	-	-	1
347200	Connecting rail, 100 mm / T 10	2	1	1
346000	Connecting rail, 200 mm / T 10	-	1	1
348000	Rail connecting pieces	2	2	2
262924...26	45 mm clamping claws, M 4-M 6	3	3	3
349100	34 mm spring finger, left	1	1	1
349200	34 mm spring finger, right	1	1	1
349300	50 mm spring finger, left	1	1	1
349400	50 mm spring finger, right	1	1	1
268500	Mounts for spring finger, 20 mm	4	4	4
-	Screws M 4 / M 5 / M 6 (3 of each)	1	1	1



Schienenfix expansion sets for turned parts

Description

Expansion sets with different support and clamping elements for rotationally symmetrical parts. These modules are for fastening to Schienenfix toothed rails.

"Standard" set

"Small" set



Set versions

Order No.	Description
269950	"Standard" Schienenfix expansion set for turned parts
269951	"Small" Schienenfix expansion set for turned parts

Set contents

Order No.	Description	"Standard" set	"Small" set
267900	V-block with spring finger	1	1
267910	V-block holder	1	1
273320	Quick-action clamp	1	-
283300	Quick-action clamp 90° angle element	1	-
329705	50 mm precision three-jaw chuck	1	-
345100	V-support (1 pair) with spring finger	1	-
349600	Tailstock	1	1

Schienenfix expansion sets for milled and sheet parts

Description

Expansion sets with different clamping elements for milled and sheet parts. The modules can be attached to Schienenfix toothed rails.

"Standard" set

"Small" set



Set versions

Order No.	Description
269960	"Standard" Schienenfix expansion set for milled and sheet parts
269961	"Small" Schienenfix expansion set for milled and sheet parts

Set contents

Order No.	Description	"Standard" set	"Small" set
266100	Small-parts clamp with stepped jaw	1	-
269050	Multispannfix	1	-
273320	Quick-action clamp	1	1
283300	Quick-action clamp 90° angle element	1	1
282100	50 mm precision vice with accessories	1	1
282300	Pins for raised parts clamping	1	1
314900	Rotary swivel mount	1	-

3-point support set

Description

3-point support for plate, bent and moulded parts. Flexible adjustment of supports in X, Y and Z axis. Quick and easy workpiece holding using spring fingers. The adjustable base rails can be anchored anywhere along the T-slot of the toothed rails. The supports are height-adjustable. Height differences can be accommodated using extension pieces.



Set versions

Order No.	Description
269965	3-point support set

Set contents

Order No.	Description	"Standard" set
322006	Screw jack with spring finger	3
322350	25 mm extension pieces	3
322450	50 mm extension pieces	3
323050	Steel self-aligning pads	2
269042	30 mm columns for spring fingers	3

Application example



Pallets with clamping elements

Description

Sets with pallets and differently mounted clamping elements. Available in pallet sizes 305 mm x 100 mm (345801) and 195 mm x 100 (345821) mm.



1



4

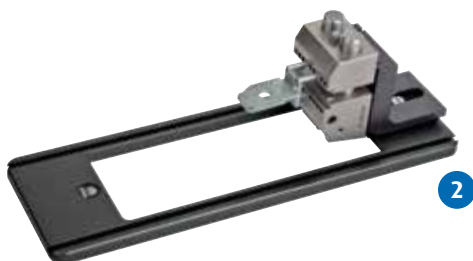

2



5



3

Application example



The clamped workpieces shown are application examples and are not supplied.

Set versions

Order No.	Description	Basic pallet	Supplied with	Fig.
345802	Pallet with 1 tailstock	305 x 100 x 10	345801, 349600	1
345822	Pallet with 1 tailstock	195 x 100 x 10	345821, 349600	
345804	Pallet with precision vice	305 x 100 x 10	345801, 283300, 282100	2
345824	Pallet with precision vice	195 x 100 x 10	345821, 283300, 282100	
345805	Pallet with mini chuck and rotary/swivel mount	305 x 100 x 10	345801, 314900, 283600	3
345825	Pallet with mini chuck and rotary/swivel mount	195 x 100 x 10	345821, 314900, 283600	
345806	Pallet with small V-block	305 x 100 x 10	345801, 267910, 267900	4
345826	Pallet with small V-block	195 x 100 x 10	345821, 267910, 267900	
345807	Pallet with V-block support	305 x 100 x 10	345801, 345100	5
345827	Pallet with V-block support	195 x 100 x 10	345821, 345100	

Universal clamping sets

Description

The clamping elements can be placed directly onto the measuring table or, if the SWA 39 quick-change adapter is fitted, positioned using the swivel unit.



Set versions

Order No.	Description	Fig.
269850	"Universal with swivel unit" clamping set incl. case	1
269855	"Universal" clamping set incl. case	

Set contents

Order No.	Description	"Universal with swivel unit" set	"Universal" set
270920	15 mm precision vice	1	1
270860	35 mm precision vice	1	1
282115	50 mm precision vice	1	1
282300	Set of 4 stepped pins for vice	1	1
267900	V-block with spring finger	1	1
270560	Swivel unit with attachment plate and quick-action clamp	1	
397020	SWA 39 adapter plate for 35 mm and 50 mm vices	1	
314100	SWA 39 adapter plate for 15 mm vice or V-block	1	
329705	50 mm precision three-jaw chuck with SWA 39 quick-change adapter	1	



The clamping elements contained in the set.



The clamping elements can be placed directly onto the measuring table or they can be positioned at any angle using the swivel unit.

Clamping component sets

Description

For optical measuring instruments and microscopes. For clamping e.g. plastic, punched or turned parts. The basis is a high-quality articulated arm on which clamping elements such as a mini chuck, spring finger or parallel clamp can be mounted.

Ordering information

When ordering, let us know the thread or T-slot size on your measuring equipment.



Set versions

Order No.	Description	Fig.
269805	"Standard model II" clamping component set with storage box	1
269815	"Small model II" clamping component set with storage box	

Set contents

Order No.	Description	"Standard model II" set	"Small model II" set
296800	Articulated arm, type SU	1	1
268900	Rest angle with spring clamp including: 120 x 80 mm rest angle 2 columns for spring fingers (268600) left-hand spring fingers for horizontal clamping (269200) 35 mm spring finger for vertical clamping (269100)	1	1
268200	Right-hand spring finger for horizontal clamping	1	
268100	50 mm spring finger for vertical clamping	1	
283600	Precision mini chuck	1	
267900	V-block with spring finger	1	1
266100	Small-parts clamp with stepped jaw	1	
278800	Parallel clamp	1	1
269300	Spring finger with SWA 5	1	
269600	Rotary unit	1	
269700	Satellite mount, horizontal	1	
270900	15 mm precision vice	1	1
333000	Four-way hexagon key	1	1
Customer specifications	Adapter or T-slot nuts (see ordering information)	1	1

Application examples



MICROFIX

***Clamping solutions
for micro parts from
0.3 mm to 10 mm***

- » Gentle fixation with adjustable clamping forces
- » For rotationally symmetrical and cuboid test parts

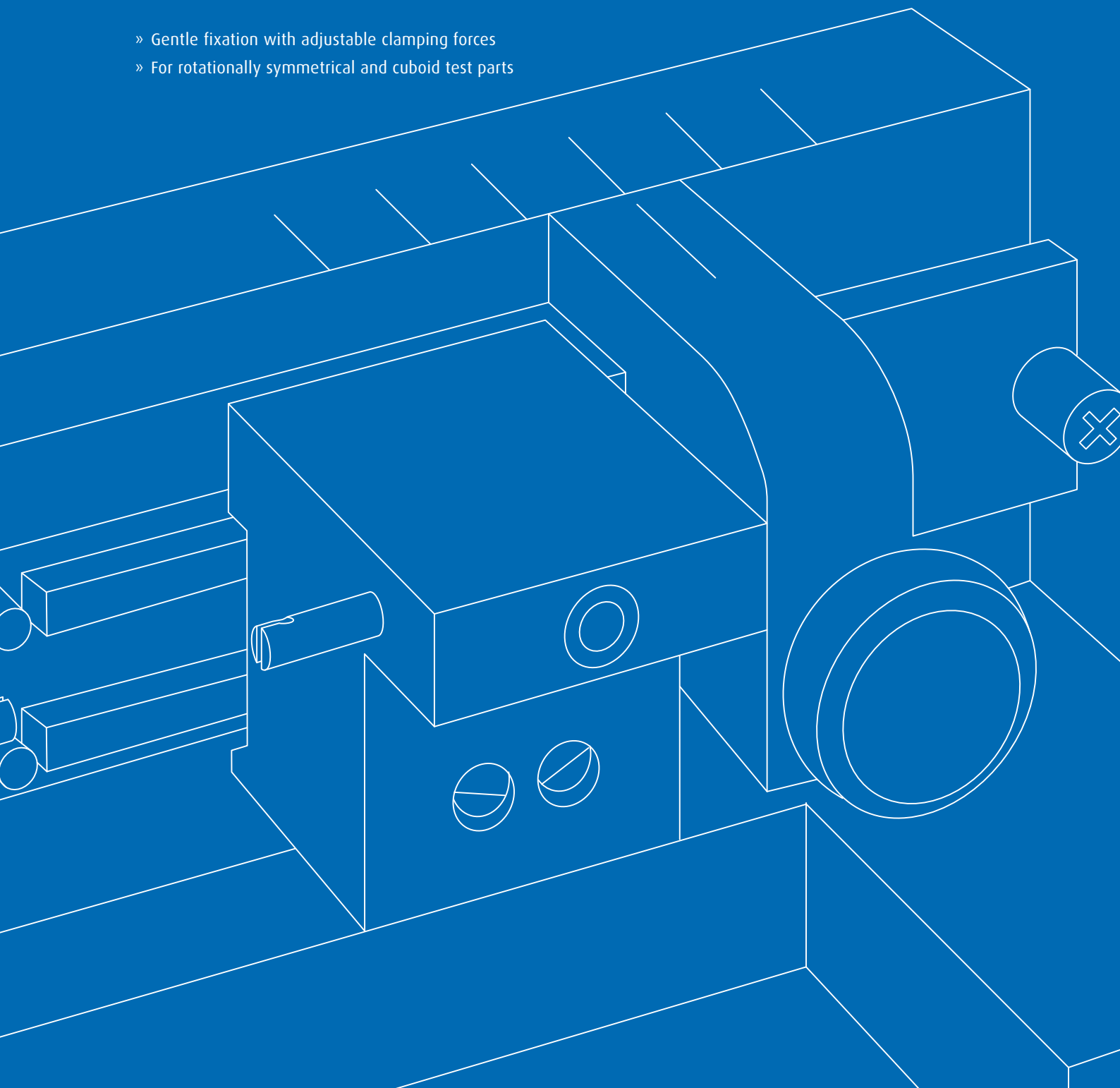

Clamping elements



Micro fixture for cubic parts

Page 300



Micro fixture "Prisma"

Page 300



Micro tailstock

Page 301

Micro fixture for cubic parts

Description

For holding cubic parts with constant and adjustable clamping force. The clamping force is generated by a slanting plane and can be adapted to specific requirements by adding ball weights. To ensure that test parts are held securely even by low clamping forces, the fixed jaw can be adapted using adjustable stops. The movable part of the fixture is also fitted with a pendulum jaw.



Application example



Order No.	Clamping range	Length	Width	Height	Jaw width	Supplied with
398030	< 0.3-10	85	60	30	6	10 steel balls

Micro fixture "Prisma"

Description

For holding rotationally symmetrical test parts with a diameter of 0.5 mm to 6 mm or up to 10 mm with accessories. The holding force is adjustable and exerted by several micro springs.

Accessories

Interchangeable plates (398035) enabling the clamping range for rotationally symmetrical test parts to be increased to 5 mm to 10 mm.



Application example



Order No.	Clamping range	Length	Width	Height	Jaw width
398032	∅ 0.5-6	85	60	32	10
398035	∅ 0.5-10	1 set of interchangeable plates			

Micro tailstock

Description

For holding rotationally symmetrical test parts. The test pieces can be measured along their whole length as they are mounted between female centres with measurement slits. With adjustable holding force. The clamping range can be freely adjusted up to a maximum of 25 mm.

Supplied with

Female centres (see diagram).

Accessories

60° male centres (398060).



Application example

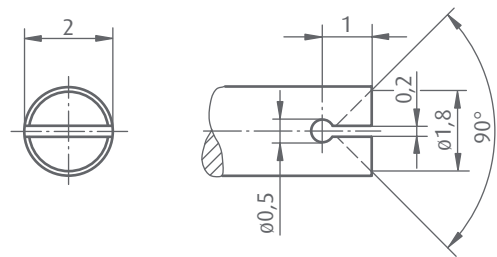

Order No.	Centre height	Length	Width	Height	Version	Fig.
398052	37	90	60	40	With mounting plate	1
398060			Ø2 x 60° male centres (1 pair)			

Application example



SPEZIALFIX

Customer-specific clamping fixtures

- » We develop, design and manufacture special clamping devices according to your specifications
- » Testing and measuring fixtures, analysis stations, inspection and test gauges
- » Simple or complex multi-clamping systems with mechanical, pneumatic, electromechanical or combined fixturing, clamping and handling components
- » Economical solutions using components from the dk standard ranges
- » Measuring tables for mobile measuring equipment for direct mounting of test parts using standard and special fixing elements
- » Improved overall equipment effectiveness thanks to automation using linear and robotic technology

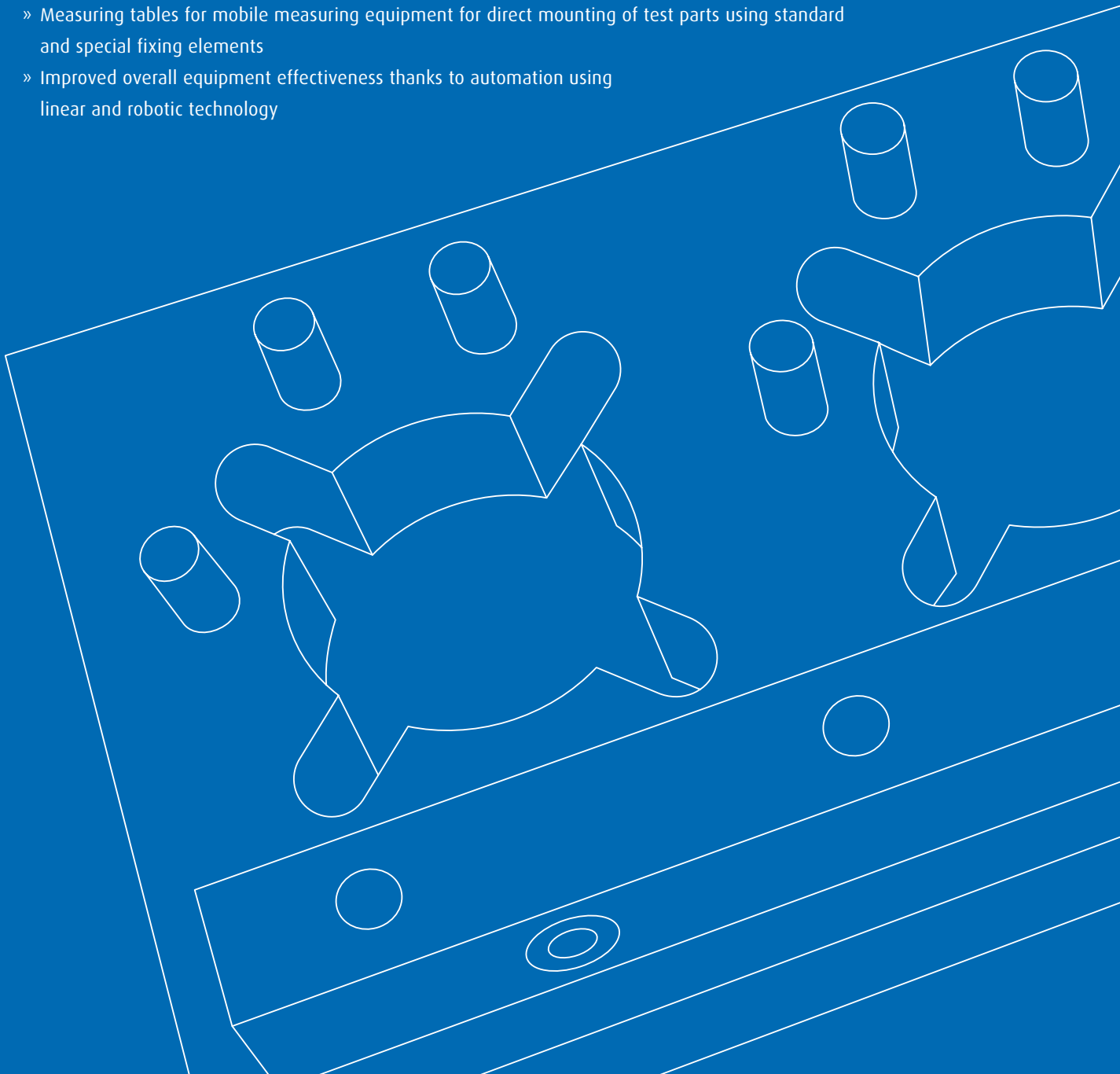

Special solutions



Clamping and measuring equipment connection for batteries

Page 304



Multi-clamping for milled, turned and punched parts

Page 305



Multi-clamping for turned parts

Page 305



Multi-clamping for round deep drawn parts

Page 306



Vacuum multi-clamping device

Page 306



Multi-clamping for optical measuring

Page 307



Multi-clamping for optical and tactile measuring

Page 307



Precision module system Q-Line

Page 308



Motor-driven tailstock configuration

Page 308



Measuring tables for mobile measuring equipment for direct mounting of fixturing systems

Page 309



Automation: set-up and loading systems with linear and robotic technology

Page 310

Clamping and measuring equipment connection for batteries

- Designed for one-hand operation
- Colour coding to prevent incorrect operation: red anodised jaw at positive pole
- Spring-loaded fixture for secure electrical contact
- Stepped supports that can be adjusted without tools for different battery sizes for central positioning on the poles
- Stroke and clamping force can be preset without tools
- Covered and protected cable guide in the guide columns
- Completely new design in line with customer requirements

Application example



Multi-clamping for milled, turned and punched parts

- Multiple fixturing system for any number of parts as a combination of standard modules on special plates or frames
- Fixed and movable jaws separately positionable for a wide clamping range
- Jaws can be mounted vertically or horizontally
- Interchangeable jaws from the module range or as a custom-made product for part-specific fixation
- Force strength, force direction and travel of the movable jaw are freely adjustable, limitable and reproducible
- For optical or tactile measuring machines



Application example



Multi-clamping for turned parts

- 6x tailstocks for turned parts
- Held using spring-loaded, stepped female centres from the Schienenfix range
- Mounted on a quick-change pallet for setups outside of the machine
- For optical measuring machines

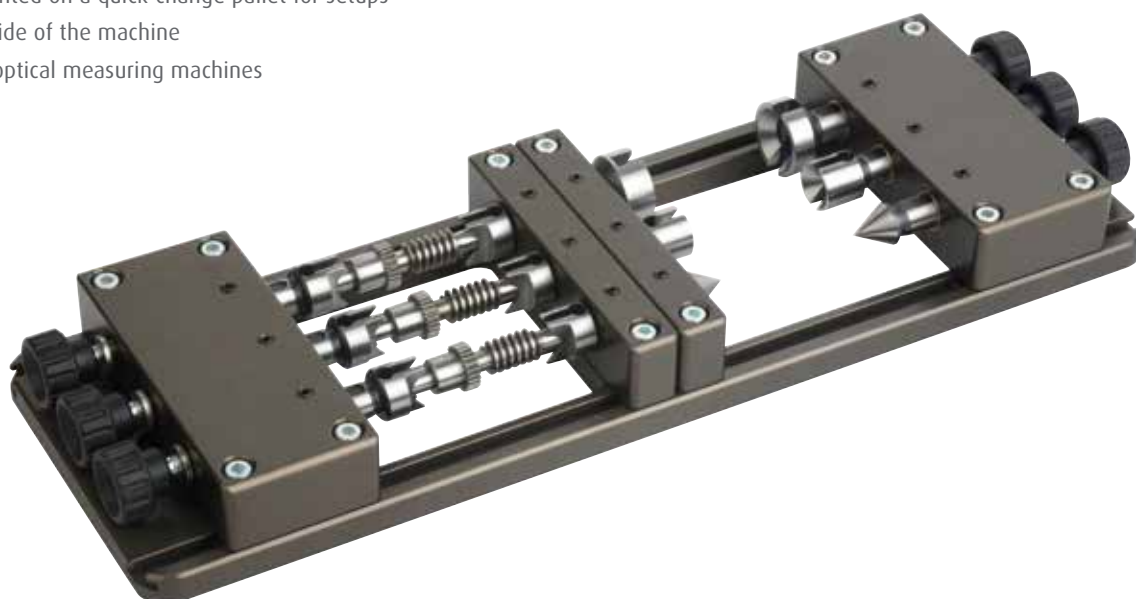

Multi-clamping for round deep drawn parts

- 4x pallet construction; easy handling through low weight and grips
- Positioning in Z axis using exchangeable pins
- Centric fixturing using hand-operated three-jaw chuck from the standard range
- Mounted on a quick-change pallet for setups outside of the machine
- For tactile measuring machines



Vacuum multi-clamping device

- 12x clamping for disc-shaped ceramic test pieces
- Each clamping point can be actuated individually
- Maximum equipment configuration for given measuring volume
- For tactile measuring machines



Multi-clamping for optical measuring

- 20x clamping fixture for small plastic parts for medical technology
- With insertion aid
- Individual clamping
- For optical measuring instruments

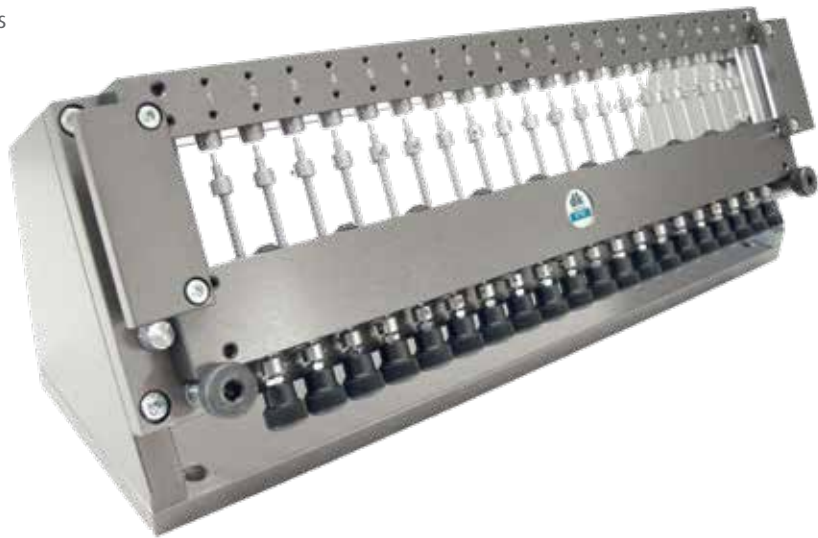

Multi-clamping for optical and tactile measuring

- 4x clamping fixture for sheet metal parts
- Individual clamping
- For multi-sensorial measuring equipment



Precision module system Q-Line

- Vice and spring-loaded vice system for special and multi-clamping using standard parts
- High precision even for the smallest workpieces
- Jaws positioned for easy implementation of even highly part-specific geometries
- System rails for positioning elements in precise increments
- Fully compatible with the SWA 39 product range

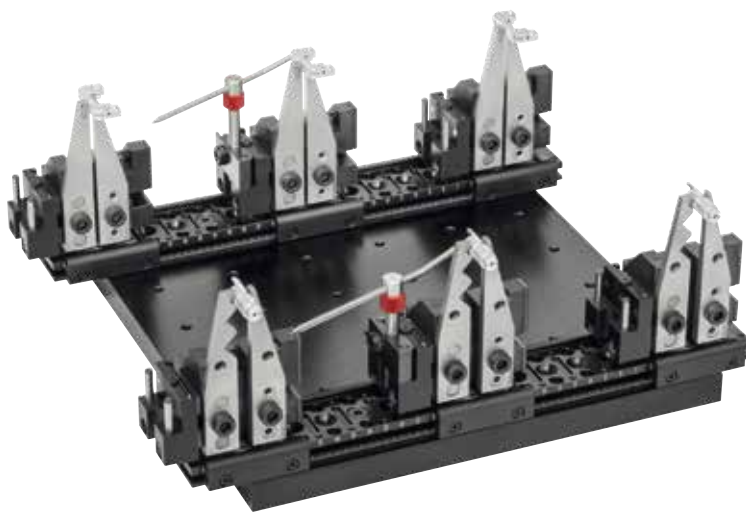

Motor-driven tailstock configuration

- Tailstock with movable centre for holding
- For testing the entire circumference of parts or in controllable rotated positions
- For dimension and surface inspection

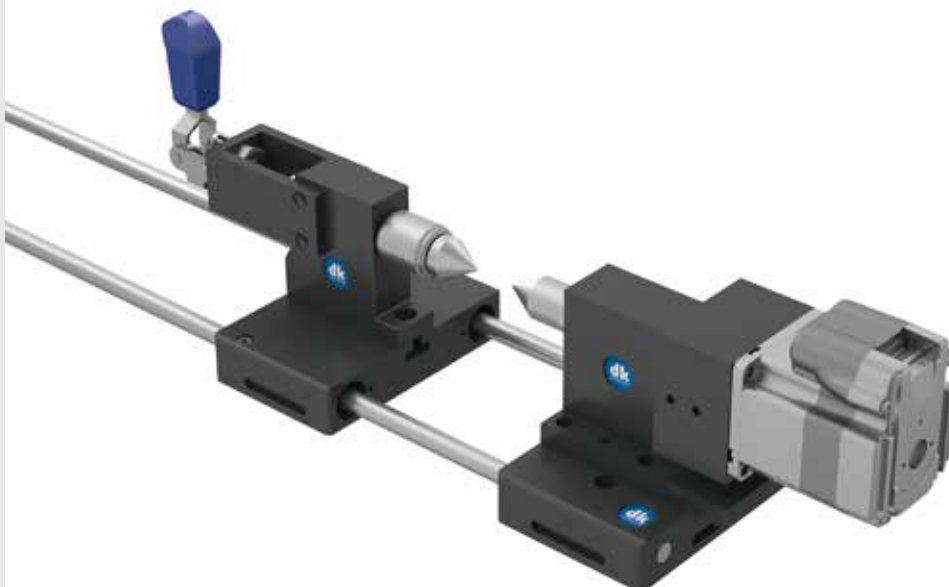

Tables for mobile equipment for direct mounting of fixturing systems

- For CMM, white light, laser and combi systems
- System plates for direct mounting of clamping systems:
 - > For example, drilling plate for use with the *SPANNFIX ECO* range
 - > Customer-specific grid holes with or without threaded bushings
- Customer, part and process-specific bench sizes and frame design
- Material: hard-coated aluminium plate on a stable aluminium profile frame
- Frame with fixed height, fixed and variable adjustment or freely adjustable
- Levelling feet to accommodate uneven floors
- Can be moved with a forklift and includes positioning aids for the forks
- Also available with freely positionable adapter plates for measuring equipment
- Standard height of 900 mm
- Standard depth of 800
- Standard widths of 800, 1200, 1600 and 2000 mm
- Available in all manner of part and process-specific versions
- Many versions of below table draws or hinged door cabinets optionally available



Automation: set-up and loading systems with linear and robotic technology

- Process-specific systems for moving setup processes outside of the measuring machine
- Direct automatic equipping of measuring machines with individual test parts or with mounting plates already equipped with several test parts
- Significantly reduced downtime on costly measuring equipment and improved overall equipment effectiveness
- Possible applications:
 - Simple manual systems for situation-dependent positioning of palletised test parts
 - Efficient and compact linear systems made from standard industry modules
 - Flexible, highly functional and non-application-specific robot systems
- Pallet station in front of the actual loading system to ensure efficient processing with high-throughput; modular assembly, manual or automatic transport, measuring equipment-specific dimensions
- Integrated parts clamping fixtures from the dk standard ranges or as a custom-made product

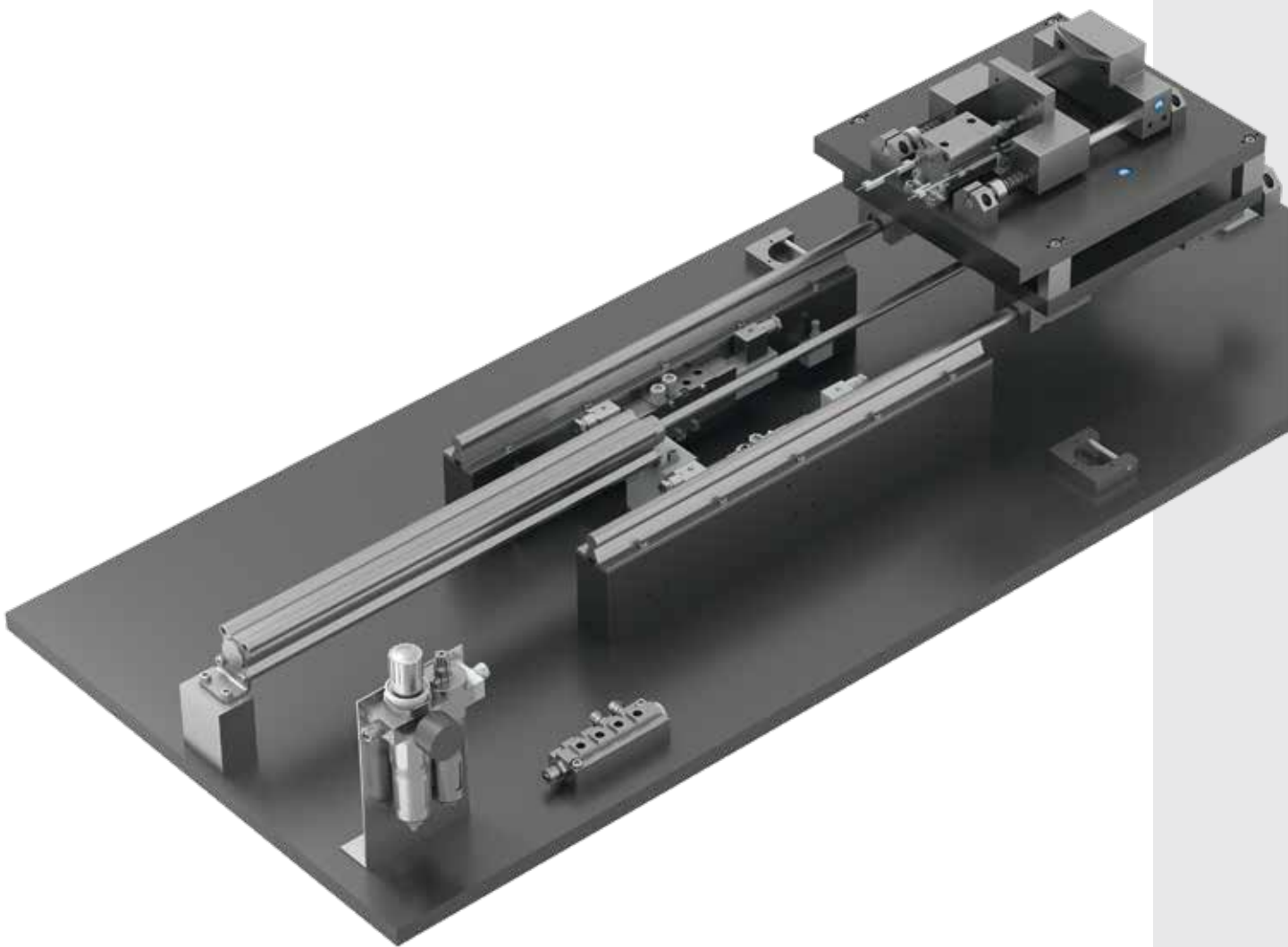

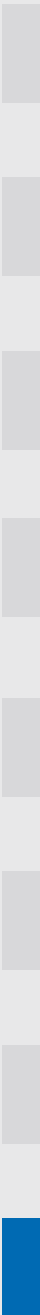
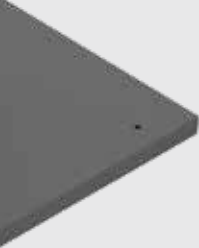

Part number index

dk 353750

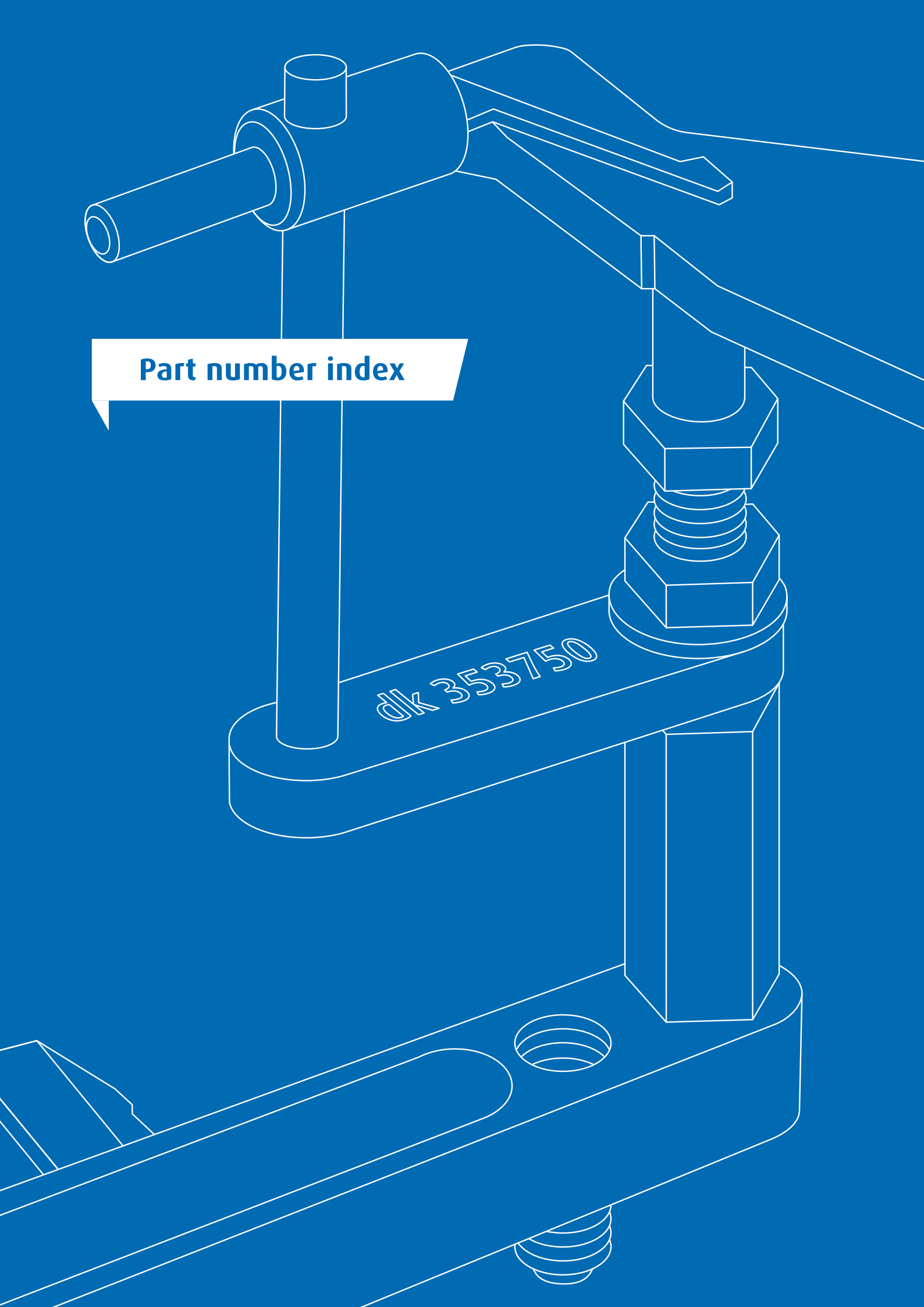

Part numbers

Order No.	Page
250000	
251400	25
251500	25
253500	112, 163, 207
260000	
261000	270
261050	270
261200	272
261350	273
261351	273
261352	273
262510	143, 268, 269, 271
262800	271
262910	231
262914	231
262915	231
262916	231
262918	231
262920	231
262924	231, 289
262925	231, 289
262926	231, 289
262928	231
262940	231
262944	231
262945	231
262946	231
262948	231
262950	231
262954	231
262955	231
262956	231
262958	231

Order No.	Page
263000	271
263100	272
263400	61, 273
263401	61, 273
263402	61, 273
263403	61, 273
263404	61, 273
263405	61, 273
263406	61, 273
263407	61, 273
263408	61, 273
263409	61, 273
263450	61, 273
263710	233
264000	230
264100	230
264600	230
264700	230
264800	230
265000	230
265300	230
265310	230
265500	230
265700	278
265800	279
265900	280
266000	279
266100	278, 291, 297
266200	280
266500	279
266600	278
266700	280
266800	281
266900	281
267355	74

Order No.	Page
267360	74
267365	74
267370	74
267500	280
267600	280
267810	282
267900	87, 262, 290, 293, 295, 297
267910	263, 290, 293
267915	245
268000	262
268100	243, 297
268200	297
268300	133, 175, 245
268500	243, 289
268600	243, 247, 297
268700	243
268900	247, 297
269037	79, 130, 172, 244, 249
269038	76, 79, 130, 172, 286
269039	79, 130, 172
269042	79, 127, 131, 169, 173, 244, 249, 292
269043	76, 79, 127, 131, 169, 173, 244, 245, 248, 249, 286
269044	79, 127, 131, 169, 173, 244, 249
269050	284, 291
269055	284, 285
269056	285
269057	285
269100	243, 247, 297
269300	133, 175, 245, 297
269500	126, 168
269600	237, 297

Part numbers

Order No.	Page	Order No.	Page	Order No.	Page
269700	236, 297	270865	41, 255	273330	235
269805	296	270900	38, 252, 297	273600	30
269815	296	270905	38, 252	273700	30
269850	294	270910	38, 252	273800	30
269855	294	270915	38, 252	273900	30
269910	288	270920	38, 252, 295	274700	24
269915	288	270921	38, 252	274710	24
269920	288	270922	38, 252	274720	24
269925	288	270925	38, 252	275000	126, 168, 185, 187
269930	288	270950	40, 254	275010	126, 168
269935	288	270955	40, 254	275030	126, 168
269950	290	270960	40, 254	275100	126, 168
269951	290	270965	40, 254	275110	126, 168
269960	291	270970	40, 254	275200	126, 168
269961	291	270971	40, 254	275300	126, 168
269965	292	270972	40, 252	275600	80, 95, 97
270000		270975	40, 254	275700	81
270200	26, 92	271200	42	275800	82
270500	36, 97	271500	42	275810	82
270560	27, 295	271900	42	275900	82
270570	36	272700	88, 96	275910	82
270650	37	272810	88	276000	80
270700	42	272850	89, 91, 141	276100	81
270720	287	272900	89, 91, 141	276200	80
270730	287	272902	89, 91, 141	276210	80
270740	287	272920	89, 96	276300	81
270750	287	272930	89	276310	81
270760	287	272940	91, 141	276800	83
270770	287	273000	28	276805	83
270850	41, 255	273006	28	277300	82
270855	41, 255	273008	28	277305	82
270860	41, 111, 162, 255, 295	273010	28	277315	82
270861	41, 255	273012	28	277320	82
270862	41, 255	273300	23	277325	82
		273320	235, 290, 291	277400	87, 262

Order No.	Page
277410	87, 262
277500	84
277510	43, 46, 50, 54, 57, 59, 260
278000	85
278200	85
278210	85
278300	86
278310	86
278400	136, 151, 153, 178, 185, 187
278500	136, 178
278600	136, 178, 283
278800	136, 178, 283, 297
279200	137, 179, 283
279210	137, 179
279300	137, 179
279600	137, 151, 153, 179
279610	136, 178
279620	136, 178
280000	
280500	104, 150
280800	104, 150, 152
280900	104
281200	104
281406	107, 150, 152, 193
281408	107, 150, 152, 193
281410	107, 150, 152, 193
281412	107, 150, 152, 193
281430	160
281432	160
281436	160, 187
281438	160
281600	106
281700	106
281730	106

Order No.	Page
281735	106
281750	106
281760	106
282100	48, 95, 96, 257, 291, 293
282101	48, 50, 257, 260
282102	50, 260
282105	48, 257
282110	48, 111, 162, 257
282115	48, 257, 295
282150	44, 256
282200	49
282300	43, 46, 50, 96, 260, 291, 295
282310	43, 46, 50, 260
282400	45, 49, 259
282410	45, 49, 259
282430	46, 50, 260
282700	45, 49, 259
283220	18, 63, 70, 94, 96
283225	63, 70
283230	71
283250	67, 69, 95, 96
283255	71, 94, 96
283260	73
283300	33, 235, 290, 291, 293
283320	33
283450	31
283460	31
283480	61
283600	60, 274, 293, 297
283700	60, 274
283800	60, 274
283900	60, 274
285130	184
285140	184

Order No.	Page
285155	185
285160	186
285170	186
285204	22, 182
285205	22, 182
285206	22, 94, 95, 97, 111, 162, 182, 187
285208	22, 94, 95, 97, 182
285210	22, 94, 95, 97, 182
285212	22, 94, 95, 97, 182
285300	22, 94, 95, 97, 148, 152
285810	138, 180, 185, 187
286600	118, 150, 151, 153
286700	118, 150, 151, 152
286800	118, 153
287000	120
287100	120, 153
287200	121, 150, 151, 153
287210	121
287500	122, 150, 153, 167
288605	116, 152
288650	116
288805	116, 150, 151, 152
288905	116, 150, 151, 152
289005	116
289105	116
290000	
290600	109
290700	109, 150, 153
292700	145
292800	145
293600	145
293800	145
294000	93

Order No.	Page
318110	42, 43, 46, 48, 50, 52, 54, 56, 56, 57, 58, 59, 88, 257, 260
318200	43, 46, 50, 54, 57, 59, 260
318210	43, 46, 54, 50, 57, 59, 260
318250	40, 41, 254, 255
319300	119, 150, 153, 203, 220
319400	119, 150, 203, 219
319500	119, 153, 203, 220
320000	
320500	125, 152
320600	125
322001	248
322005	115, 153, 166, 184, 185, 187, 210
322006	248, 292
322010	110, 115, 151, 161, 166, 206, 210
322050	248, 249
322051	249
322200	112, 115, 150, 151, 153, 163, 166, 185, 187, 207, 210
322250	204, 248, 250
322300	112, 150, 151, 153, 163, 184, 185, 187, 207
322350	204, 250, 292
322400	112, 150, 151, 153, 163, 185, 187, 207
322450	204, 250, 292
322500	150
322600	113, 150, 153, 164, 184, 187, 208
322700	113, 115, 150, 151, 164, 166, 208, 210
322750	204, 248, 250

Order No.	Page
323000	113, 150, 153, 164, 185, 187, 208
323050	204, 250, 292
323060	204
323070	204, 250
323400	114, 151, 165, 185, 187, 209
323500	114, 151, 165, 185, 187, 209
324100	124, 152
324600	124
325000	159
325100	105, 151, 159
326400	108, 110, 111, 151, 153
326500	43, 46, 50, 260
326600	54, 57, 59, 94
326610	54, 57
326800	108
328500	105, 159
329000	63, 64, 275
329010	63, 64, 275
329020	64
329030	64
329400	114, 165, 209
329500	114, 151, 153, 165, 185, 187, 209
329700	63, 68, 95, 96, 277
329705	63, 66, 276, 290, 295
329710	63, 68, 277
329715	63, 68, 277
329720	63, 66, 276
329725	63, 66, 276
329730	67, 69
330000	
330310	63, 72
330311	73

Order No.	Page
330312	73
330315	63, 72
330506	23
330508	23
330510	23
330512	23
330606	23
330608	23
330610	23
330612	23
330800	24
333000	147, 181, 287, 297
333100	147, 181, 287
334900	136, 178
336300	134, 176, 215
336400	134, 176, 187, 215
336900	251
338300	43, 46, 50, 260
340000	
340530	94
340540	94
340615	95
340700	96
343700	79, 87, 130, 172, 244, 245, 248, 249, 262
343710	130, 172, 244
344900	228
344920	228
345000	228, 289
345020	228, 289
345100	264, 290, 293
345200	228, 289
345220	228, 289
345400	228, 289

Part numbers

Order No.	Page	Order No.	Page	Order No.	Page
345420	228, 289	348200	230	356400	202, 219, 220
345600	228	349100	242, 289	356600	202, 219, 220
345620	228	349150	242	356700	202
345801	240, 293	349200	242, 289	357000	198
345802	293	349250	242	357100	198
345804	293	349300	242, 289	357500	200
345805	293	349400	242, 289	357700	202, 220
345806	293	349600	266, 290, 293	357800	200
345807	293	349640	251, 267	359400	196, 220
345815	240	349645	251, 267	359500	196
345821	240, 293	349700	267	359600	196
345822	293	349720	267	359700	196, 220
345824	293	349730	267	359800	196
345825	293	349752	267	359900	196
345826	293	349758	266, 267		
345827	293	349759	267	360000	
345830	240	349770	267	360100	195
346000	229, 289	349800	232	360300	195
346020	229, 289	349900	258	360400	195
346200	229			360500	195
346220	229	350000		360600	195
346400	229	352110	117	360900	195
346420	229	352150	117	361600	195
346600	229	352200	117	361700	192
346620	229	352300	117	362000	192, 219
347000	229	352400	117	362100	192, 219
347020	229	352500	117	362900	217
347200	229, 289	352550	117	363300	193
347220	229, 289	353700	115, 132, 166, 174, 210, 214	363600	199
347400	229	353750	248, 249	364000	194, 219, 220
347420	229	353800	132, 174, 187, 214	364100	194, 219, 220
347500	246	353850	249	364200	194
347510	246	356000	206	364300	194, 219, 220
347700	230, 244, 248	356200	206	364400	194, 220
348000	230, 289	356300	206	364500	194, 219, 220

Order No.	Page	Order No.	Page	Order No.	Page
364600	194, 220	368710	127, 131, 151, 169, 173, 213	396120	76, 79, 286
364700	194, 219, 220	368720	127, 131, 169, 173, 213	397012	111, 162
364800	194	368800	127, 131, 169, 173, 213	397013	111, 162
366000	198	368810	127, 131, 151, 169, 173, 213	397014	111, 162
366300	216	368820	127, 131, 169, 173, 213	397015	111, 162
366400	200, 219, 220	368900	127, 131, 169, 173, 213	397016	111, 162
366500	199, 219, 220	368910	127, 131, 151, 169, 173, 213	397017	111, 162
366600	211, 219, 220	368920	127, 131, 169, 173, 213	397020	29, 48, 257, 295
366700	211, 219, 220	369000	126, 168, 206	397030	29
367000	201, 221	369100	206, 221	397040	29
367100	201, 221	369200	206, 221	398030	300
367200	201, 221	369800	219, 221	398032	302
367500	198	369900	221	398035	302
367600	198	369915	218	398052	301
367700	198	369920	218	398060	301
367800	198	369930	220	399700	152
368100	79, 127, 131, 169, 173, 213, 249	370000		399710	150
368120	127, 131, 169, 173, 213	376800	138, 180	399720	150
368200	79, 127, 131, 169, 173, 213, 219, 249	390000		399730	151
368220	127, 131, 169, 173, 213	390010	82		
368300	77, 78, 79, 89, 115, 127, 131, 166, 169, 173, 210, 213, 219, 249	390200	80		
368400	79, 127, 131, 169, 173, 213, 220	390300	81		
368500	79, 91, 127, 131, 141, 169, 173, 184, 187, 213	391500	81		
368505	127, 131, 169, 173, 185, 187, 213	391600	80		
368600	127, 131, 169, 173, 213	395020	158		
368610	127, 131, 169, 173, 213	395030	158, 184, 187		
368620	127, 131, 169, 173, 213	395040	158, 184, 187		
368700	127, 131, 169, 173, 213	396000	77		
		396005	77		
		396010	77		
		396020	78		
		396030	76, 286		
		396110	77, 79		

Looking for a specific product? We'd be happy to help.

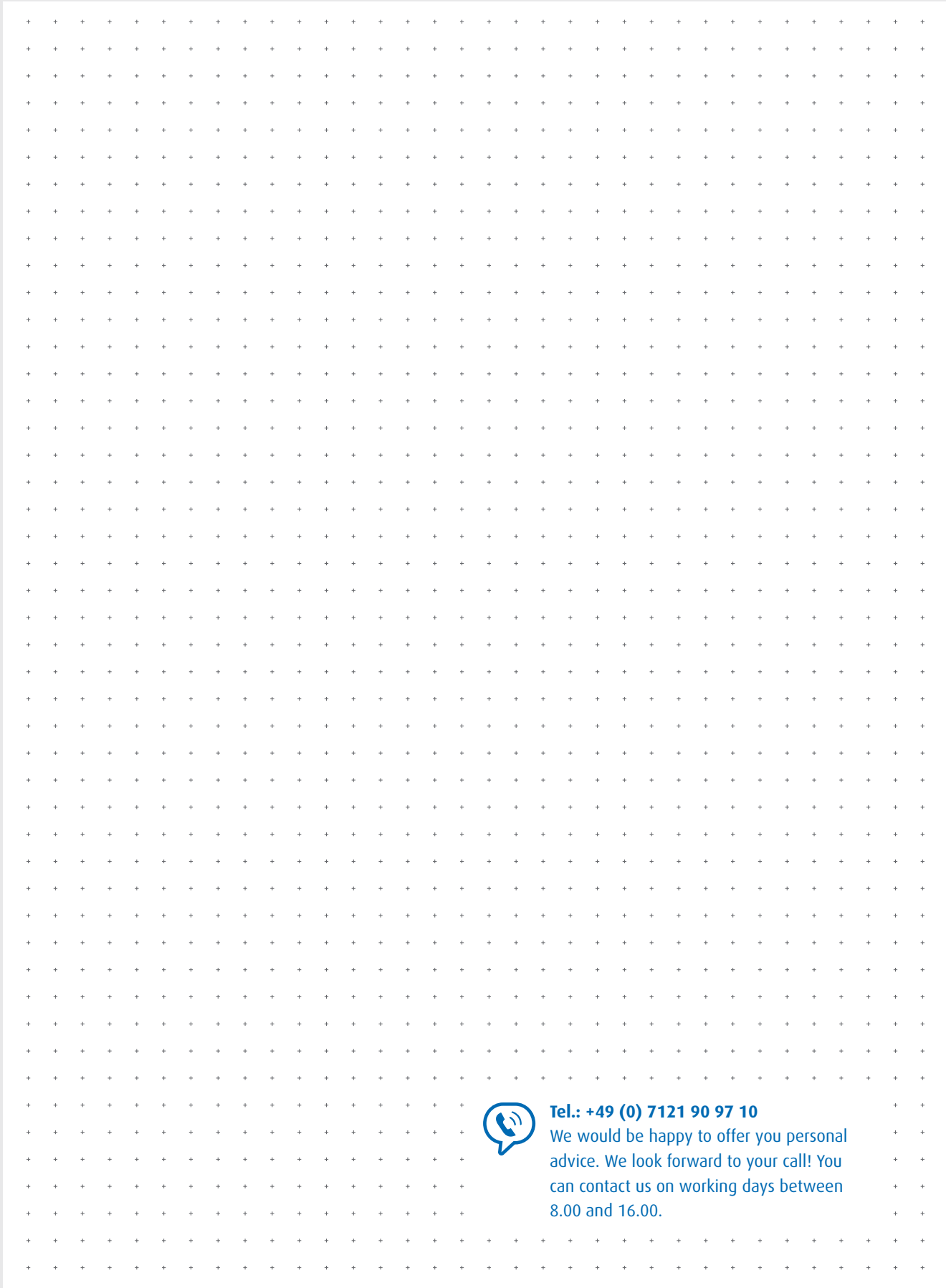

Tel.: +49 (0) 7121 90 97 10

We would be happy to offer you personal advice. We look forward to your call! You can contact us on working days between 8.00 and 16.00.

Imprint

Publisher

dk FIXIERSYSTEME GmbH & Co. KG
Ferdinand-Lassalle-Straße 35
72770 Reutlingen, Germany
info@dk-fixiersysteme.de
www.dk-fixiersysteme.de

Status

04/2019

Graphic design and typesetting

KLAREKÖPFE GmbH – Advertising agency, Stuttgart
info@klarekoepfe.de · www.klarekoepfe.de

Information

With the release of this catalogue, all previous publications become invalid. Dimensions and other data correspond to the current level of technology. We reserve the right to make technical changes. We accept no liability for any printing errors. Any reprinting or reproduction – in whole or in part – is permitted only with our prior consent.



The digital version of our catalogue is available here:

www.dk-fixiersysteme.de



Do you have any questions about our products?

We would be happy to offer you personal advice. We look forward to your call! You can contact us on working days between 8.00 and 16.00 on +49 (0) 7121 90 97 10.

*Find more information
about our clamping systems
for measurement
technology online.*



Explore our website:

www.dk-fixiersysteme.de



Subscribe to our YouTube channel:

[www.youtube.com \(dkfixiersysteme\)](http://www.youtube.com/dkfixiersysteme)



Follow us on Facebook:

www.facebook.com/dkfixiersysteme



**FAST
REASSEMBLY
LIFELONG**

The entire world of fixturing, clamping and positioning.

SWA39



SPANNFIX PRO

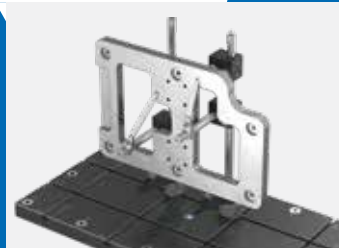

SPANNFIX ECO



QUADERFIX



SCHIENENFIX



MICROFIX



SPEZIALFIX



The basic principle of all dk fixturing systems:
"Fast Reassembly Lifelong"

Our modular fixtures can effortlessly be disassembled and precisely reassembled at any time. The compatibility of dk's fixturing systems guarantees maximum value for customers.

dk
FIXIERSYSTEME

modular. simple. better.



Global Source
EQUIP TO INNOVATE