

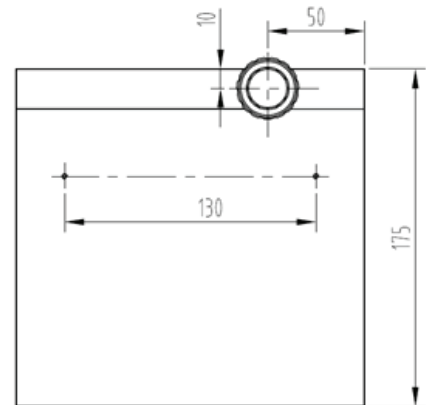

Global Source  
EQUIP TO INNOVATE

# XY STAGE

AI 100-010

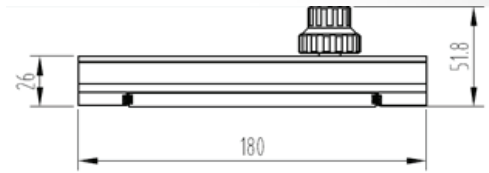
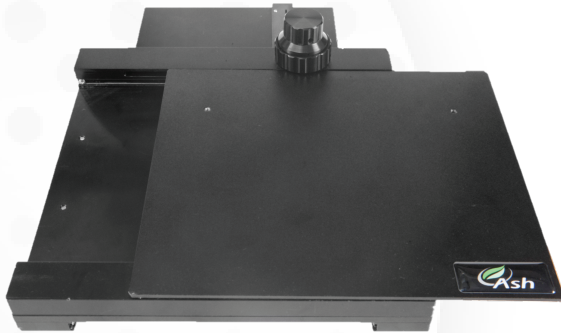

## KEY FEATURES

- XY Control with Dual Knob
- Clamps for securing slides or other objects

## SPECIFICATIONS

DIMENSIONS (L X W X H MM)	17.5 x 18 x 5.1
MOVING RANGE	X: 100, Y: 86
WEIGHT	2.2 KG